

LEGEND

- ASPHALT PAVEMENT
- LANDSCAPE AREA
- CONCRETE SIDEWALK
- BUILDING AREA
- AMENDED SOILS AREA

PROJECT SUMMARY

AREA
 AREA: 55.56± ACRES
 APN: 499-010-074-000, (LOT 1) (25.88 AC)
 APN: 499-010-075-000, (LOT 2) (29.68 AC)

SPECIFIC PLAN
 SIERRA VISTA SPECIFIC PLAN
 PARCELS KT-41A AND KT-41B

LAND USE DESIGNATION
 COMMUNITY COMMERCIAL (CC)

ZONING
 GENERAL COMMERCIAL (GC)

PROPOSED USES
 COMMUNITY CARE FACILITY,
 LONG-TERM CARE FACILITY,
 AND MEDICAL SERVICES

DEVELOPER
 ERICKSON SENIOR LIVING, LLC
 701 MAIDEN CHOICE LANE
 BALTIMORE, MD 21228
 ATTN: STEVEN MONTGOMERY
 STEVEN.MONTGOMERY@ERICKSONSENIORLIVING.COM

PROPERTY OWNER
 KV SIERRA VISTA, LLC
 7801 FOLSOM BOULEVARD
 SACRAMENTO, CA 95826

ENGINEER
 KIMLEY-HORN AND ASSOCIATES
 555 CAPITOL MALL, SUITE 300
 SACRAMENTO, CA 95814
 ATTN: FAREED PITTALWALA
 FAREED.PITTALWALA@KIMLEY-HORN.COM

ARCHITECT
 LANTZ-BOGGIO
 5650 DTC PARKWAY, SUITE 200
 ENGLEWOOD, CO 80111
 ATTN: DAVID FIK
 DFK@LANTZ-BOGGIO.COM

BUILDING SUMMARY

BUILDING	STORIES	SQUARE FEET	PARKING
RB 1.1	5	211,010	
CB 1.0	1	14,720	
RB 1.2	5	214,325	
RB 1.3	6	184,075	
RB 1.4	6	151,900	
RB 1.5	6	198,409	
Skilled Nursing Facility (SNF)	1	27,262	
RB 2.1	5	185,526	
CB 2.0	1	19,077	
RB 2.2	6	194,440	
RB 2.3	6	277,240	
RB 2.4	5	125,240	
RB 2.5	6	171,612	
Assisted Living (AL)	4	155,568	
PARK & RIDE			50
SITE TOTALS:		2,130,404	1872

DEVELOPMENT SUMMARY

APN: 499-010-074-000, 499-010-075-000
 SITE AREA: ±55.56 ACRES (±2,420,193 SF)

EXISTING	ACRES	PERCENT
PERVIOUS AREA:	55.56 AC	100%
IMPERVIOUS SURFACE (PAVEMENTS)	0 AC	0%
IMPERVIOUS SURFACE (BUILDINGS)	0 AC	0%
TOTAL AREA:	55.56 AC	100%

PROPOSED	ACRES	PERCENT
PERVIOUS AREA (LANDSCAPE)	21.39 AC	38%
IMPERVIOUS SURFACE (PAVEMENTS)	20.21 AC	36%
IMPERVIOUS SURFACE (BUILDINGS)	13.97 AC	25%
TOTAL AREA:	55.56 AC	100%

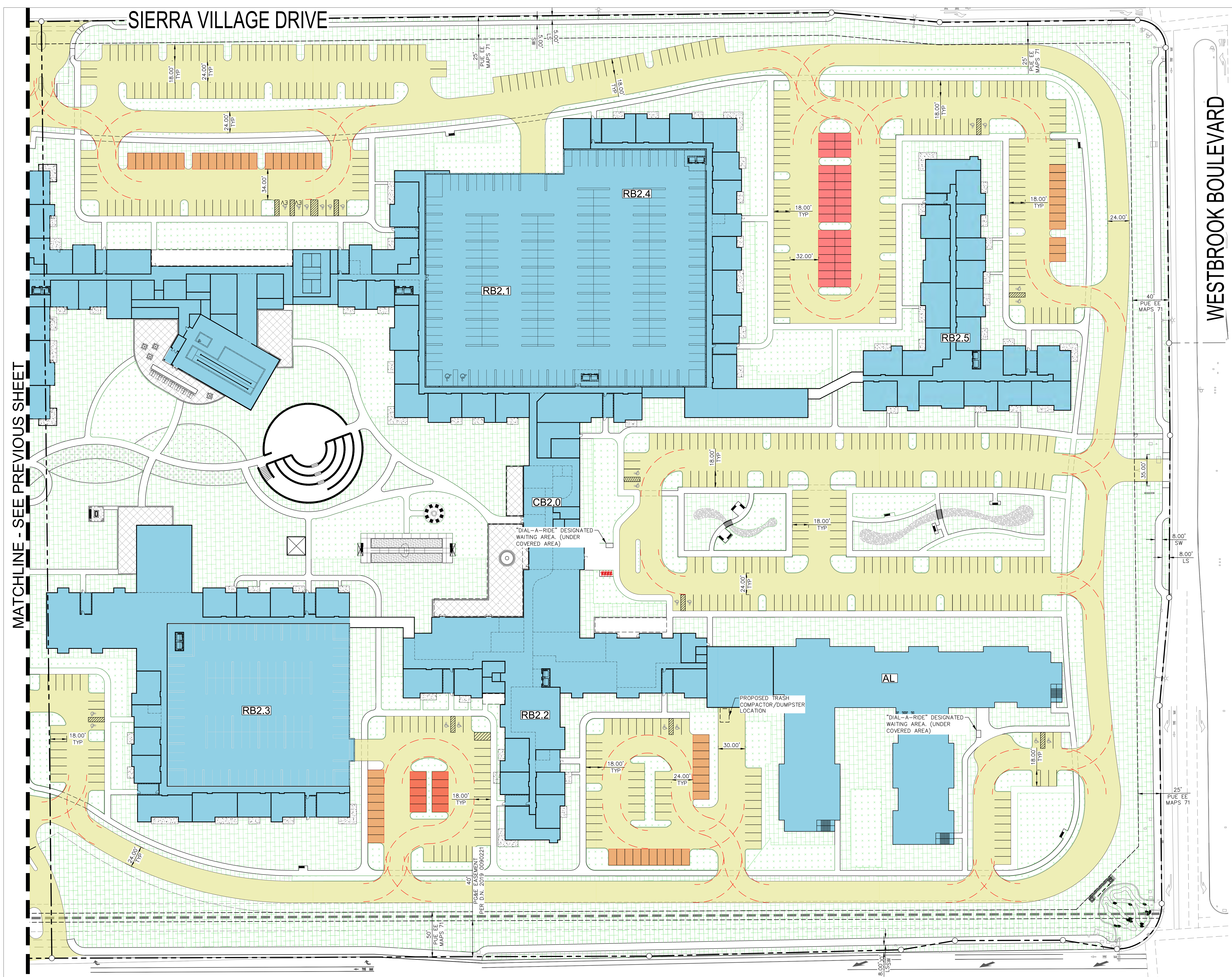
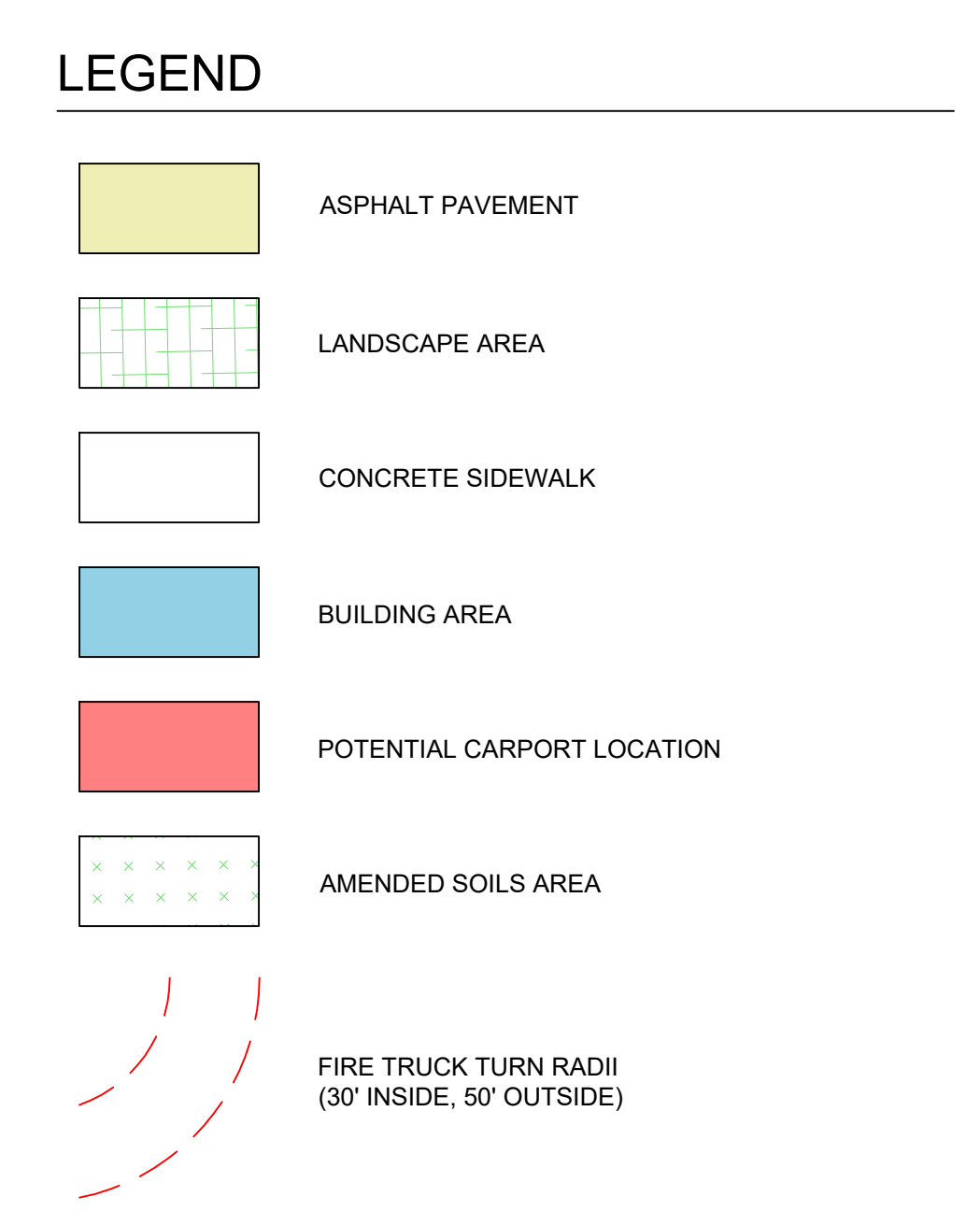
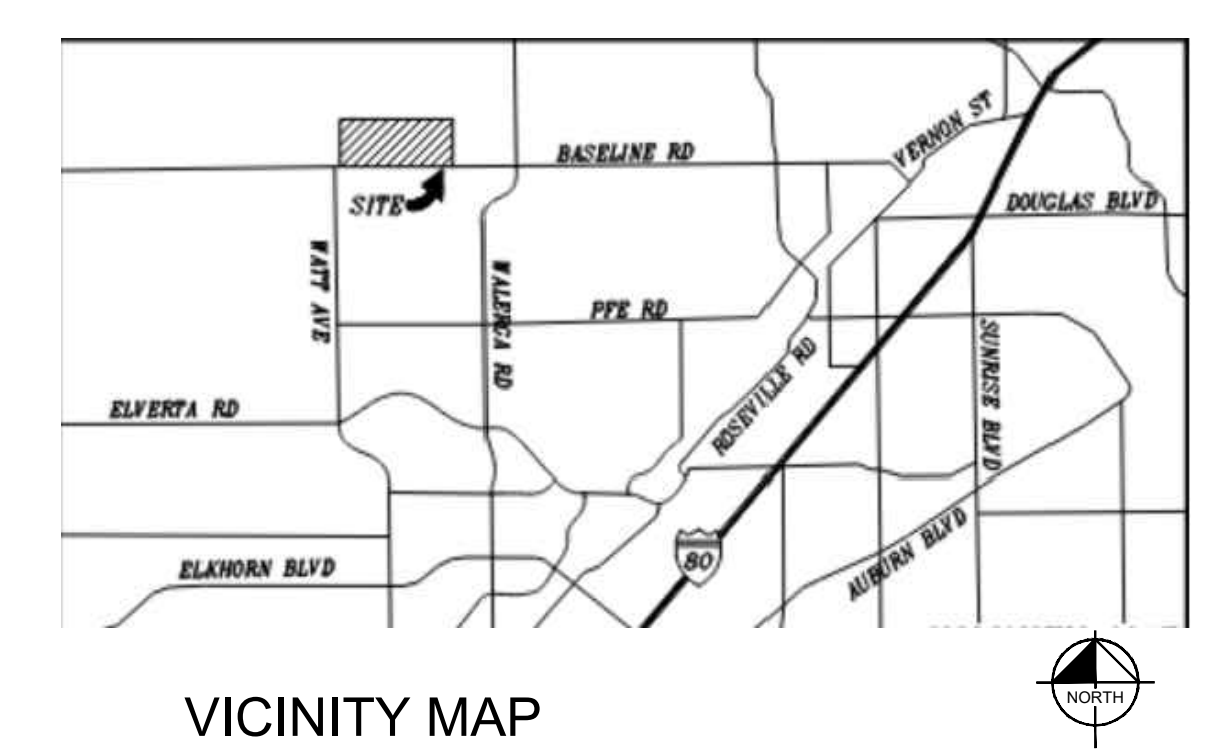

MATCHLINE - SEE PREVIOUS SHEET

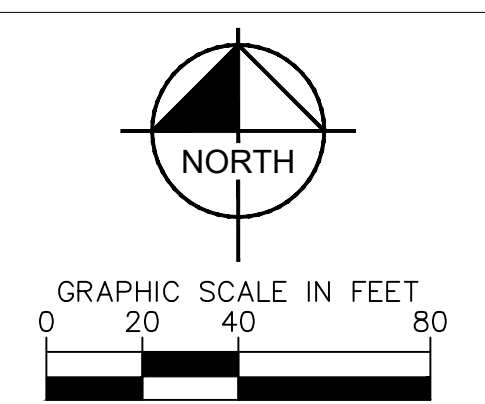

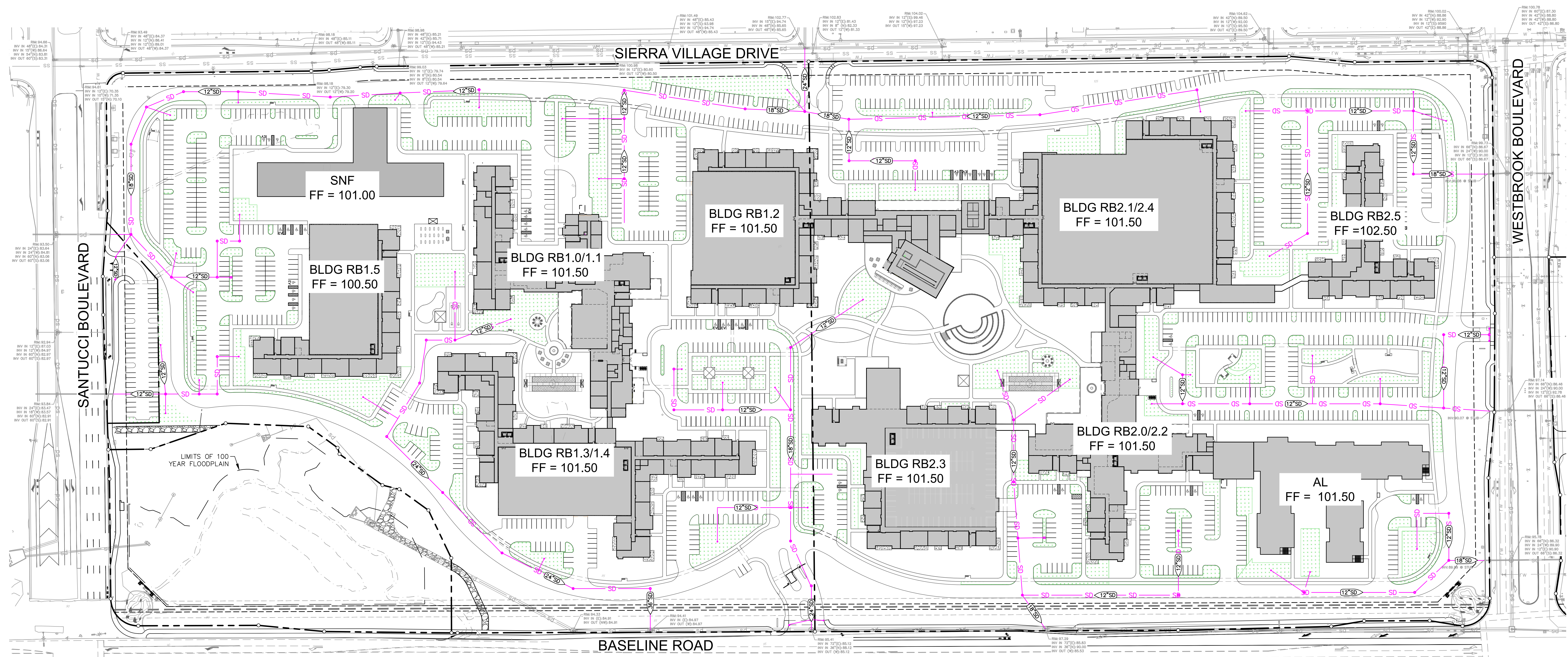

LEGEND





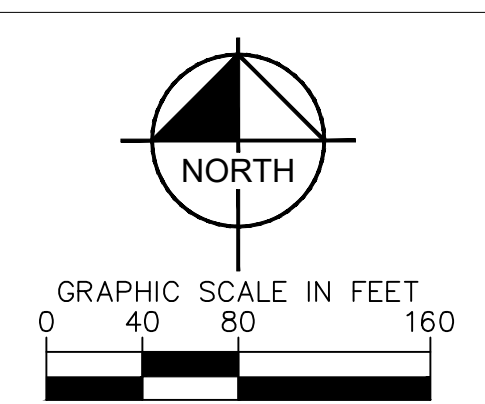

	CENTERLINE
	PROPERTY LINE
	RIGHT-OF-WAY LINE
	EASEMENT / SETBACK LINE
	APPROXIMATE CIVIL LIMIT OF WORK LINE
	PROPOSED STORM DRAIN PIPE
	EXISTING STORM DRAIN PIPE
	FLOW LINE
	LIMITS OF 100 YEAR FLOOD PLAN
	AMENDED SOILS AREA

VERTICAL DATUM
 NGVD 29 AS ADJUSTED TO THE COUNTY OF PLACER CITY BENCHMARK 126 (118.03) BEING A 3-1/4" BRASS DISK STAMPED SEPTEMBER 2014, LS-7331 LOCATED AT THE NORTHEAST CORNER OF THE INTERSECTION OF FIDDYMENT ROAD AND WESTLAKE DRIVE ON THE TOP OF CURB AT NORTH CURB RETURN.

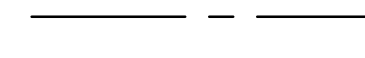
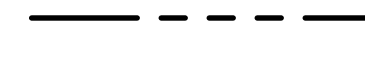
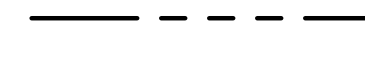
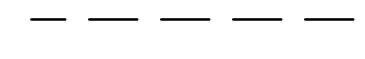
6000 BASELINE ROAD
 ERICKSON SENIOR LIVING ROSEVILLE
MPP STAGE 1: GRADING PLAN

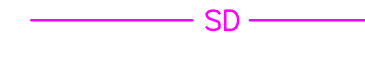

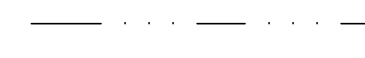

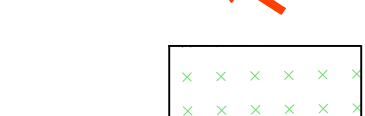

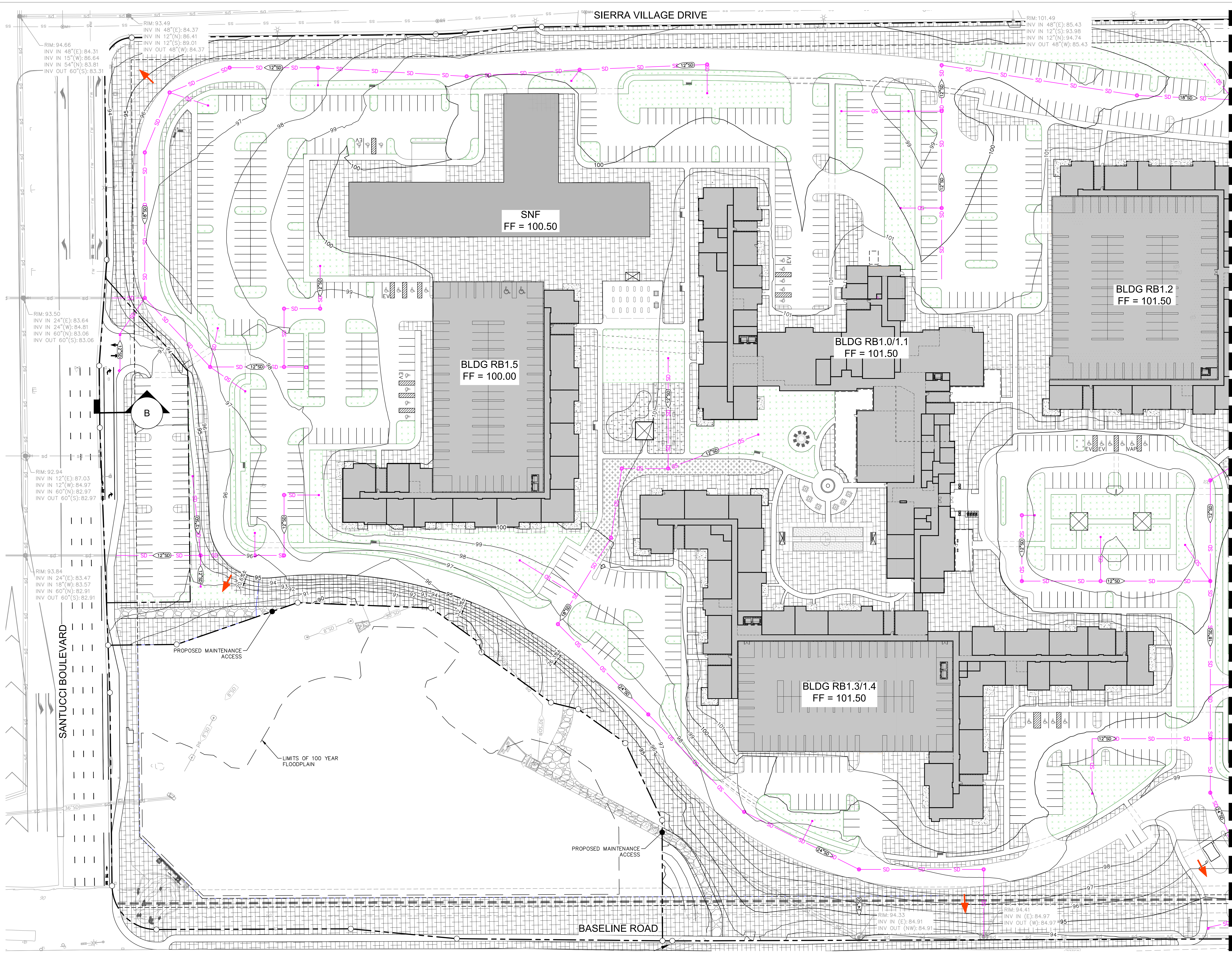

LEGEND

-  CENTERLINE
-  PROPERTY LINE
-  RIGHT-OF-WAY LINE
-  EASEMENT / SETBACK LINE
-  APPROXIMATE CIVIL LIMIT OF WORK LINE
-  PROPOSED STORM DRAIN PIPE
-  EXISTING STORM DRAIN PIPE
-  FLOW LINE
-  OVERLAND RELEASE
-  AMENDED SOILS AREA

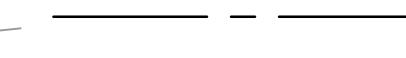
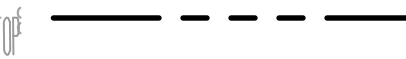
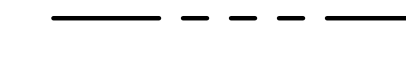
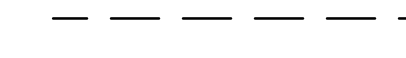

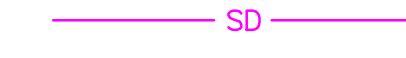
MATCHLINE - SEE NEXT SHEET

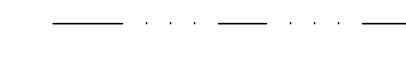
LEGEND

-  CENTERLINE
-  PROPERTY LINE
-  RIGHT-OF-WAY LINE
-  EASEMENT / SETBACK LINE
-  APPROXIMATE CIVIL LIMIT OF WORK LINE
-  PROPOSED STORM DRAIN PIPE
-  EXISTING STORM DRAIN PIPE
-  FLOW LINE
-  OVERLAND RELEASE
-  AMENDED SOILS AREA

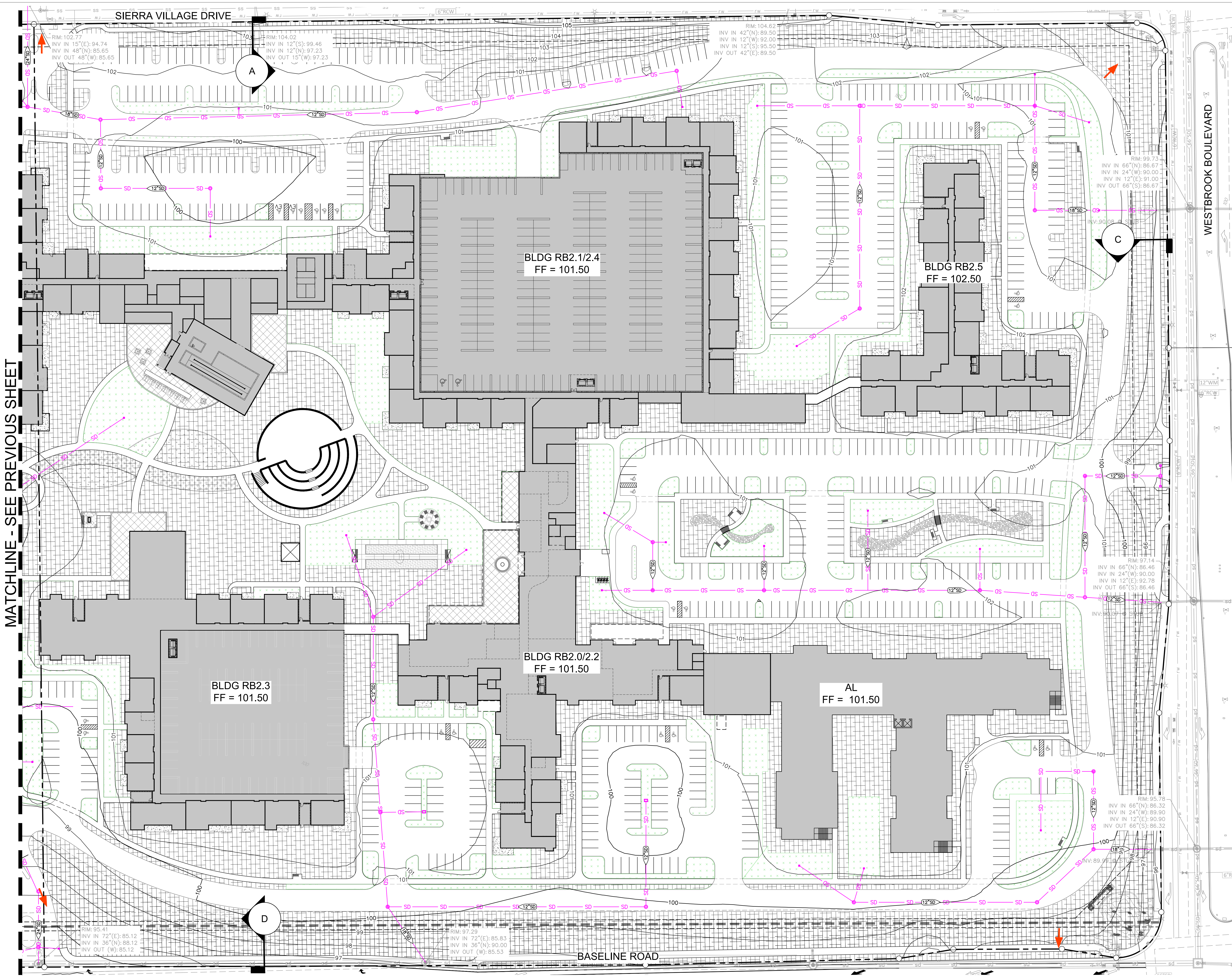

MATCHLINE - SEE PREVIOUS SHEET

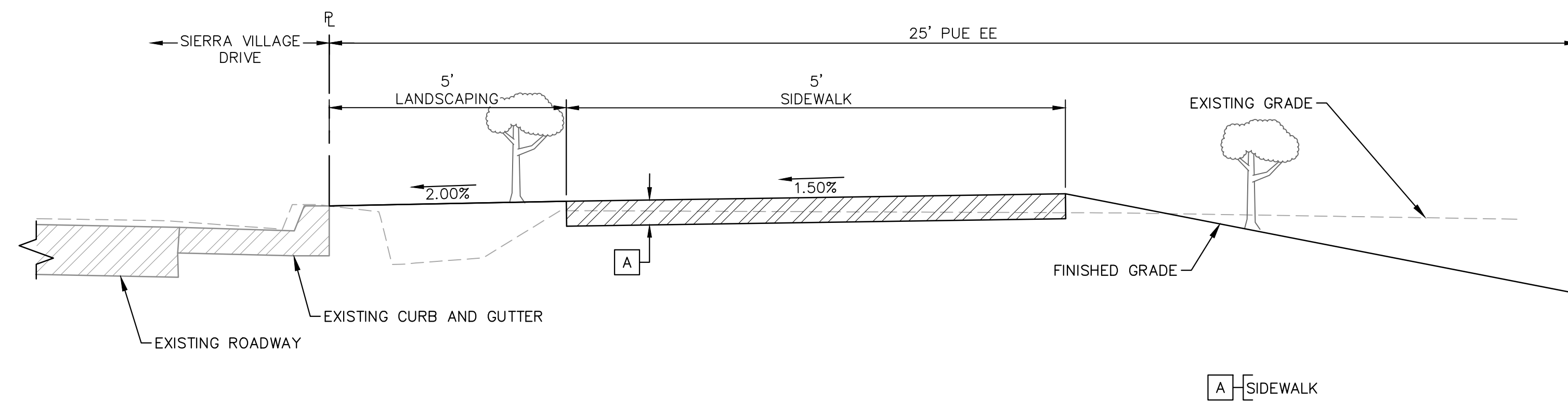

(A) SECTION THRU SIERRA VILLAGE DRIVE
NTS

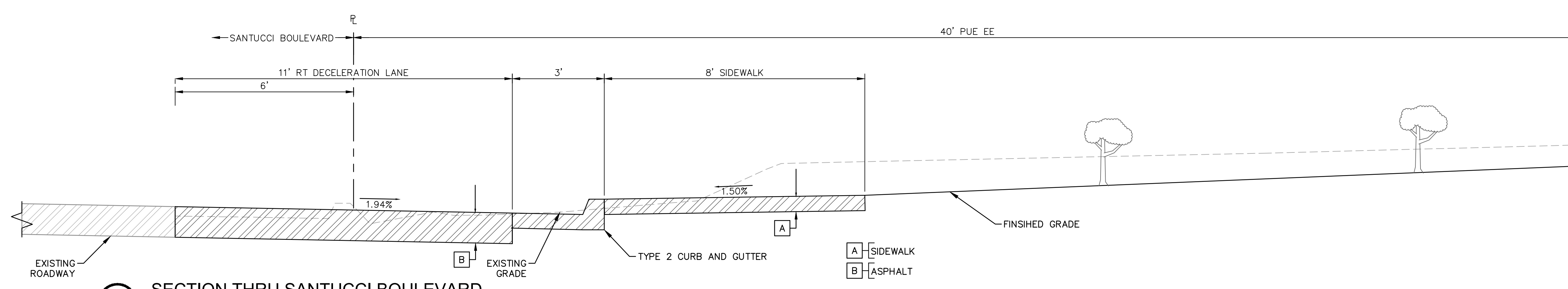

(B) SECTION THRU SANTUCCI BOULEVARD
NTS

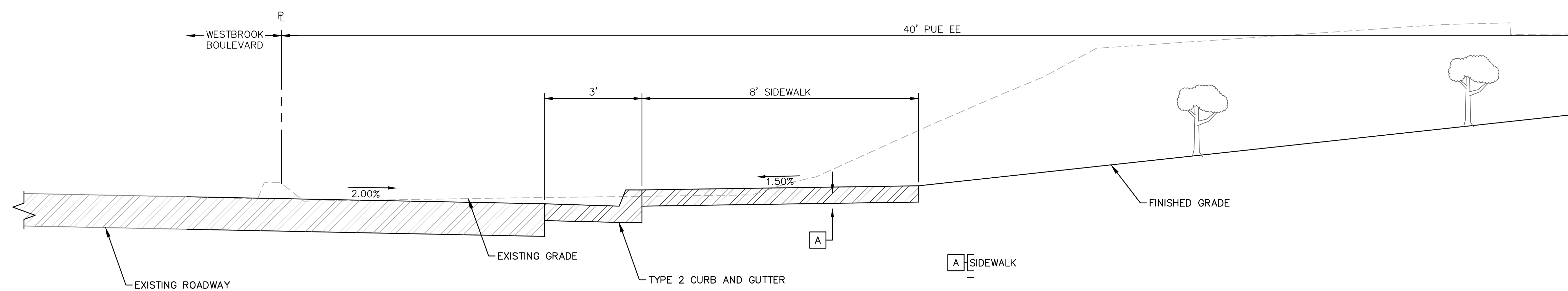

(C) SECTION THRU WESTBROOK BOULEVARD
NTS

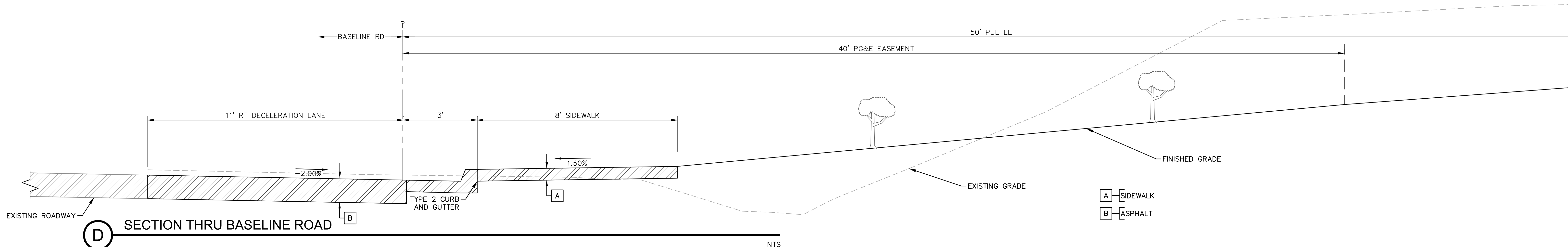

(D) SECTION THRU BASELINE ROAD
NTS

A SIDEWALK
B ASPHALT

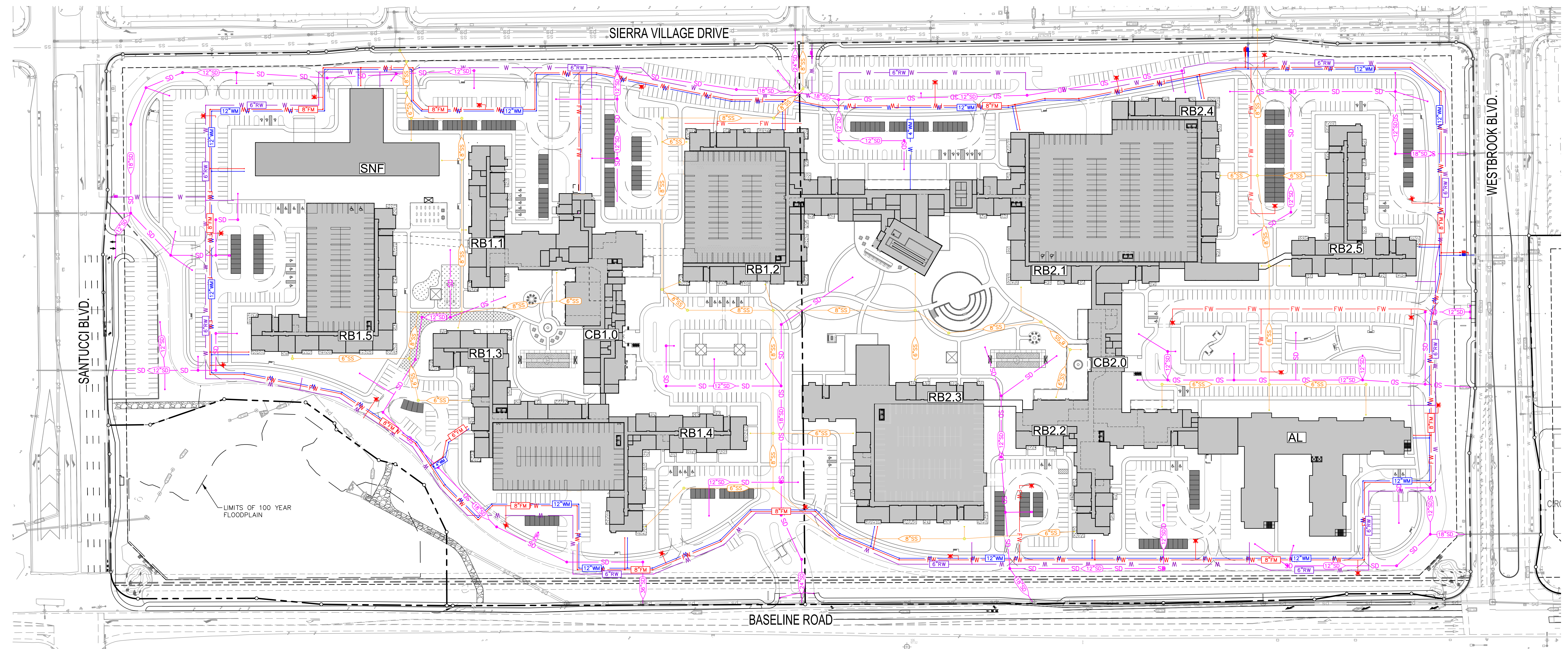

LEGEND

- **SS** 8"SS PROPOSED SEWER LINE
- **SD** 12"SD PROPOSED STORM DRAIN LINE
- **W** 12"WM PROPOSED WATER LINE
- **FW** 8"FM PROPOSED FIRE WATER LINE
- **W** 6"RW PROPOSED RECLAIMED WATER LINE
- PROPOSED STORM DRAIN MANHOLE
- PROPOSED SEWER MANHOLE
- PROPOSED FIRE HYDRANT
- PROPOSED DOUBLE CHECK DETECTOR VALVE AND WATER METER

6000 BASELINE ROAD
 ERICKSON SENIOR LIVING ROSEVILLE
MPP STAGE 1: WET UTILITIES PLAN

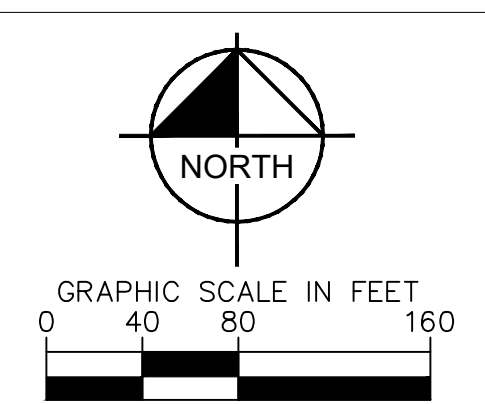





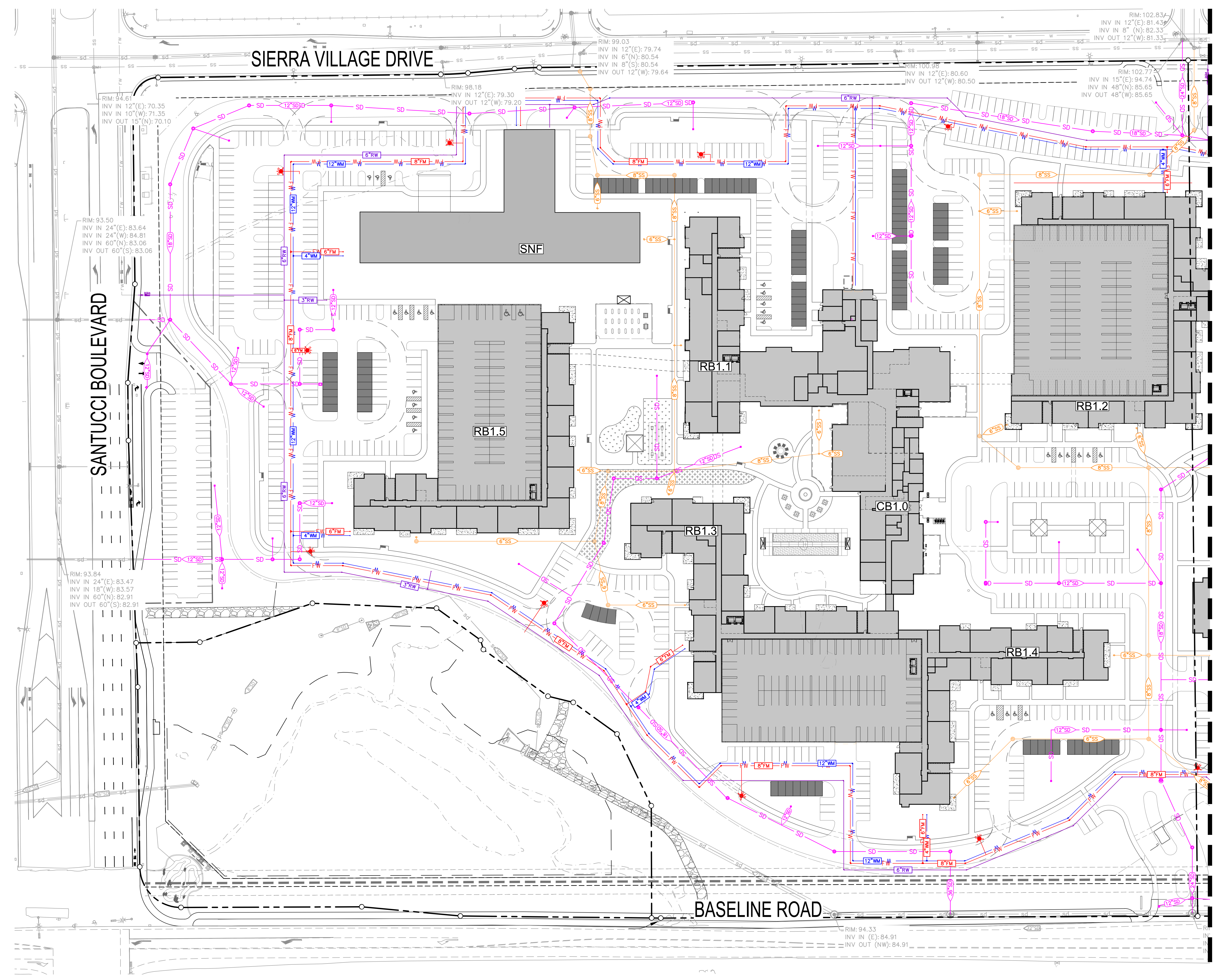



LEGEND

	PROPOSED SEWER LINE
	PROPOSED STORM DRAIN LINE
	PROPOSED WATER LINE
	PROPOSED FIRE WATER LINE
	PROPOSED RECLAIMED WATER LINE
	PROPOSED STORM DRAIN MANHOLE
	PROPOSED SEWER MANHOLE
	PROPOSED FIRE HYDRANT
	PROPOSED DOUBLE CHECK DETECTOR VALVE AND WATER METER



MATCHLINE - SEE NEXT SHEET

LEGEND

	SS	8" SS	PROPOSED SEWER LINE
	SD	12" SD	PROPOSED STORM DRAIN LINE
	W	12" W	PROPOSED WATER LINE
	FW	8" FW	PROPOSED FIRE WATER LINE
	W	12" RW	PROPOSED RECLAIMED WATER LINE
			PROPOSED STORM DRAIN MANHOLE
			PROPOSED FIRE HYDRANT
			PROPOSED DOUBLE CHECK DETECTOR VALVE AND WATER METER

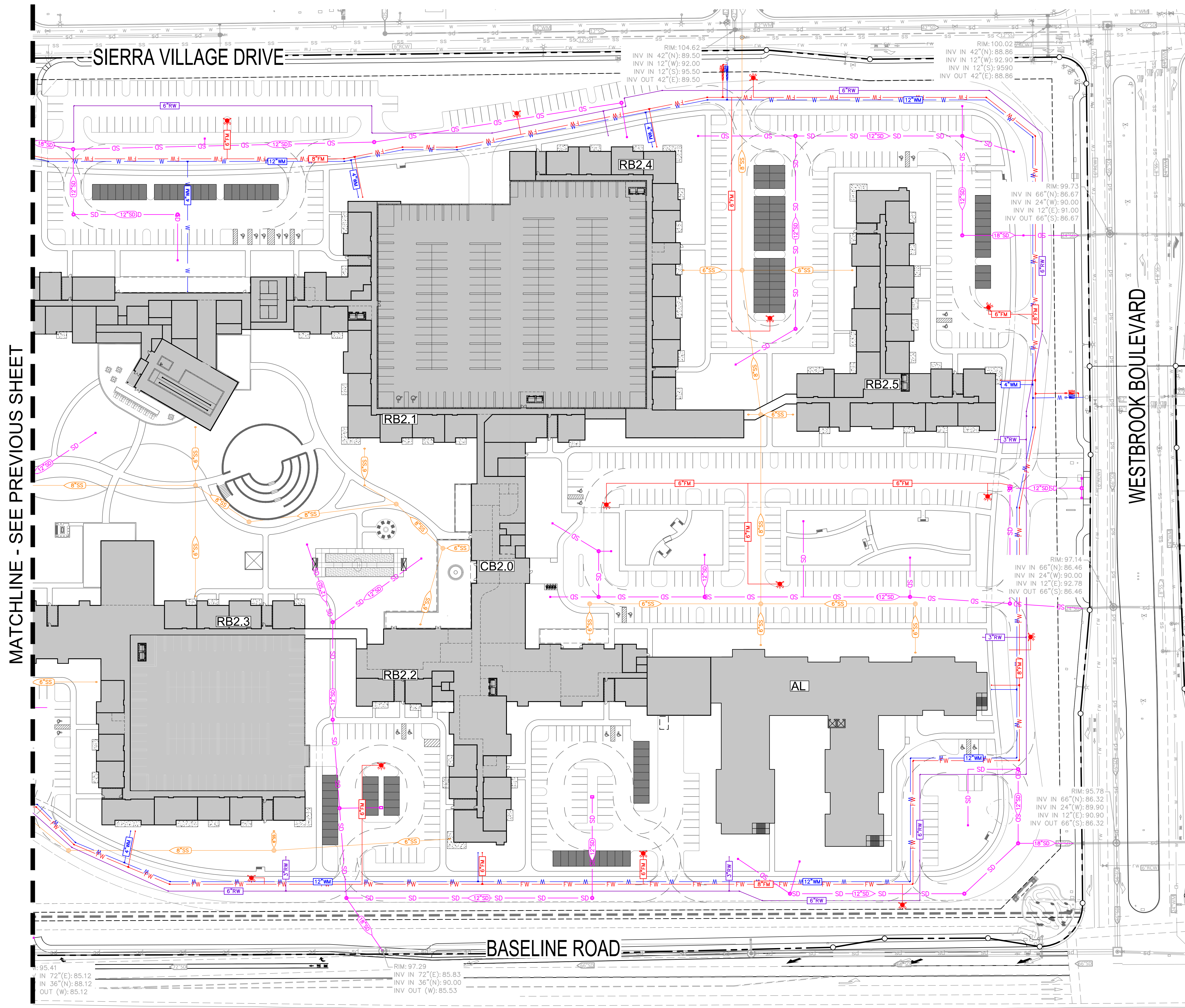

MATCHLINE - SEE PREVIOUS SHEET

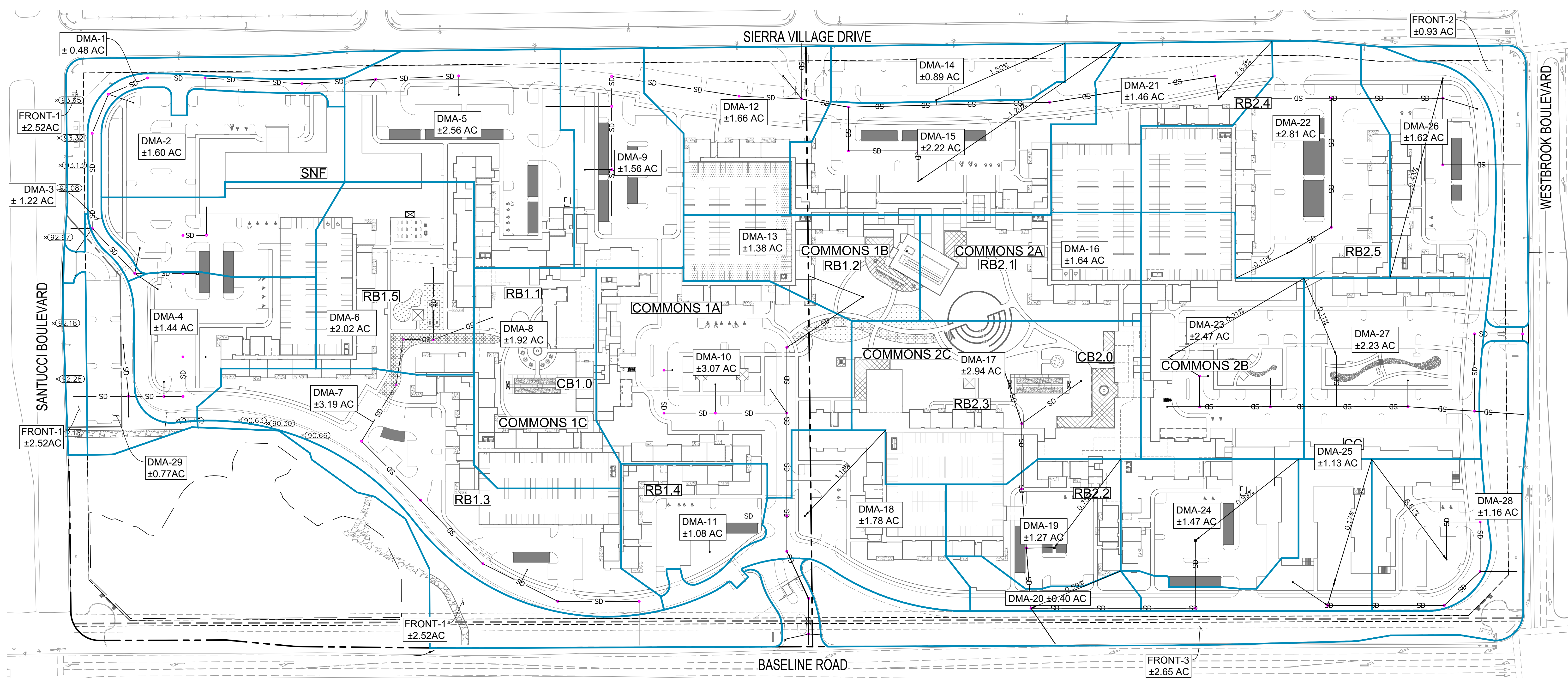

LEGEND



- DRAINAGE MANAGEMENT AREA (DMA)
- LANDSCAPE AREA
- AMENDED SOILS AREA

NOTES

1. LOCATION OF AMENDED SOIL TO BE DETERMINED DURING FINAL DESIGN.
2. PRELIMINARY TREE PLANTING LOCATIONS PER LANDSCAPE PLANS.

ERICKSON WEST ROSEVILLE - PRELIMINARY STORMWATER COMPLIANCE SUMMARY TABLE							
SHED NAME	TOTAL SHED AREA		SITE DESIGN TREATMENT CONTROLS	EFFECTIVE TREATED IMPERVIOUS AREA (SF) ²	IMPERVIOUS AREA UNTREATED BY SITE DESIGN MEASURES (SF)	Amended Soil Area	Percent of Pervious Area
	PERVIOUS AREA (SF)	IMPERVIOUS AREA (SF)					
1	-	20,993.00	DISCONNECTED ROOF DRAINS, AMENDED SOIL, TREE PLANTINGS ³	21,095.00	0	4100	
2	33,235.00	36,372.00		36,483.00	0	5500	17%
3	15,140.00	37,965.00		38,058.00	0	6000	40%
4	11,418.00	51,471.00		51,777.00	0	8500	74%
5	38,400.00	73,124.00		73,304.00	0	11,900	29%
6	27,322.00	60,645.00		60,861.00	0	7900	29%
7	35,548.00	103,361.00		103,903.00	0	16000	45%
8	20,170.00	63,671.00		63,864.00	0	7400	37%
9	23,969.00	43,875.00		44,134.00	0	7600	32%
10	43,888.00	89,574.00		90,867.00	0	14000	32%
11	14,436.00	32,563.00		32,651.00	0	4850	34%
12	25,016.00	47,192.00		47,313.00	0	6400	26%
13	16,057.00	44,107.00		44,120.00	0	4800	30%
14	17,617.00	20,977.00		21,130.00	0	3750	21%
15	32,693.00	63,911.00		63,943.00	0	9750	30%
16	25,406.00	45,836.00		45,856.00	0	4300	17%
17	53,545.00	74,412.00		74,750.00	0	8700	16%
18	18,841.00	58,747.00		58,752.00	0	8650	46%
19	11,455.00	43,915.00		44,059.00	0	6100	53%
20	6,142.00	11,461.00		11,468.00	0	2100	34%
21	15,248.00	48,540.00		48,774.00	0	6800	45%
22	28,475.00	93,710.00		93,756.00	0	13500	47%
23	28,194.00	79,473.00		80,149.00	0	11000	39%
24	14,259.00	49,349.00		49,467.00	0	7300	49%
25	13,983.00	35,174.00		35,251.00	0	5100	37%
26	18,825.00	51,774.00		51,964.00	0	8500	45%
27	31,224.00	66,056.00		66,180.00	0	11150	36%
28	11,367.00	39,152.00		39,329.00	0	6300	55%
29	16,360.10	17,383.40		21,610.00	0	6301	39%
FRONT 1 ¹	109,679.50	-	-	-	-	-	-
FRONT 2 ²	40,361.00	-	-	-	-	-	-
FRONT 3 ³	115,497.00	-	-	-	-	-	-
SubTotal	914,234.60	1,505,086.40	-	-	-	-	-
TOTAL	2,439,321.00	-	-	-	-	-	-

1. SITE DESIGN VOLUME REDUCED BY 10% AT OUTLET PER FORM 3 OF THE WEST FLORIDA STORMWATER TREATMENT.
 2. AS CALCULATED ON FORM 3.4 OF THE WEST FLORIDA STORMWATER TREATMENT.
 3. FRONTAGE DRAINAGE MANAGEMENT AREAS ARE CONSIDERED TO BE SELF-TREATING AND 100% PERVIOUS.

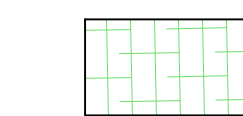
-  PRIMARY PEDESTRIAN PATHWAY
-  ASPHALT PAVEMENT
-  LANDSCAPE AREA

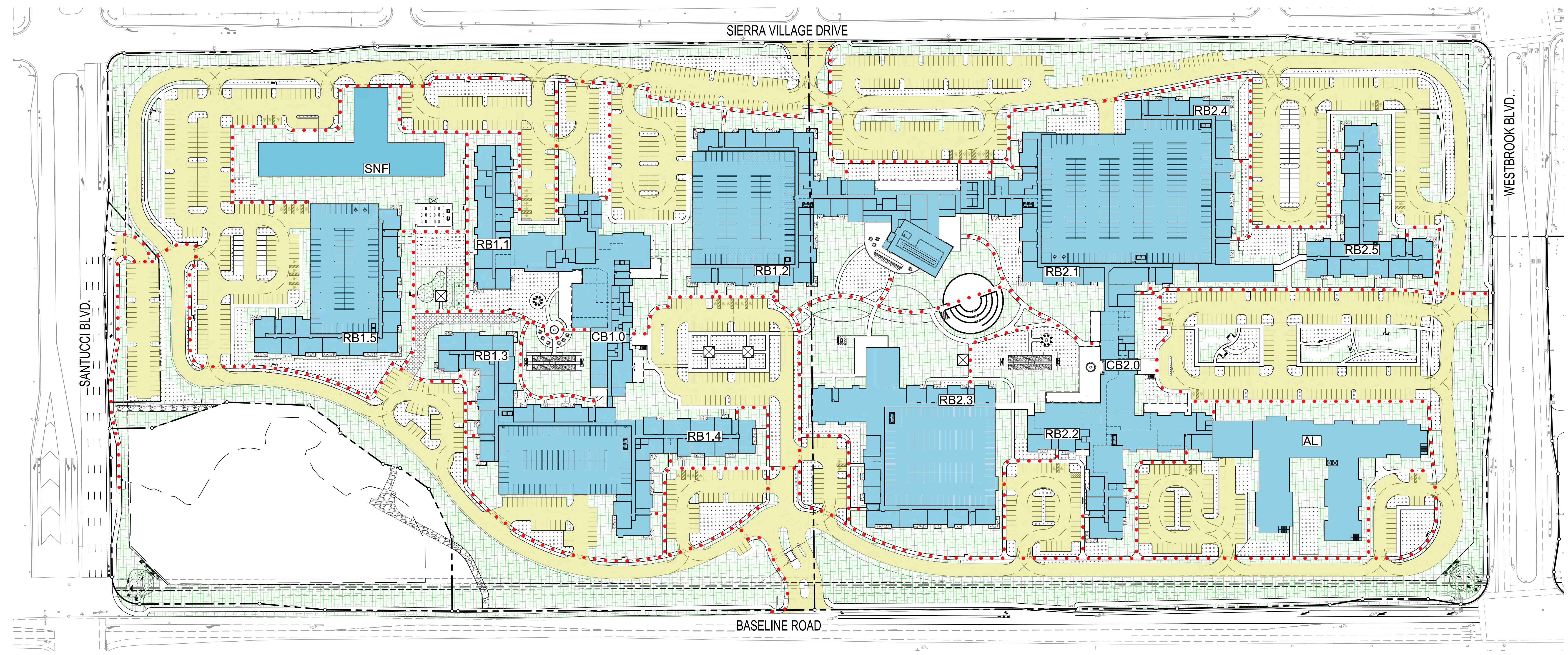

6000 BASELINE ROAD
ERICKSON SENIOR LIVING ROSEVILLE

Pedestrian Plan

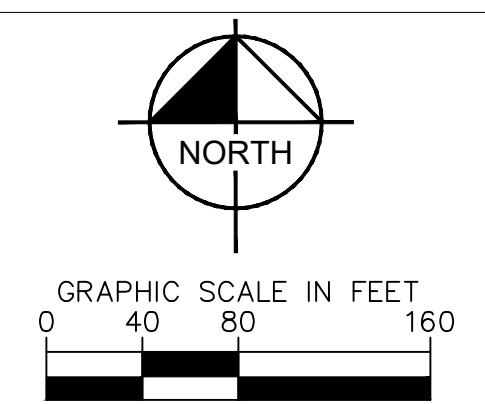

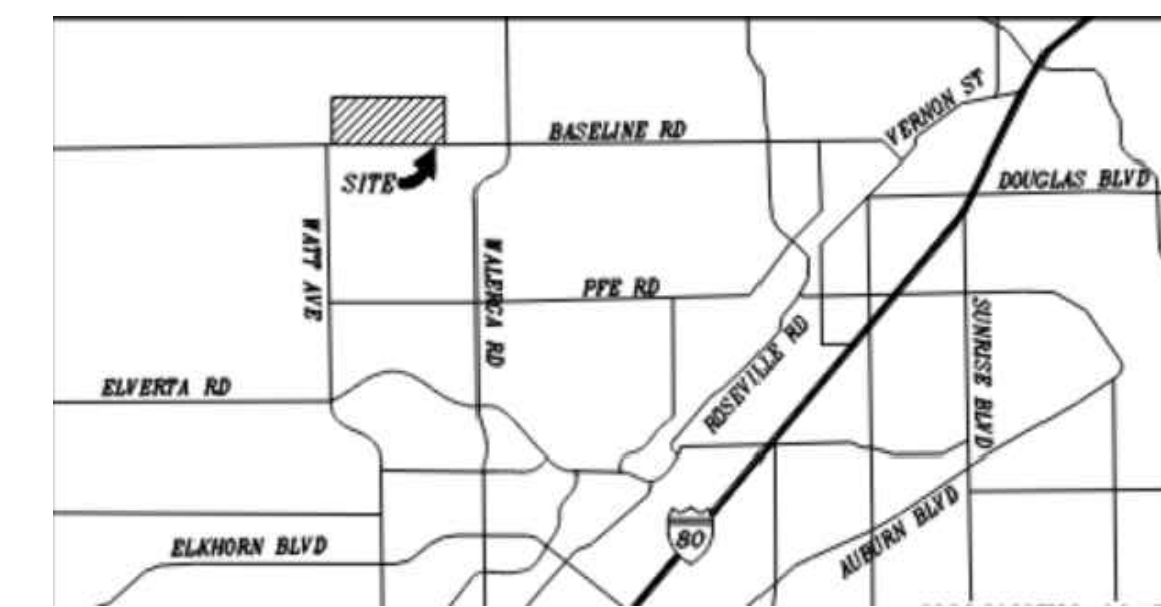

VICINITY MAP

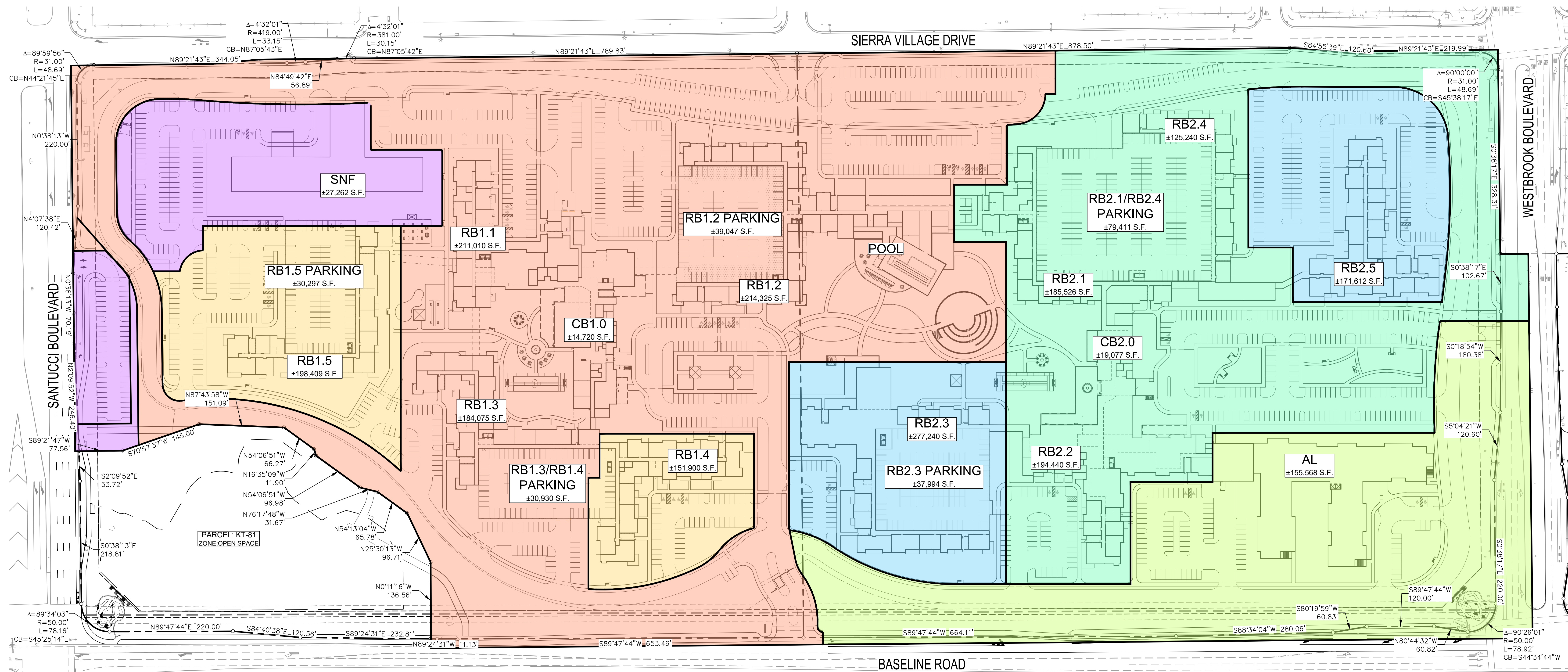

LEGEND

- PHASE 1
- PHASE 2
- PHASE 3
- PHASE 4
- PHASE 5
- PHASE 6

SUMMARY TABLE

PHASE	BUILDINGS	AREA (S.F.)
PHASE 1	RB 1.1	211,010
	CB 1.0	14,720
	RB 1.2	214,325
	RB 1.3	184,075
	TOTAL	624,130
PHASE 2	RB 1.4	151,900
	RB 1.5	198,409
TOTAL	350,309	
PHASE 3	ASSISTED LIVING (AL)	155,568
PHASE 4	RB 2.1	185,528
	CB 2.0	19,077
	RB 2.2	194,440
	RB 2.4	125,240
TOTAL	524,285	
PHASE 5	RB 2.3	277,240
	RB 2.5	171,612
TOTAL	448,852	
PHASE 6	SKILLED NURSING FACILITY PARK AND RIDE LOT	27,262
TOTAL		2,130,406

6000 BASELINE ROAD
ERICKSON SENIOR LIVING ROSEVILLE

MPP STAGE 1: PHASING PLAN

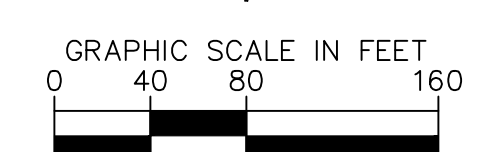
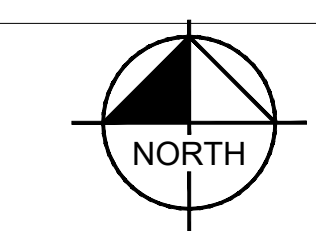

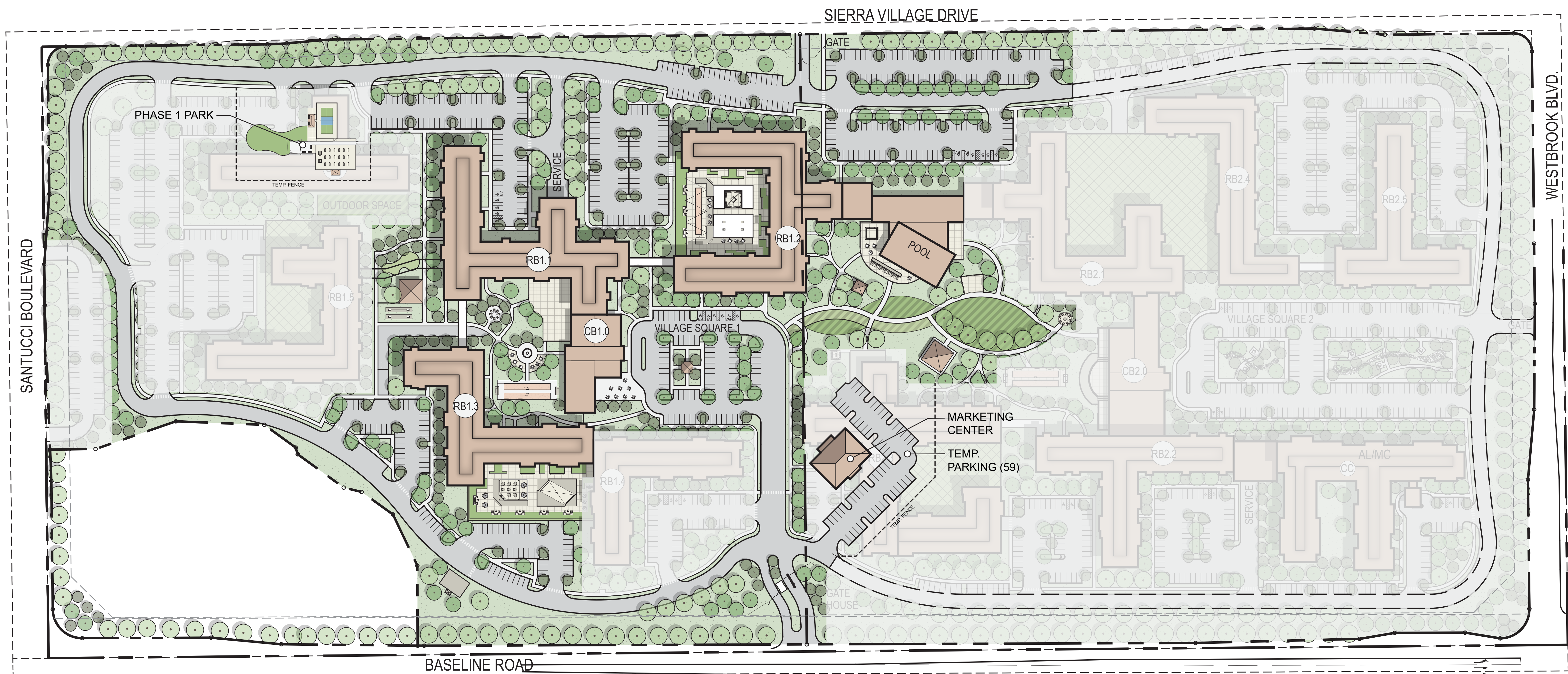

PHASING PLAN - PHASE 1

ERICKSON SENIOR LIVING ROSEVILLE

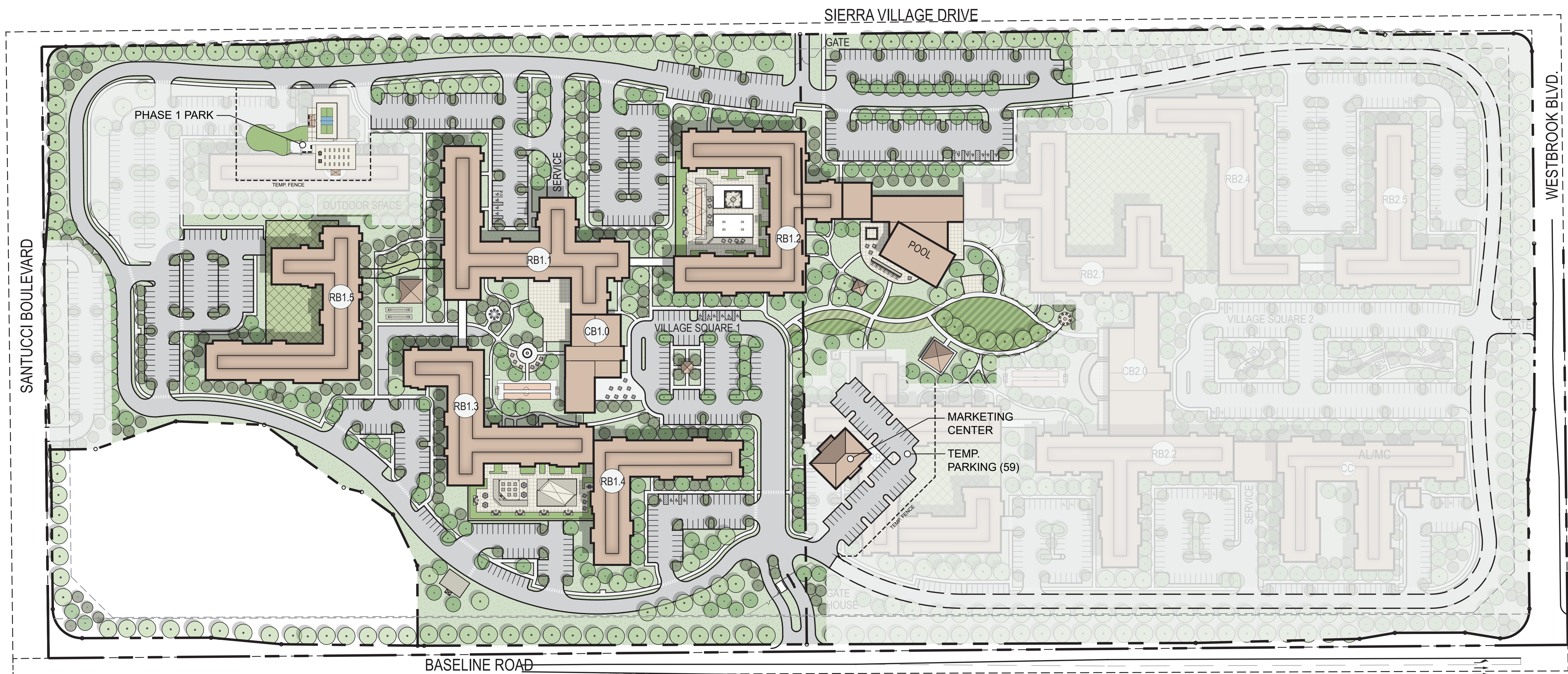

PHASING PLAN - PHASE 2

ERICKSON SENIOR LIVING ROSEVILLE

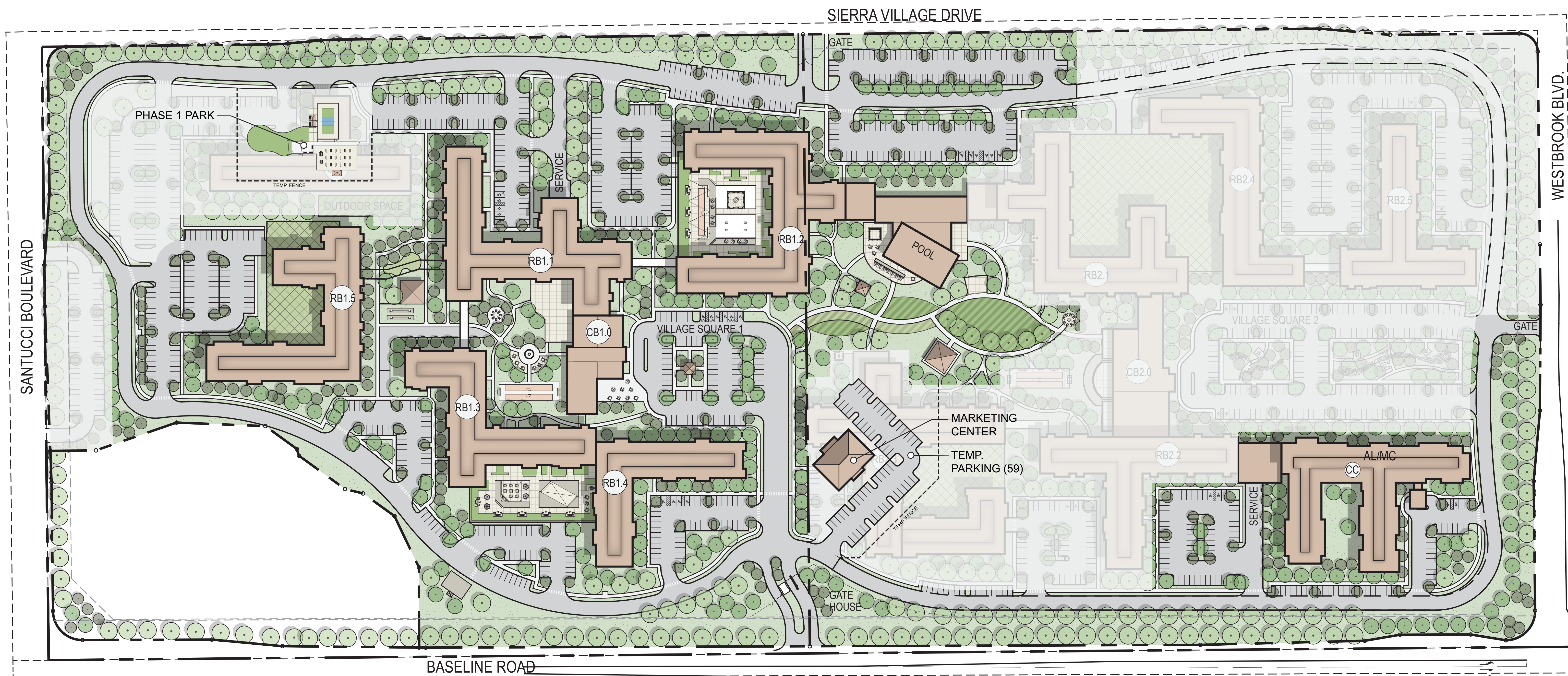

PHASING PLAN - PHASE 3

ERICKSON SENIOR LIVING ROSEVILLE

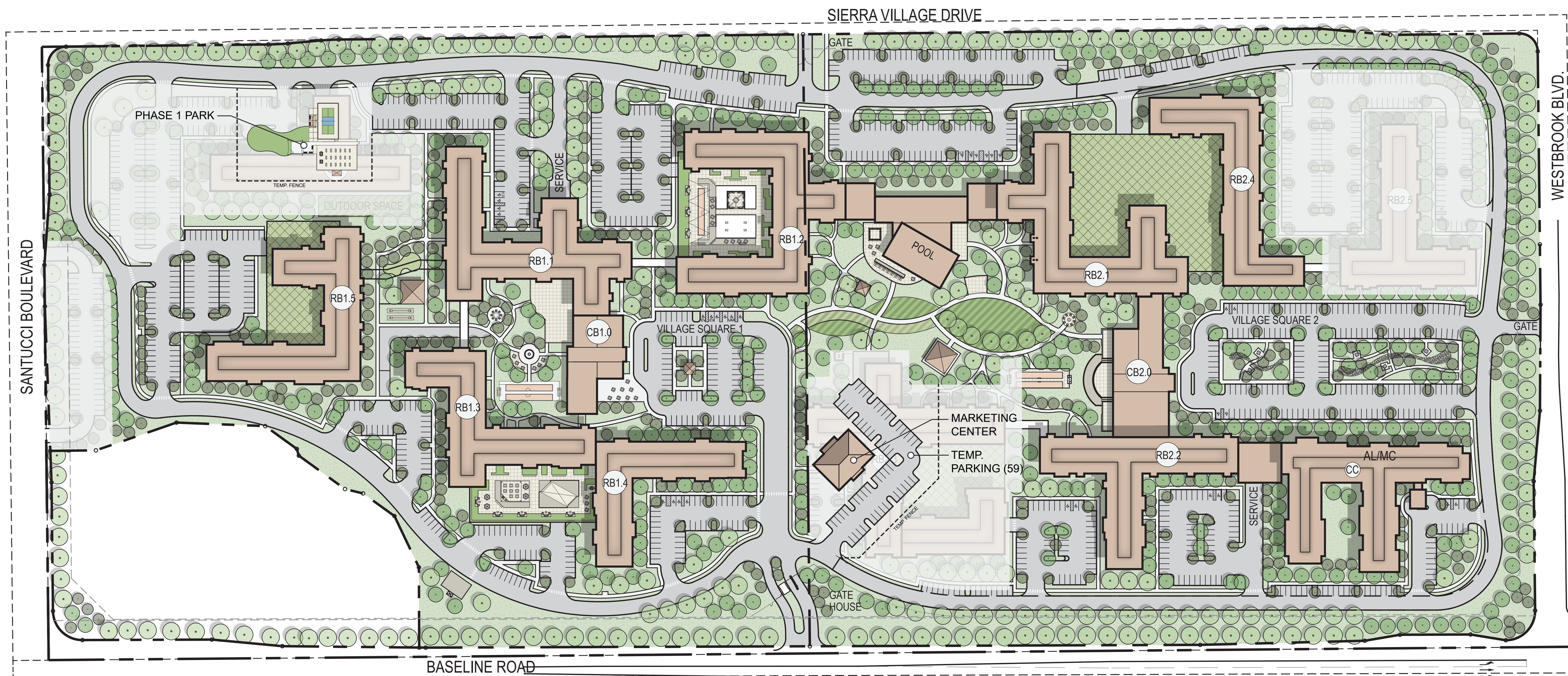

PHASING PLAN - PHASE 4

ERICKSON SENIOR LIVING ROSEVILLE

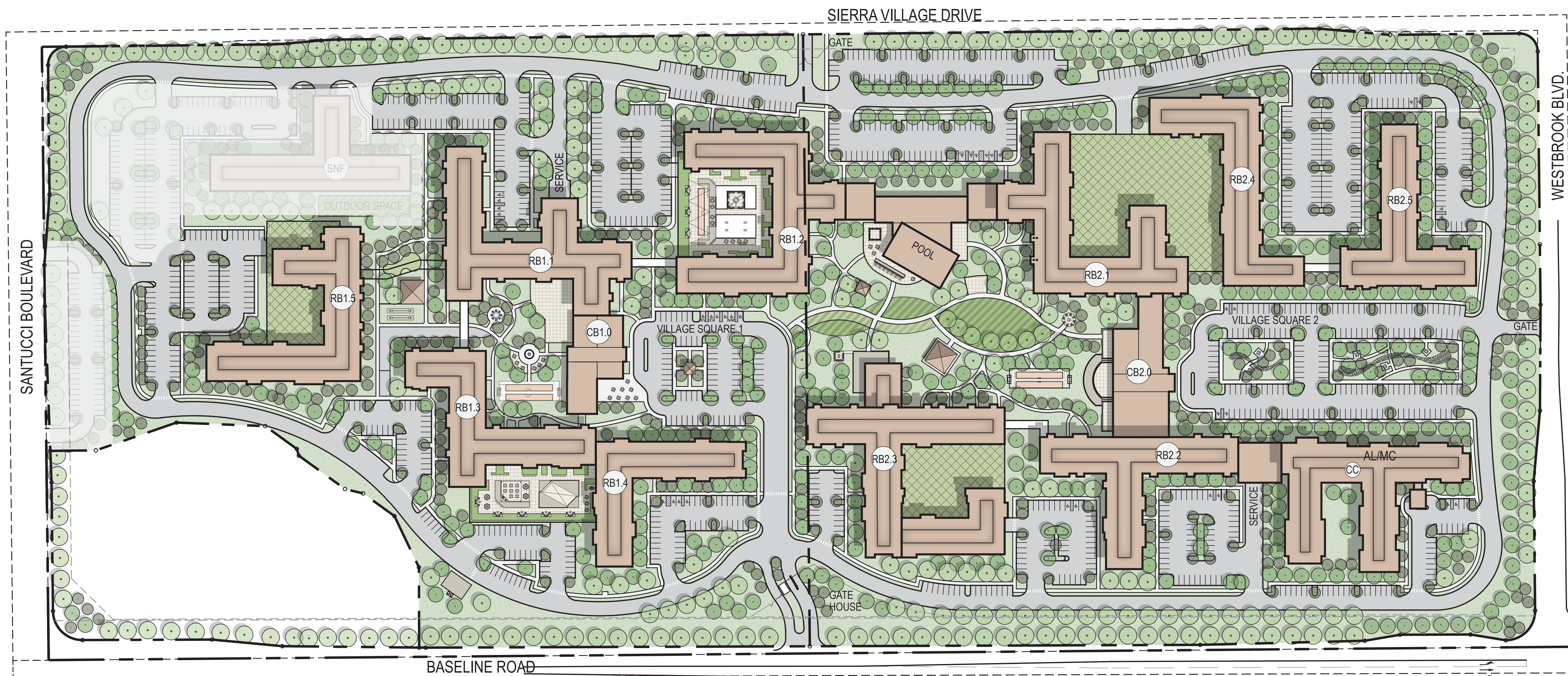

PHASING PLAN - PHASE 5

ERICKSON SENIOR LIVING ROSEVILLE

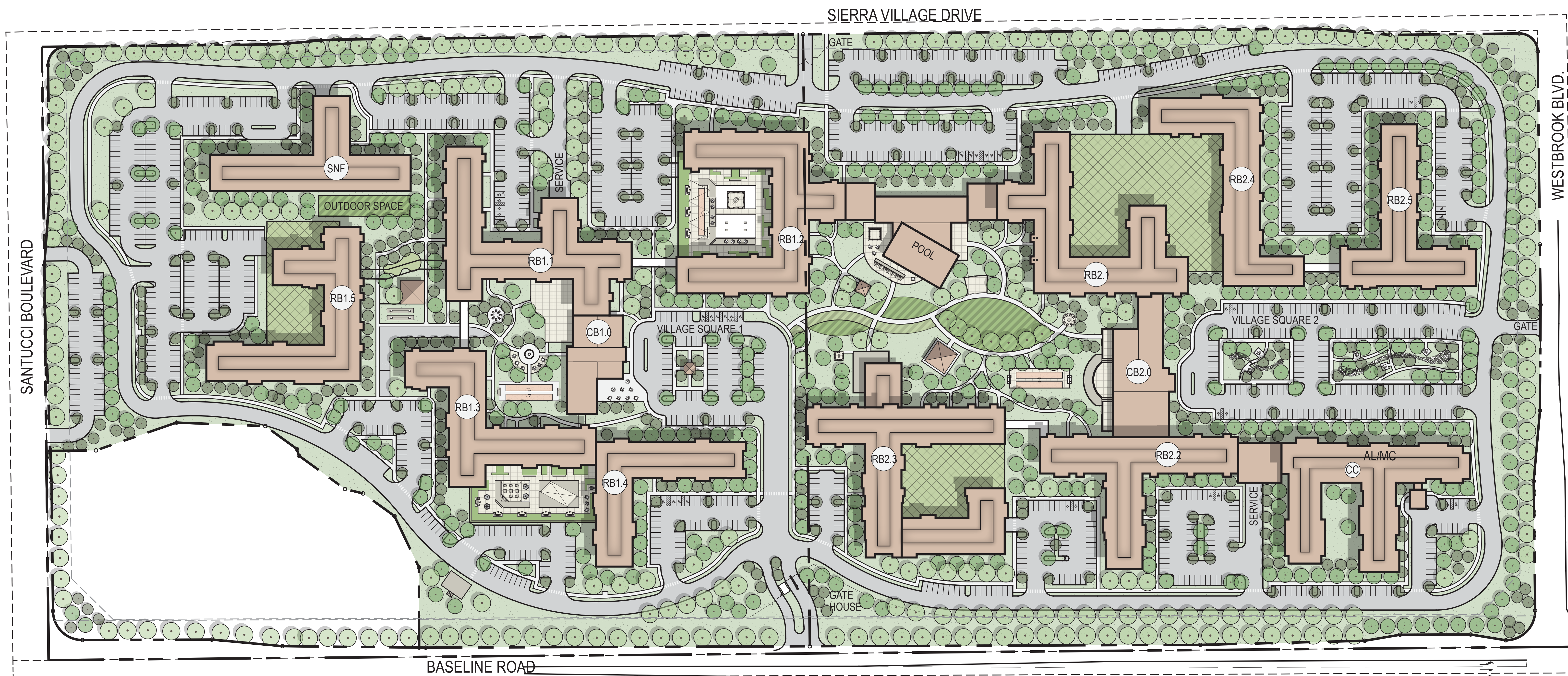

PHASING PLAN - PHASE 6

ERICKSON SENIOR LIVING ROSEVILLE

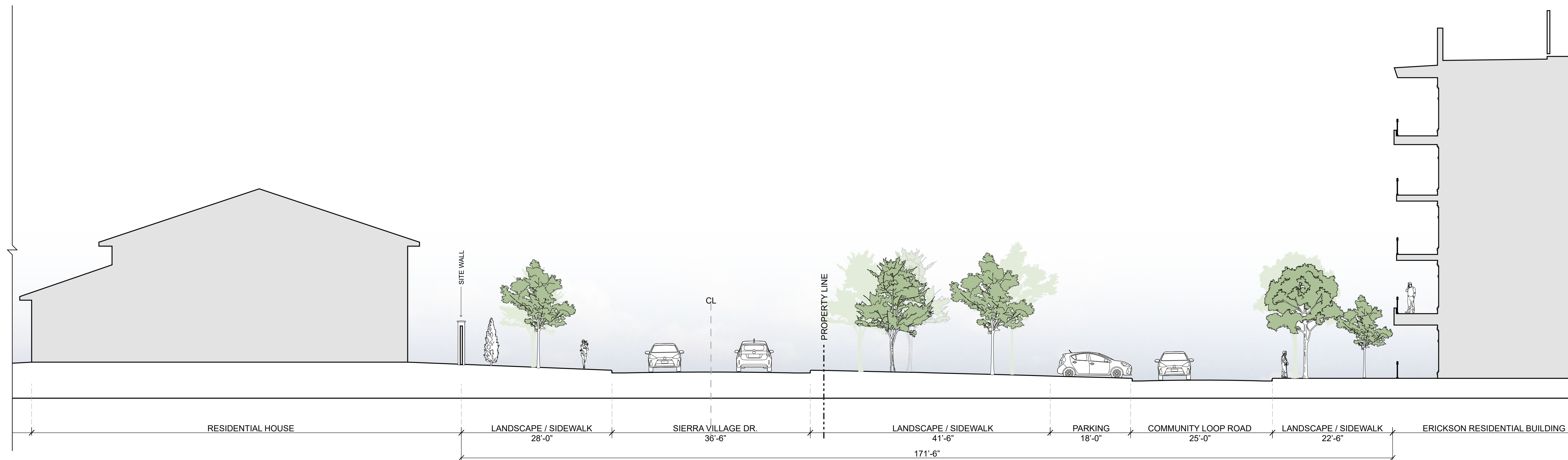

01 / NORTH-SOUTH SITE SECTION
1"=10'

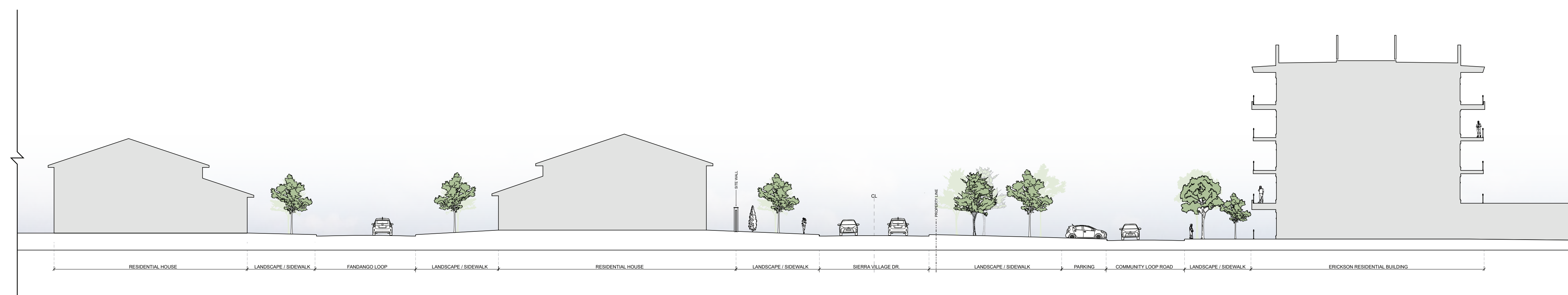

02 / NORTH-SOUTH SITE SECTION (EXPANDED)
1"=20'

STREET SECTION - SIERRA VILLAGE DR.

ERICKSON SENIOR LIVING ROSEVILLE

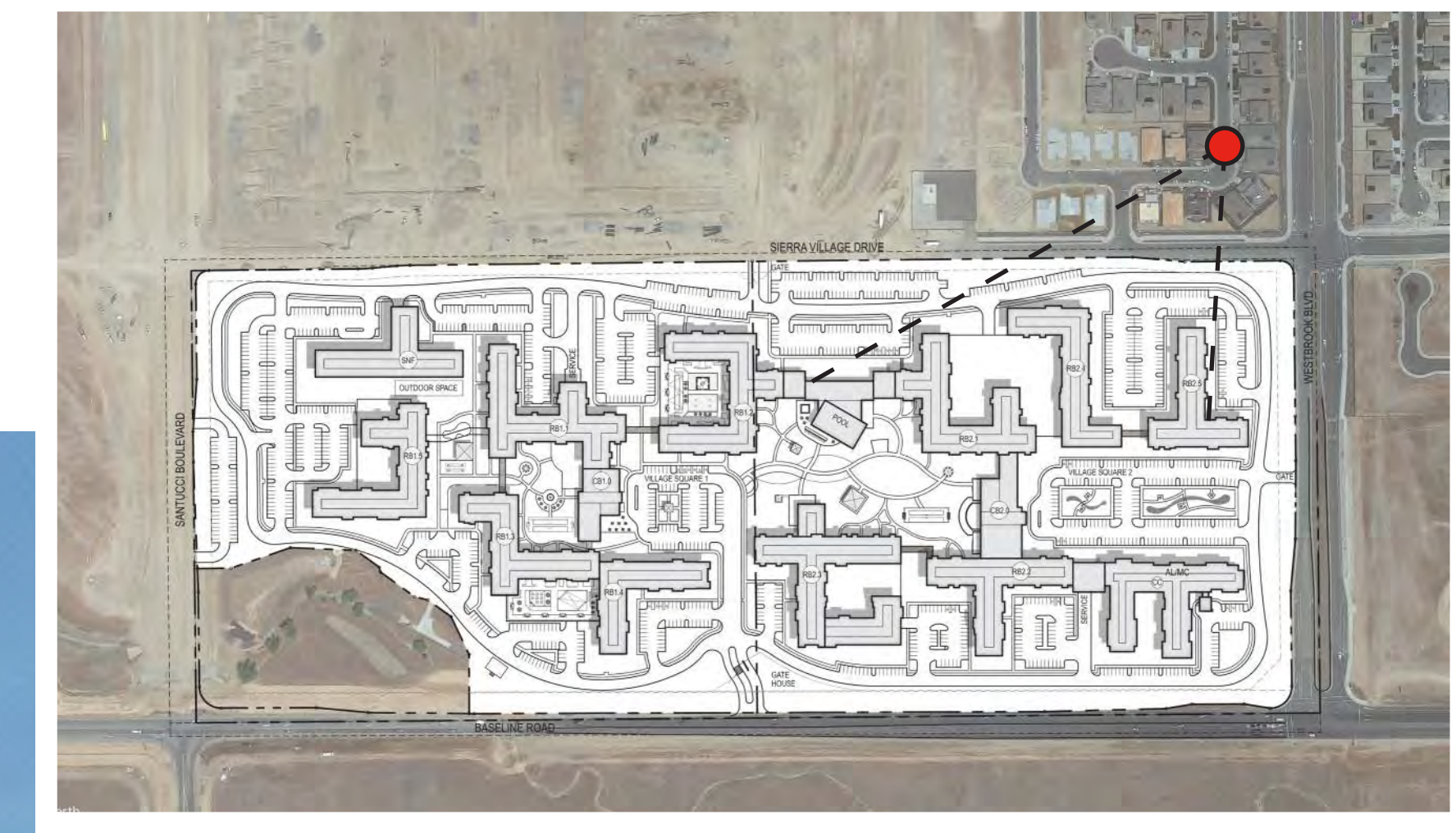

VIEW FROM FANDANGO LOOP

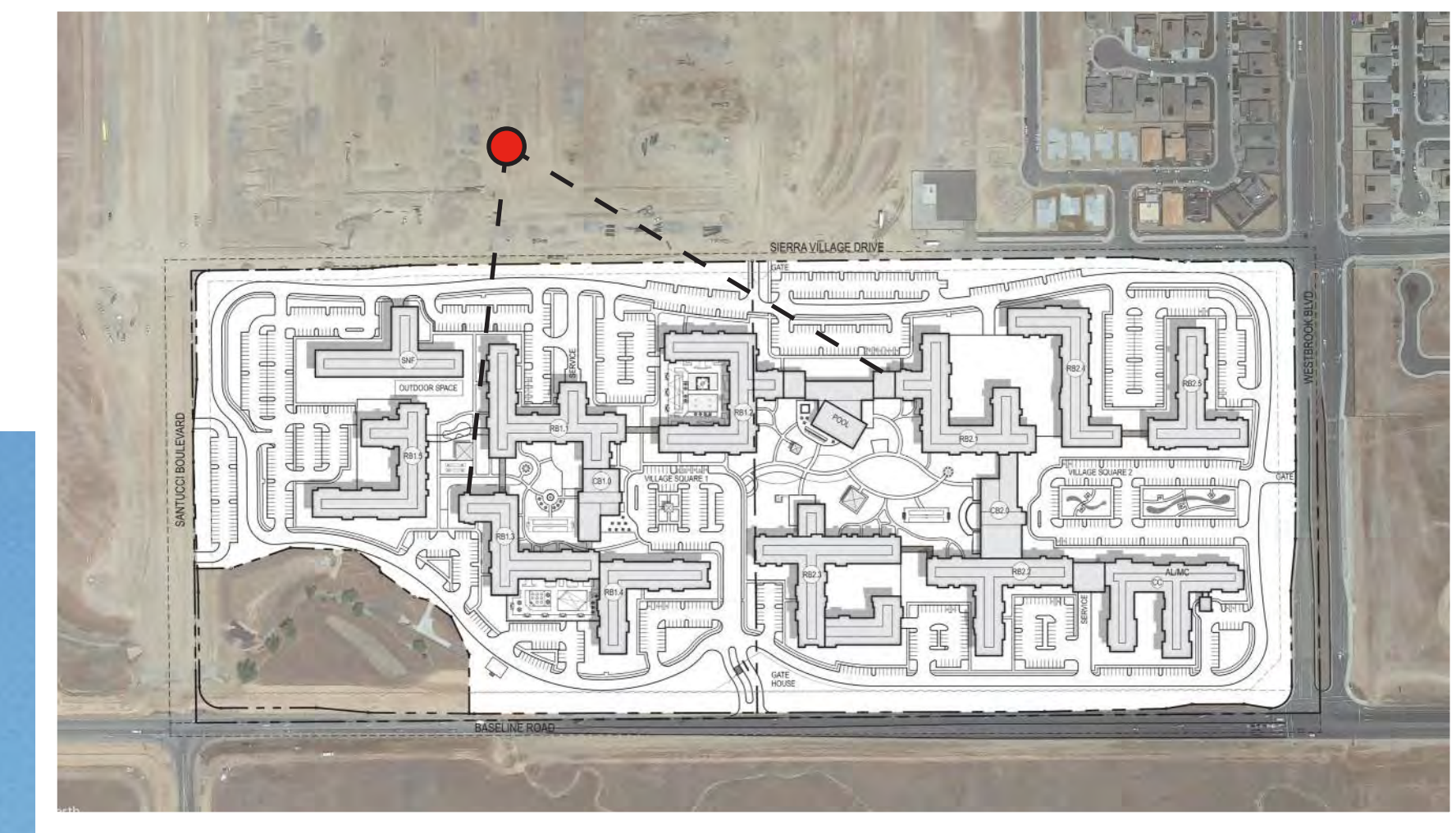

VIEW FROM HOLLOWTOP WAY NORTH OF SIERRA MORENA WAY

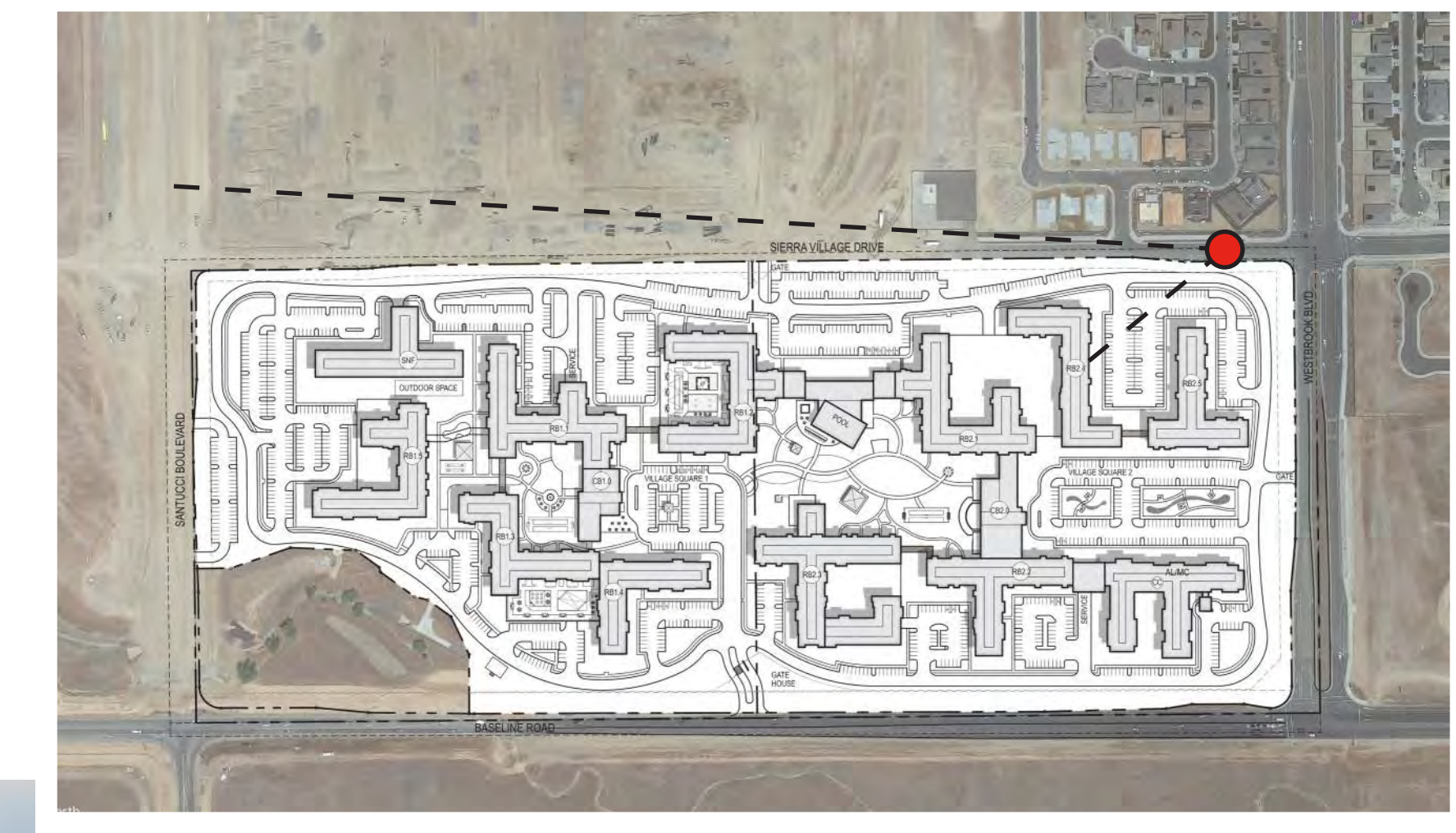

VIEW FROM SIERRA VILLAGE DRIVE

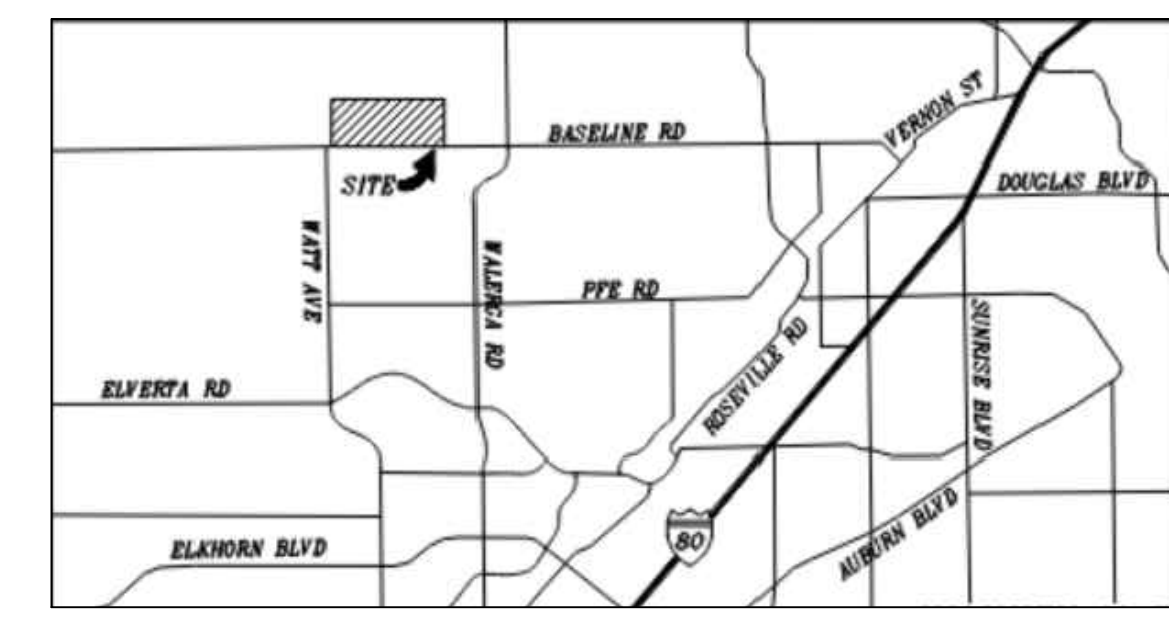

VICINITY MAP

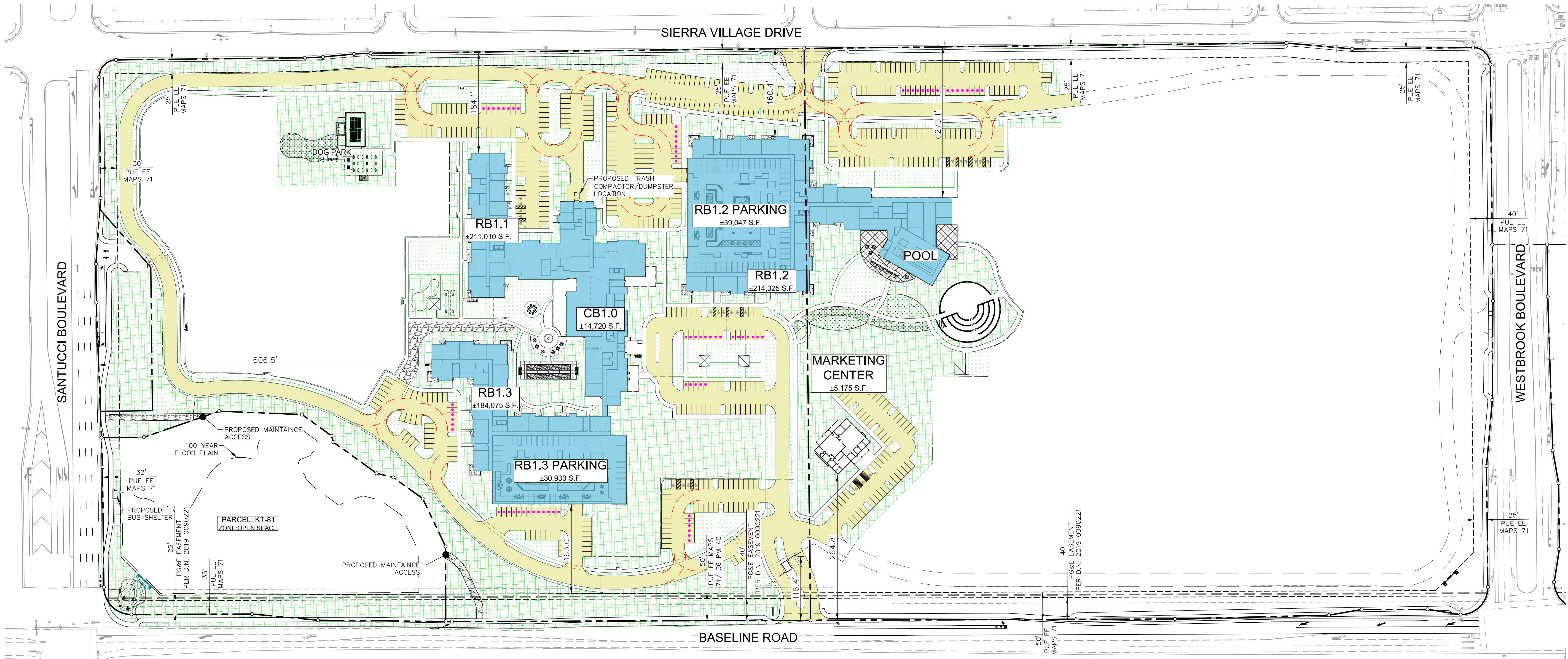
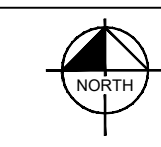

LEGEND

- ASPHALT PAVEMENT
- LANDSCAPE AREA
- CONCRETE SIDEWALK
- BUILDING AREA
- AMENDED SOILS AREA
- FIRE TRUCK RADIUS (TYP 30' & 50')

PROJECT SUMMARY

AREA
 AREA: 55.56± ACRES
 APN: 499-010-074-000, (LOT 1) (25.88 AC)
 APN: 499-010-075-000, (LOT 2) (29.68 AC)

SPECIFIC PLAN
 SIERRA VISTA SPECIFIC PLAN
 PARCELS KT-41A AND KT-41B

LAND USE DESIGNATION
 COMMUNITY COMMERCIAL (CC)

ZONING
 GENERAL COMMERCIAL (GC)

PROPOSED USES
 COMMUNITY CARE FACILITY,
 LONG-TERM CARE FACILITY,
 AND MEDICAL SERVICES

DEVELOPER
 ERICKSON SENIOR LIVING, LLC
 701 MAIDEN CHOICE LANE
 BALTIMORE, MD 21228
 ATTN: STEVEN MONTGOMERY

PROPERTY OWNER
 KV SIERRA VISTA, LLC
 7801 FOLSOM BOULEVARD
 SACRAMENTO, CA 95826

ENGINEER
 KIMLEY-HORN AND ASSOCIATES
 555 CAPITOL MALL SUITE 300
 SACRAMENTO, CA 95814
 ATTN: FAREED PITTALWALA

ARCHITECT
 LANTZ BOGGIO
 9550 DTC PARKWAY, SUITE 200
 ENGLEWOOD, CO 80111
 ATTN: DAVID FIK

BUILDING SUMMARY

BUILDING	STORIES	SQUARE FEET
RB 1.1	5	211,010
CB 1.0	1	14,720
RB 1.2	5	214,325
RB 1.3	6	184,075
MARKETING CENTER	1	5,175
SITE TOTALS:		629,305

PHASE 2	213
PHASE 3	112
PHASE 4	468
PHASE 5	245

CALGREEN REQUIREMENTS
 ELECTRIC VEHICLE CHARGING CAPABLE (10% OF 774) ● 77

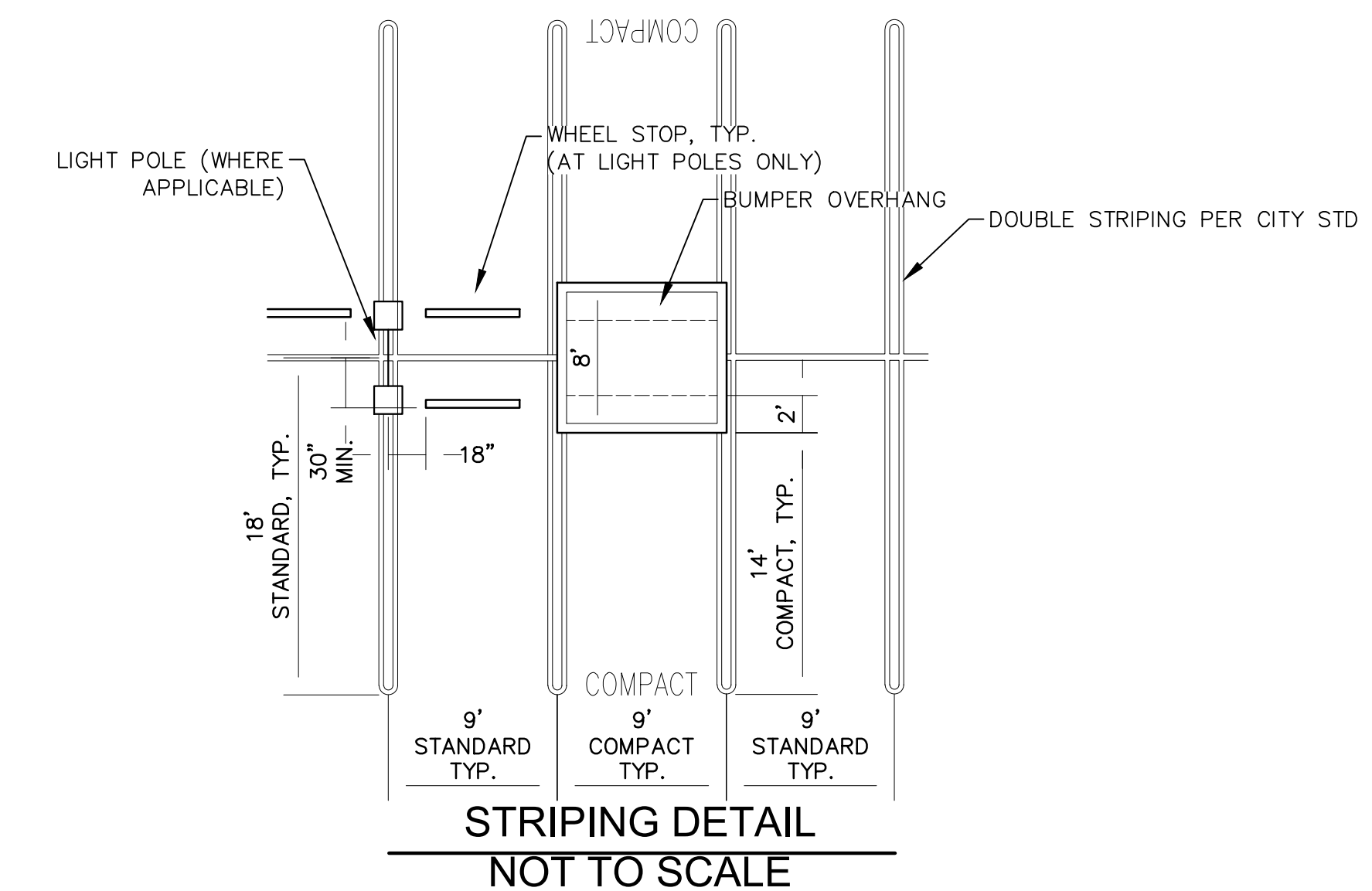

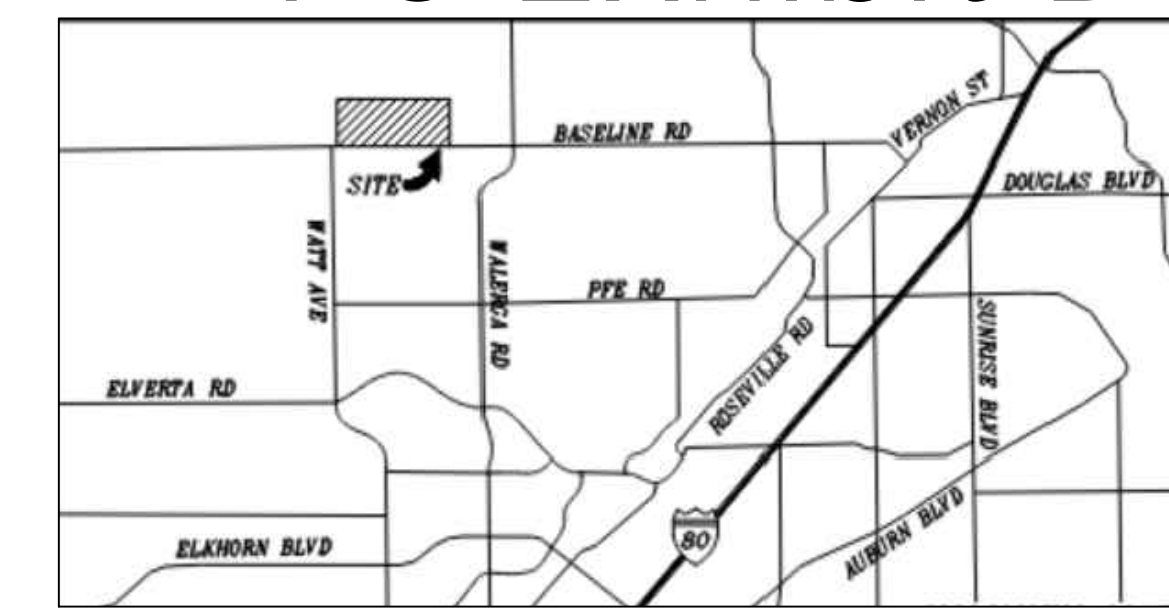





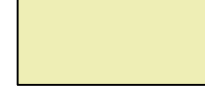

VICINITY MAP

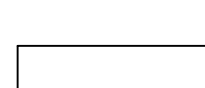

LEGEND

-  ASPHALT PAVEMENT
-  LANDSCAPE AREA
-  CONCRETE SIDEWALK
-  BUILDING AREA
-  AMENDED SOILS AREA
-  FIRE TRUCK RADIUS (TYP 30' & 50')

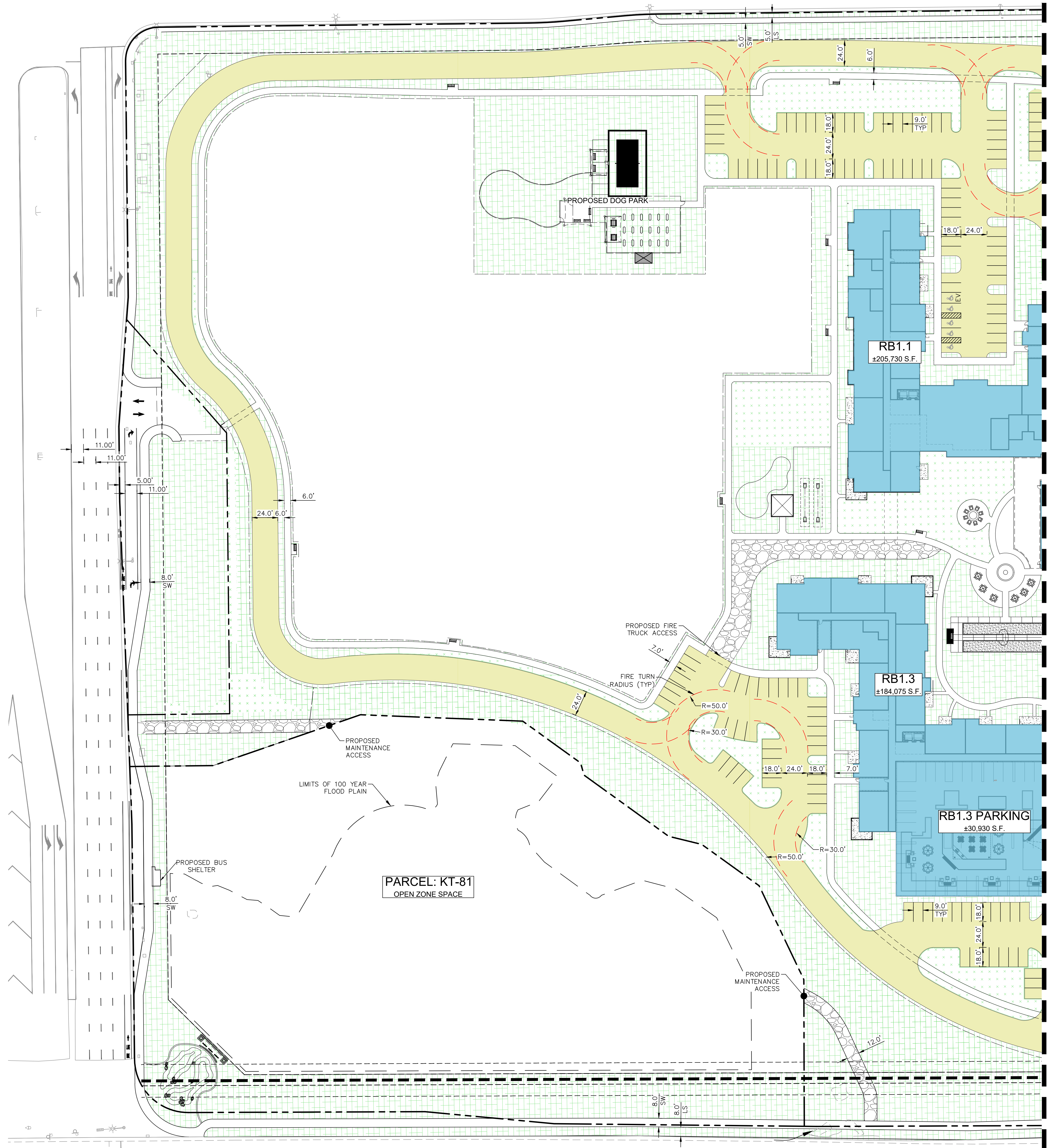

MATCHLINE - SEE SHEET SITE PLAN - EAST

PARCEL: KT-81
OPEN ZONE SPACE

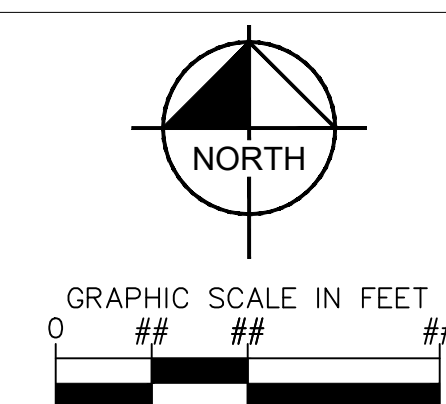

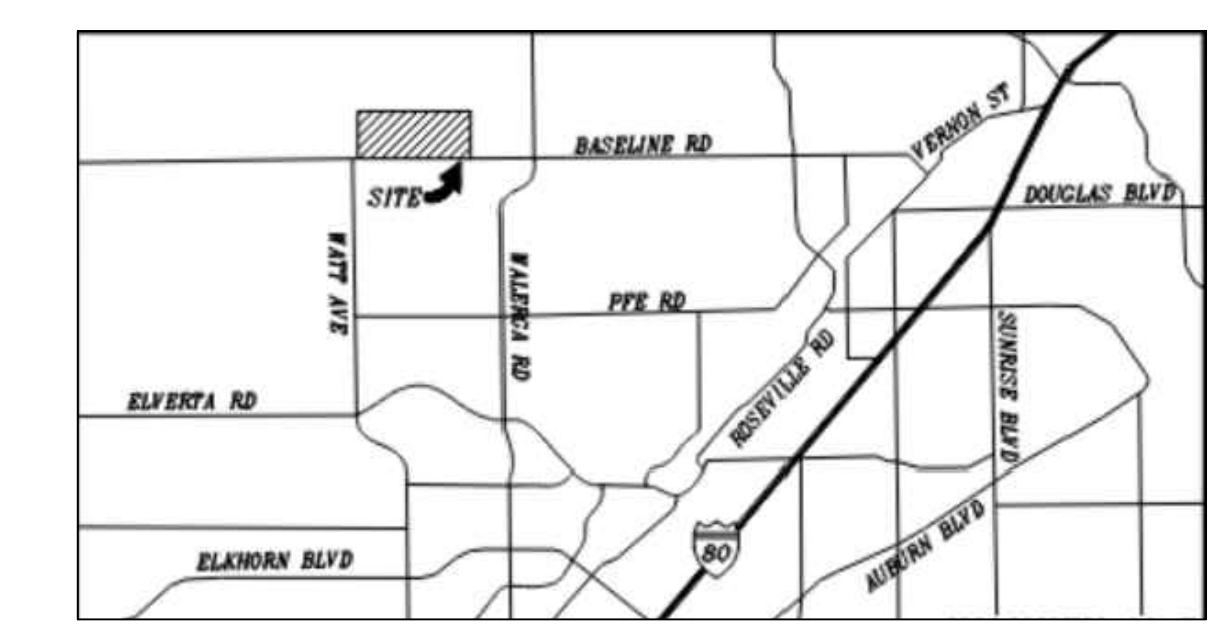

VICINITY MAP

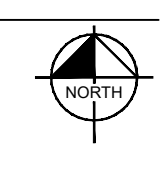

LEGEND

- ASPHALT PAVEMENT
- LANDSCAPE AREA
- CONCRETE SIDEWALK
- BUILDING AREA
- FIRE TRUCK RADIUS (TYP 30' & 50')

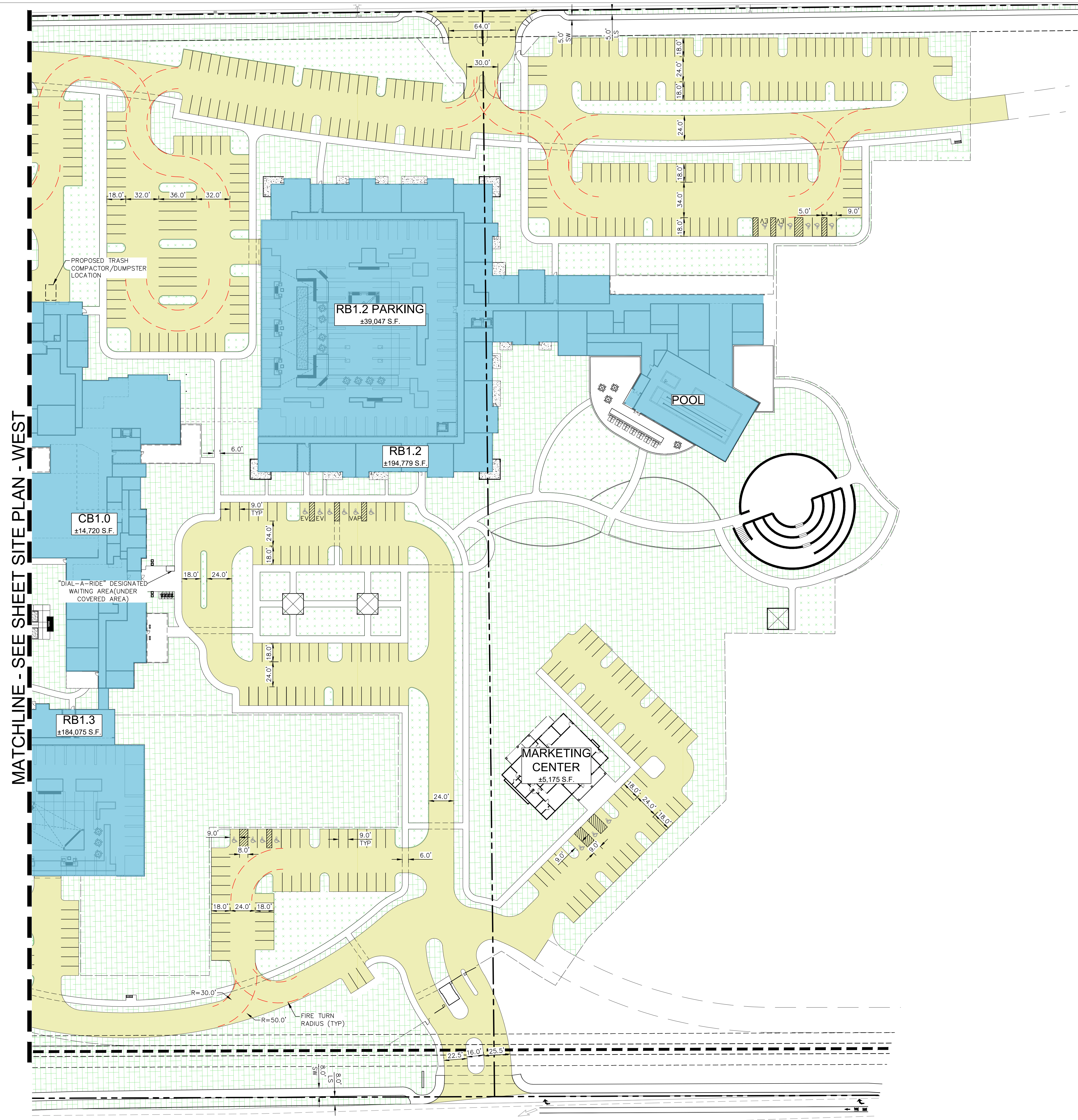

MATCHLINE - SEE SHEET SITE PLAN - WEST

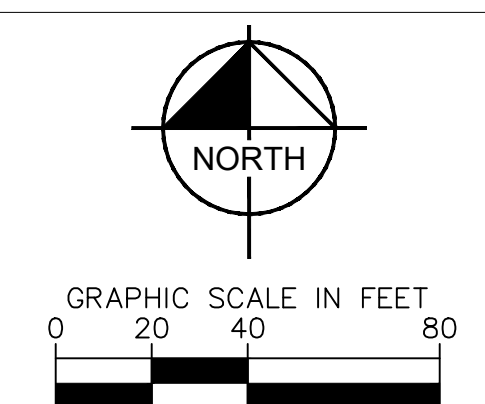



O1 / SOUTH ELEVATION
1/8" = 1'



O2 / EAST ELEVATION
1/8" = 1'



O3 / SOUTH ELEVATION
1/8" = 1'

EXTERIOR ELEVATIONS - RB1.2

ERICKSON SENIOR LIVING ROSEVILLE

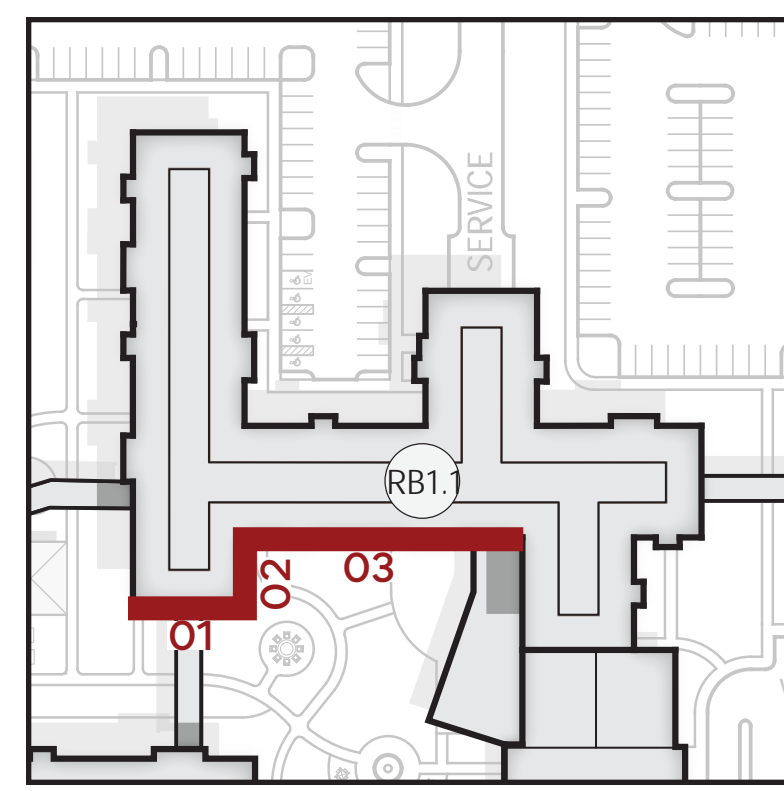

01 / RB1.1 SOUTH ELEVATION 01
SCALE: 1/8" = 1'



02 / RB1.1 EAST ELEVATION 01
SCALE: 1/8" = 1'

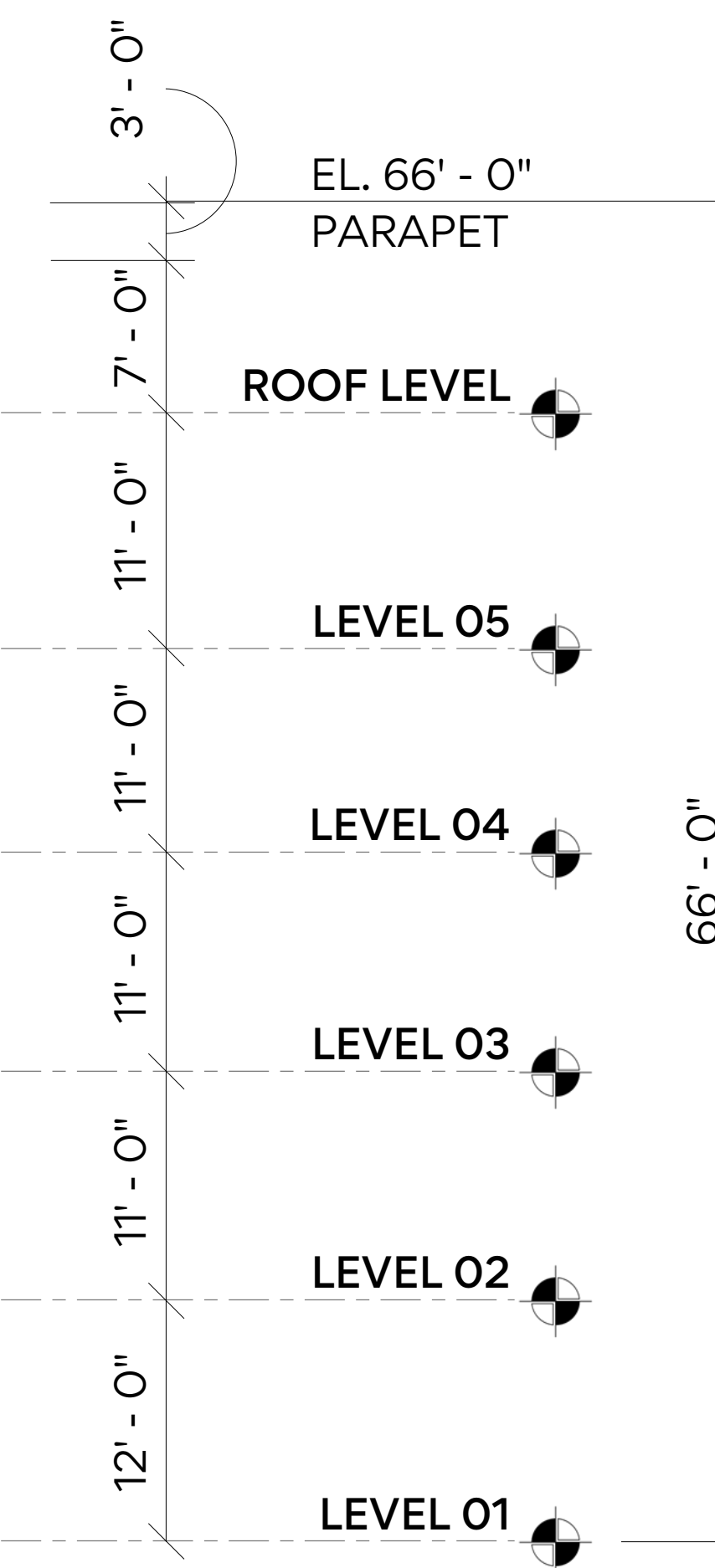

03 / RB1.1 SOUTH ELEVATION 02
SCALE: 1/8" = 1'

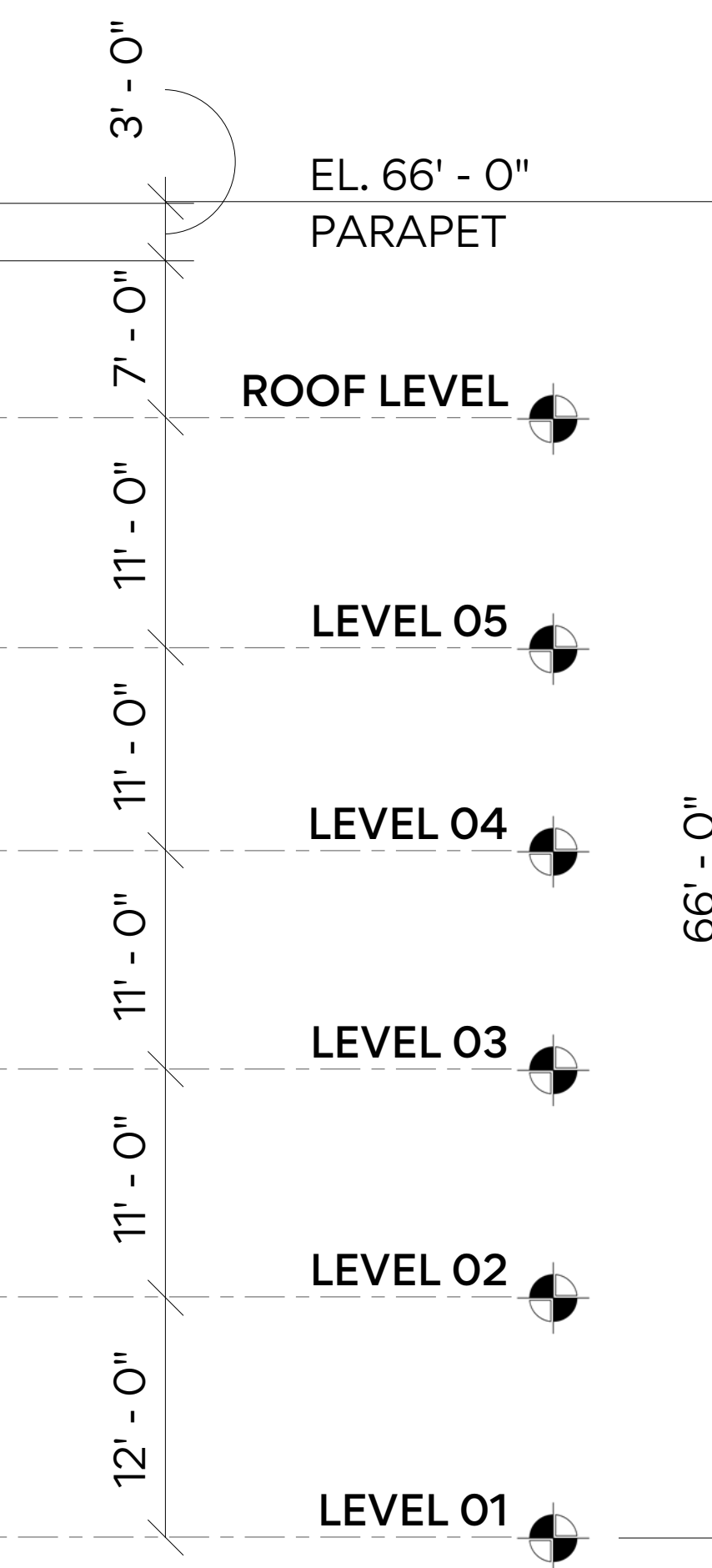

EXTERIOR ELEVATIONS - RB1.1

ERICKSON SENIOR LIVING - WEST ROSEVILLE

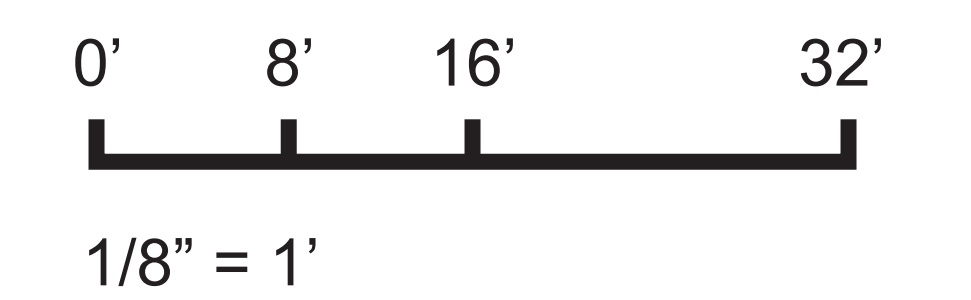

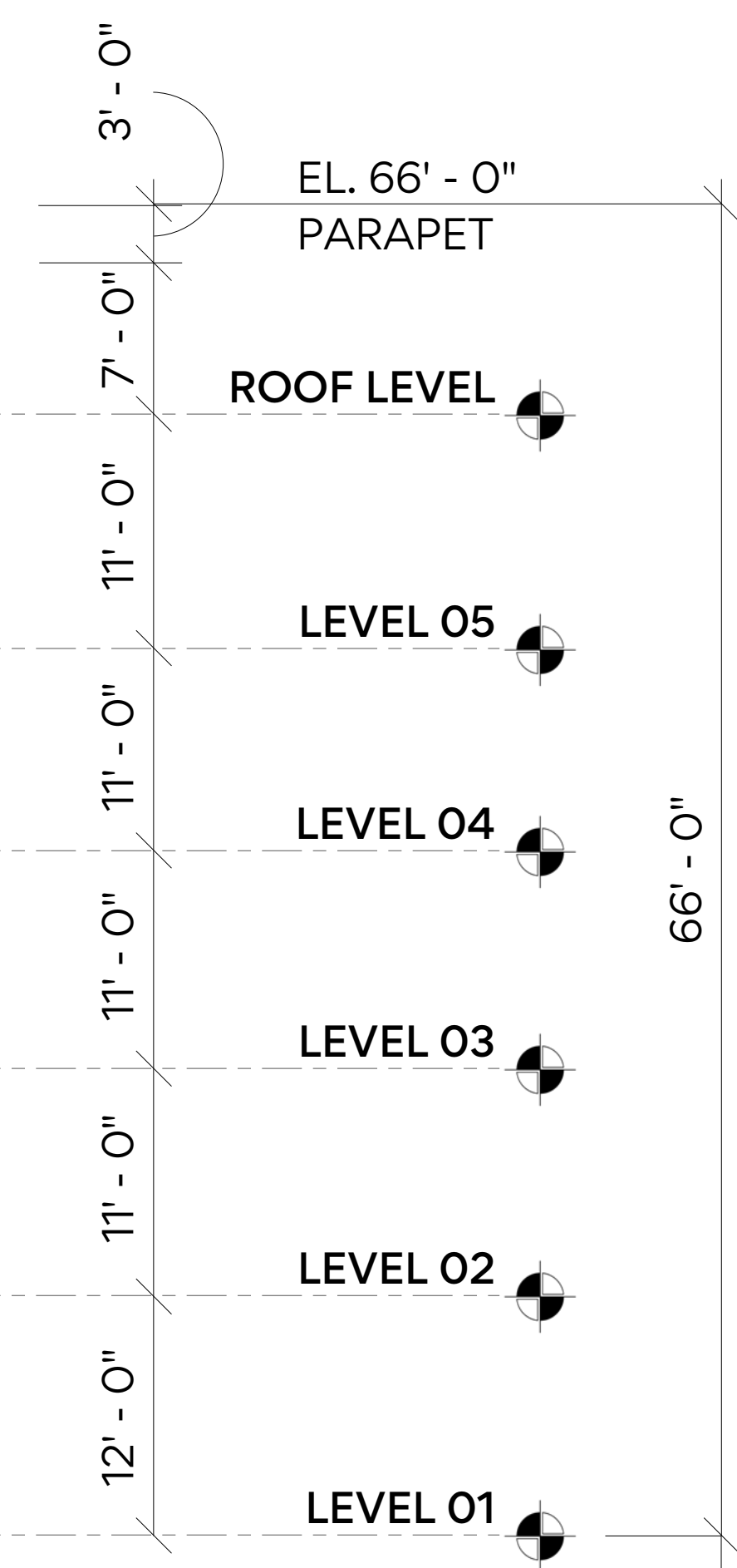
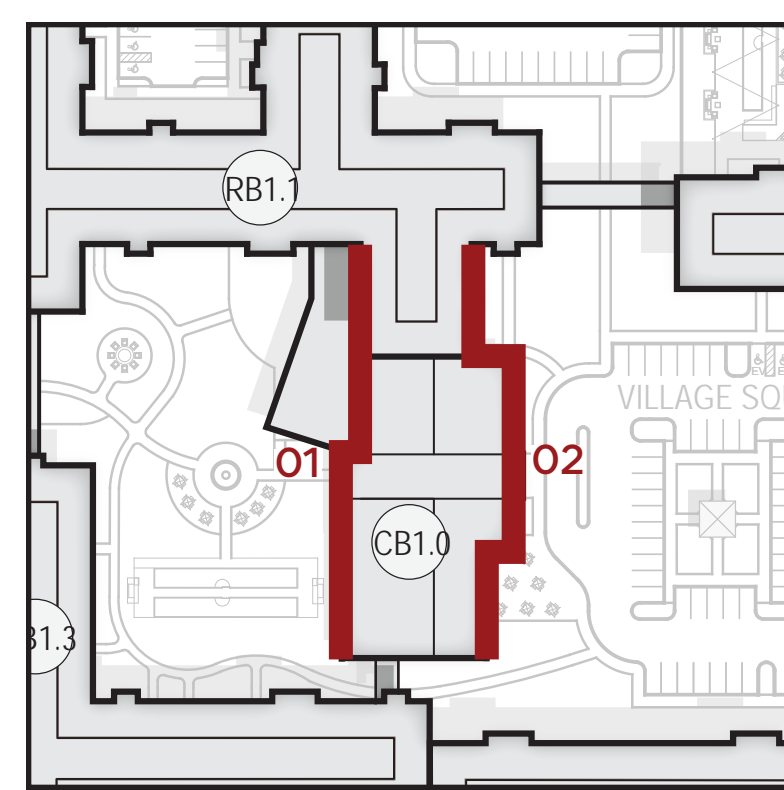

01 / CB1.0 & RB1.1 - WEST ELEVATION
SCALE: 1/8" = 1'

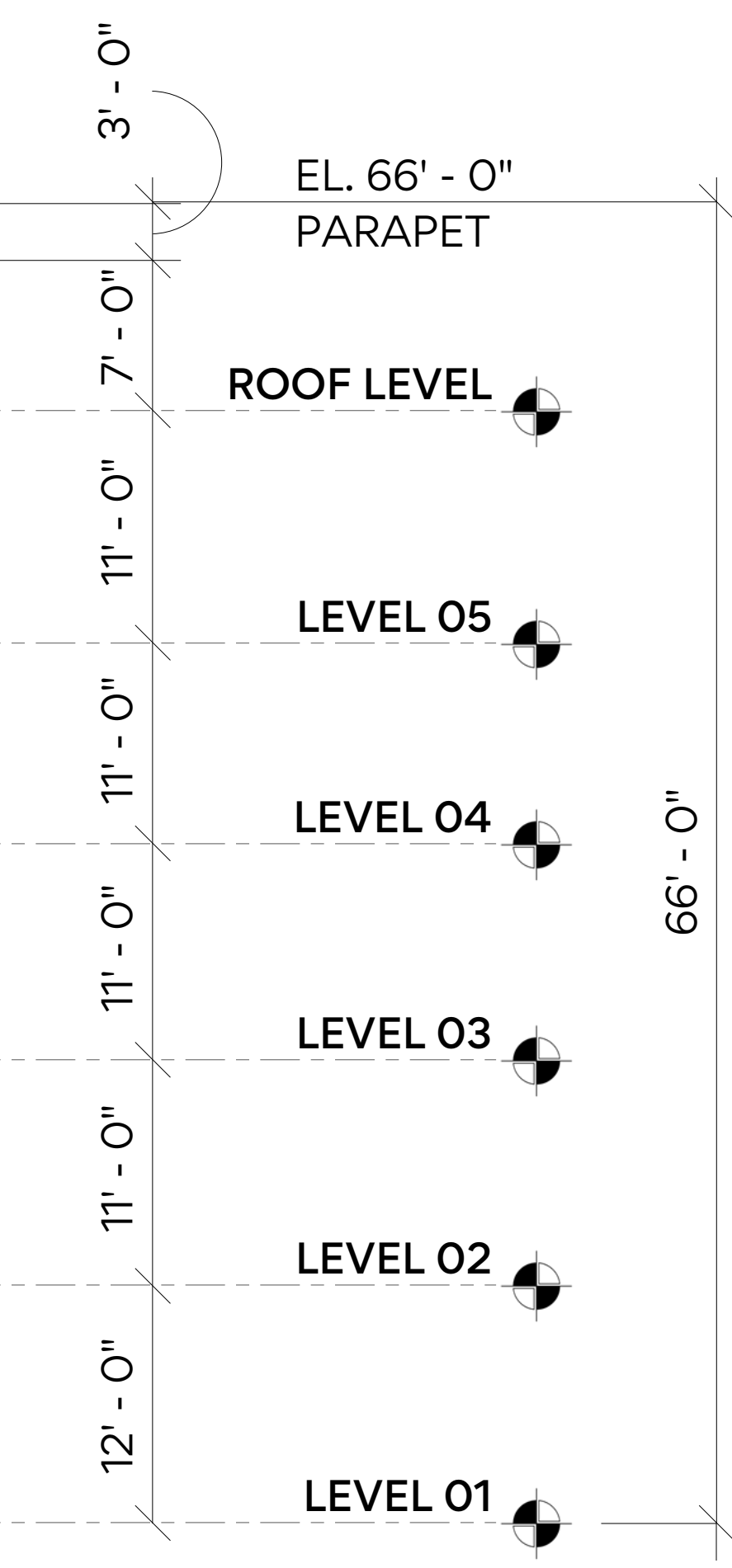

02 / CB1.0 & RB1.1 - EAST ELEVATION
SCALE: 1/8" = 1'

EXTERIOR ELEVATIONS - RB1.1

ERICKSON SENIOR LIVING - WEST ROSEVILLE

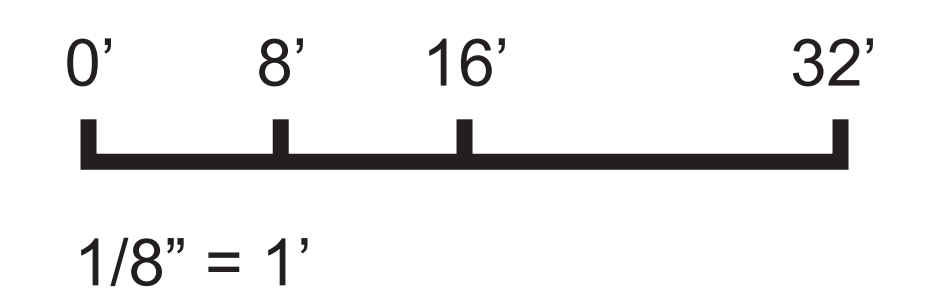

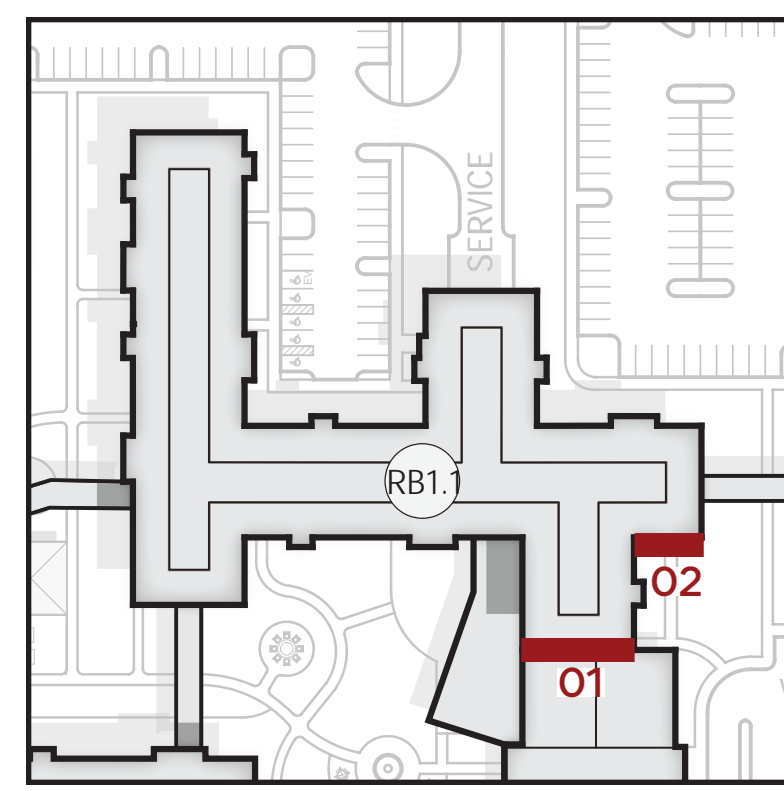

01 / RB1.1 - SOUTH ELEVATION 03
SCALE: 1/8" = 1'



02 / RB1.1 - SOUTH ELEVATION 04
SCALE: 1/8" = 1'

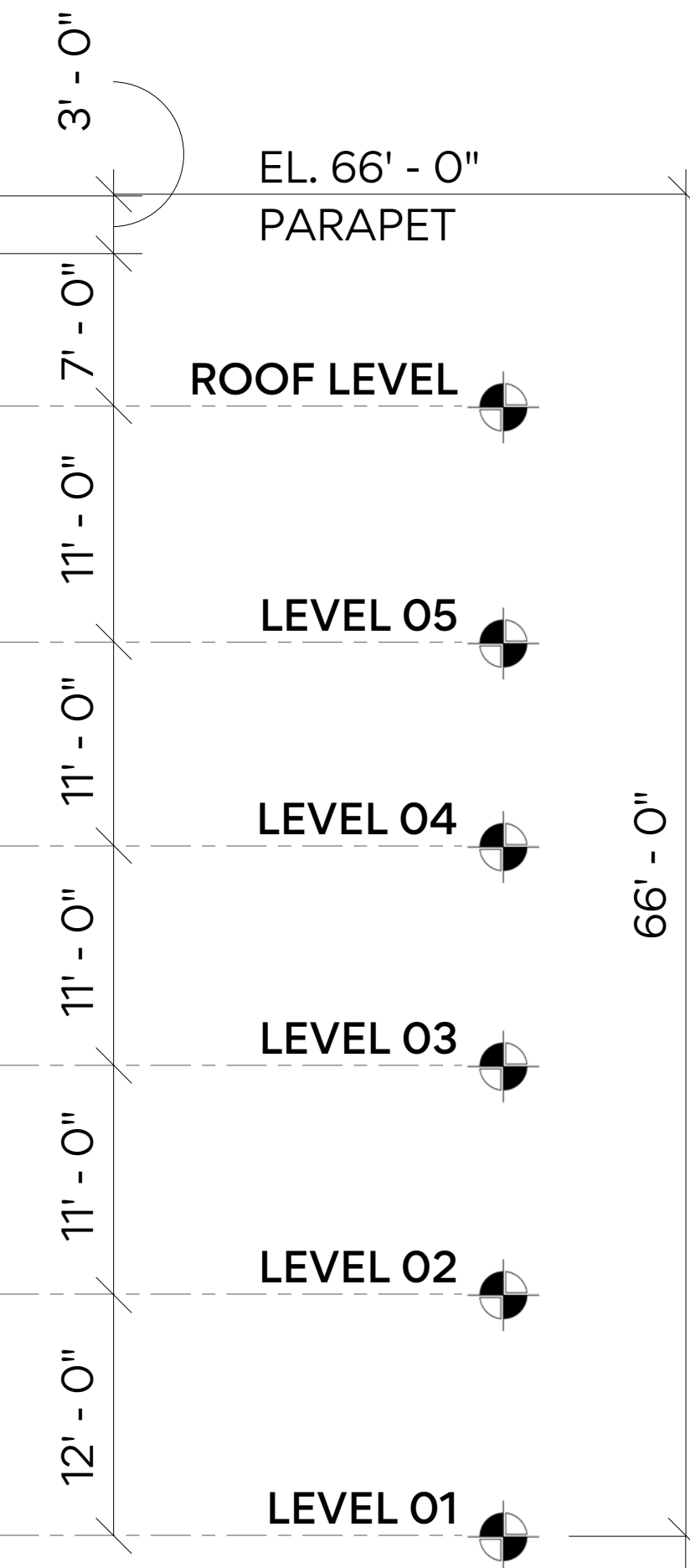

EXTERIOR ELEVATIONS - RB1.1

ERICKSON SENIOR LIVING - WEST ROSEVILLE

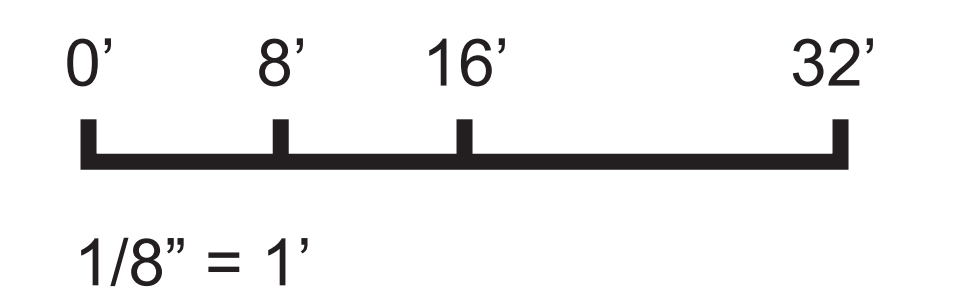

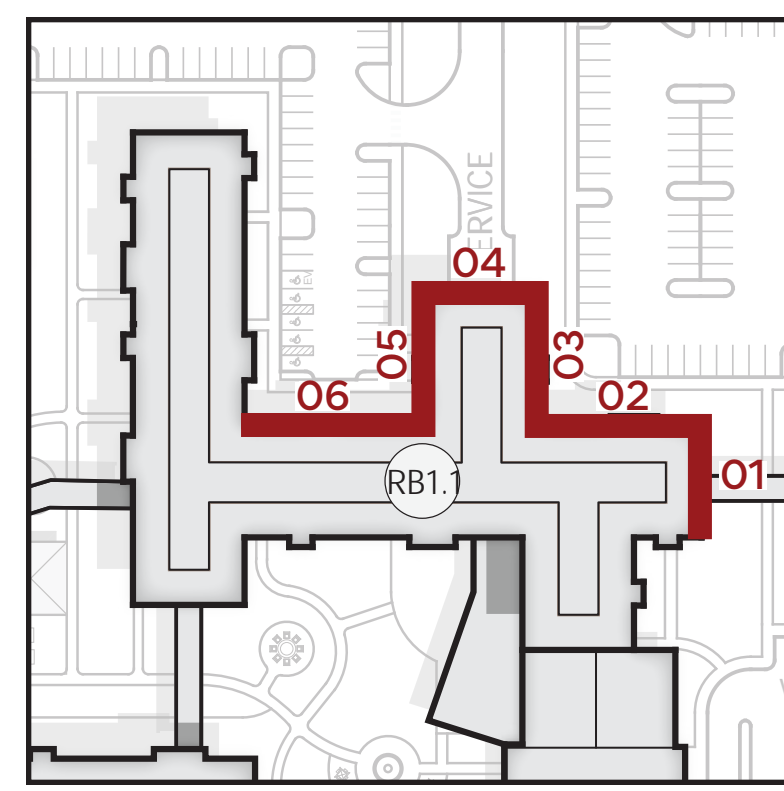

01 / RB1.1 - EAST ELEVATION 02
SCALE: 1/8" = 1'



02 / RB1.1 - NORTH ELEVATION 01
SCALE: 1/8" = 1'



03 / RB1.1 - EAST ELEVATION 03
SCALE: 1/8" = 1'

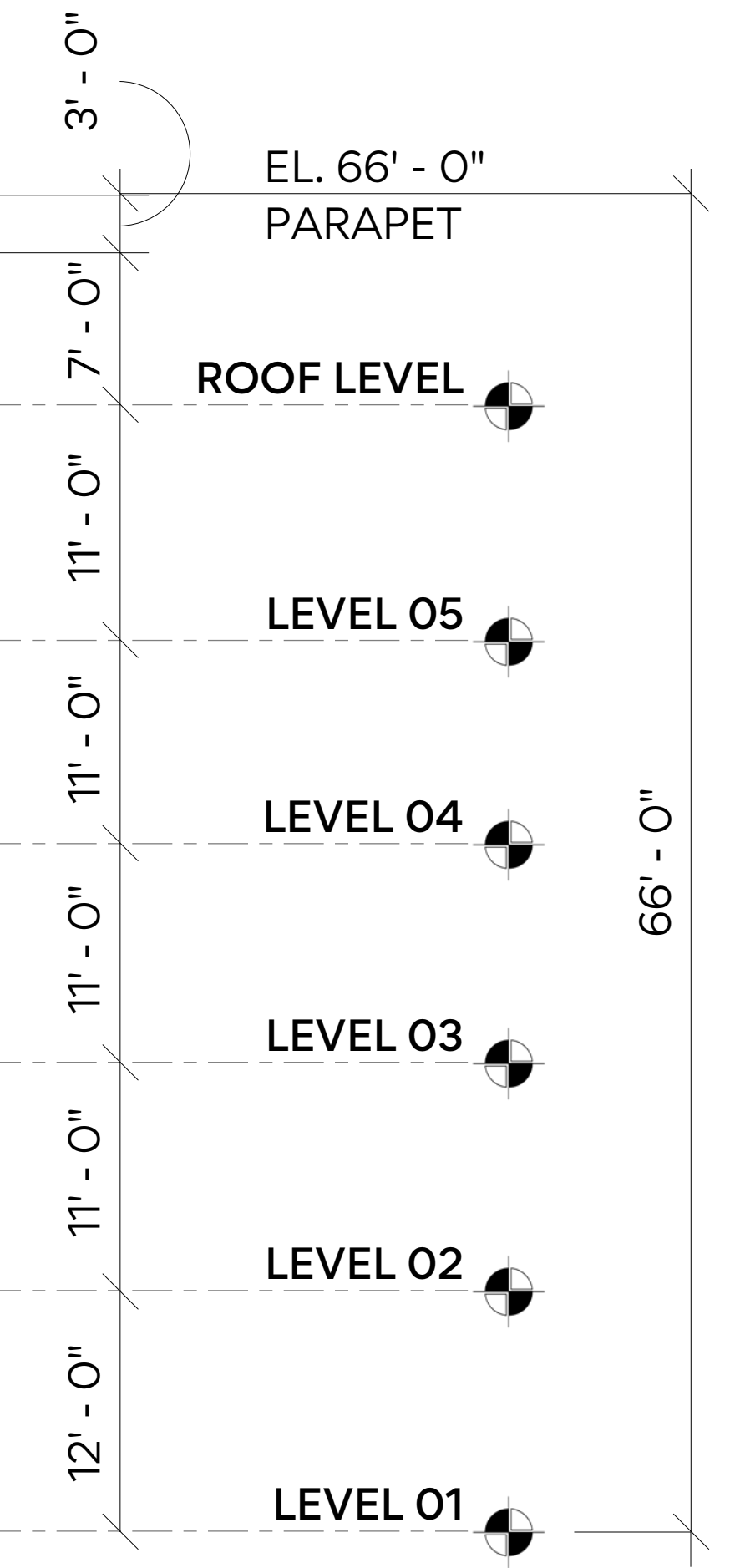

04 / RB1.1 - NORTH ELEVATION 02
SCALE: 1/8" = 1'



05 / RB1.1 - WEST ELEVATION 02
SCALE: 1/8" = 1'



06 / RB1.1 - NORTH ELEVATION 03
SCALE: 1/8" = 1'

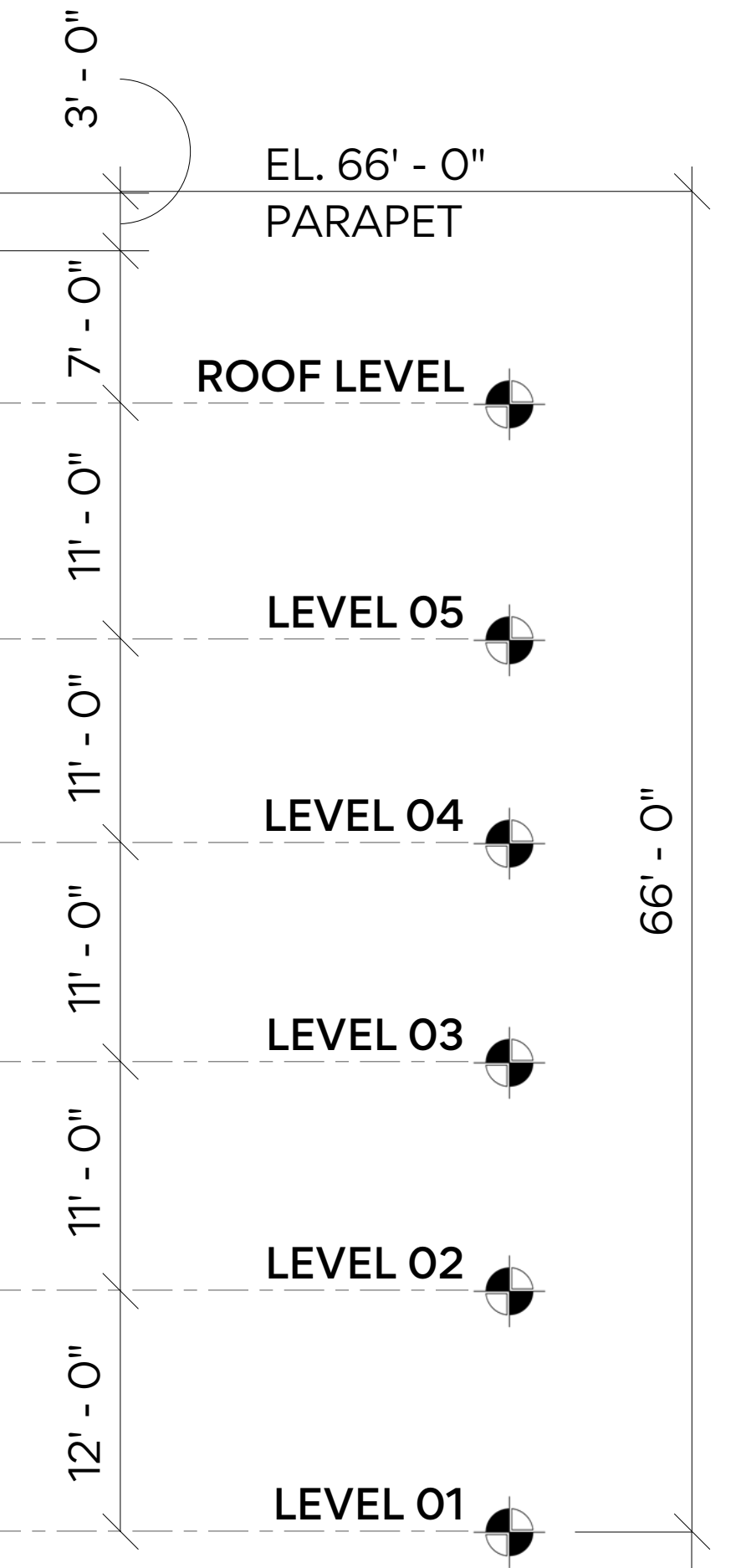

EXTERIOR ELEVATIONS - RB1.1

ERICKSON SENIOR LIVING - WEST ROSEVILLE

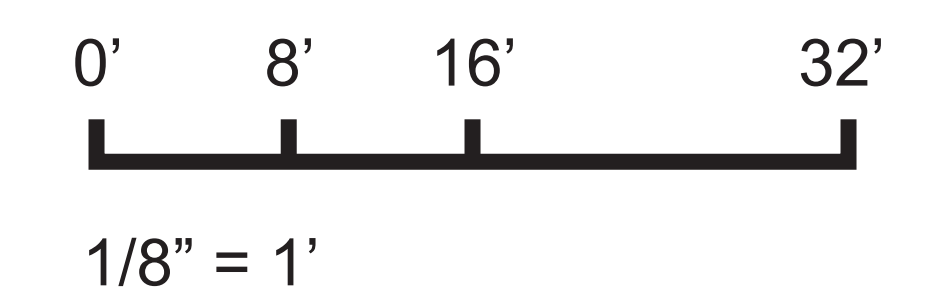

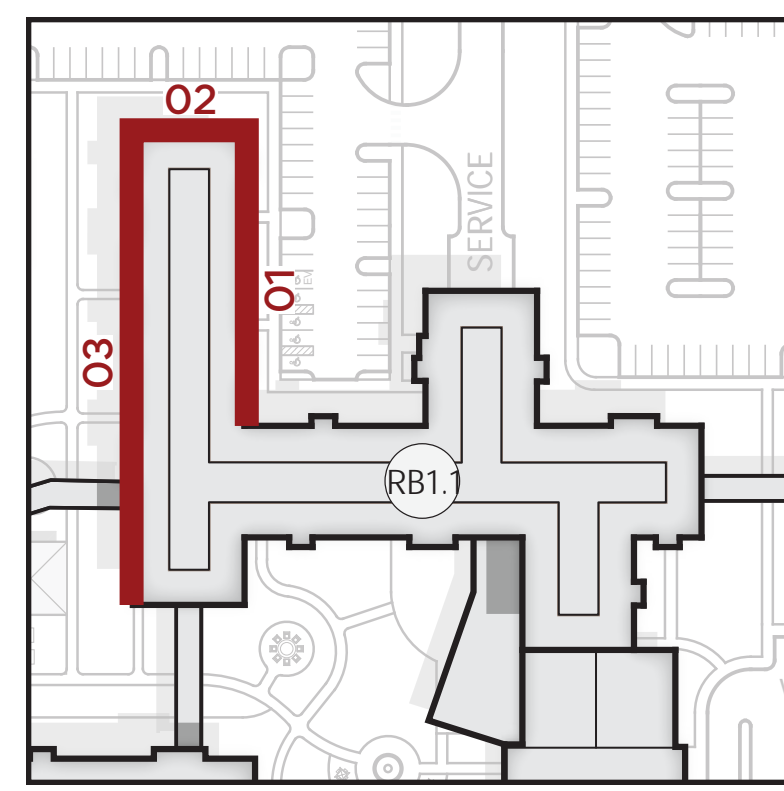

01 / RB1.1 - EAST ELEVATION 04
SCALE: 1/8" = 1'



02 / RB1.1 - EAST ELEVATION 04
SCALE: 1/8" = 1'

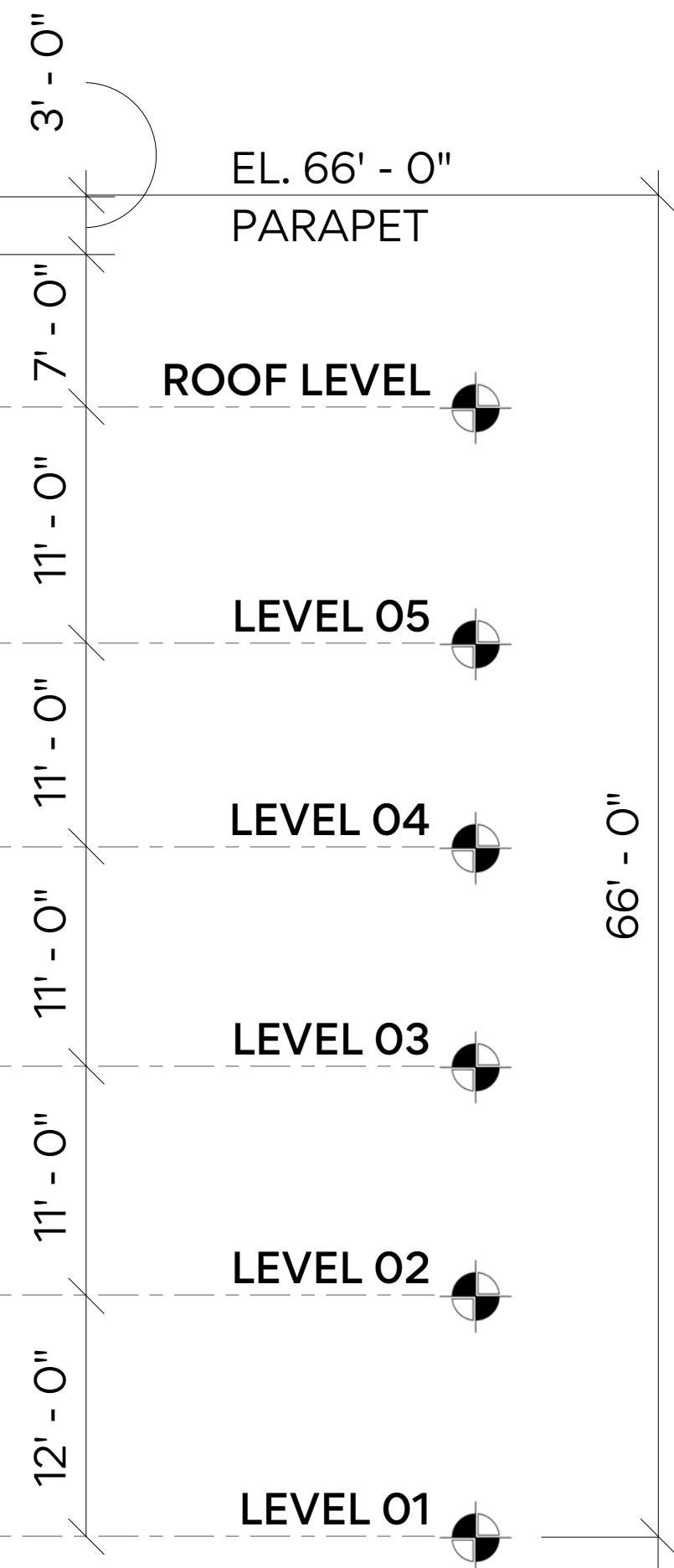

03 / RB1.1 - WEST ELEVATION 04
SCALE: 1/8" = 1'

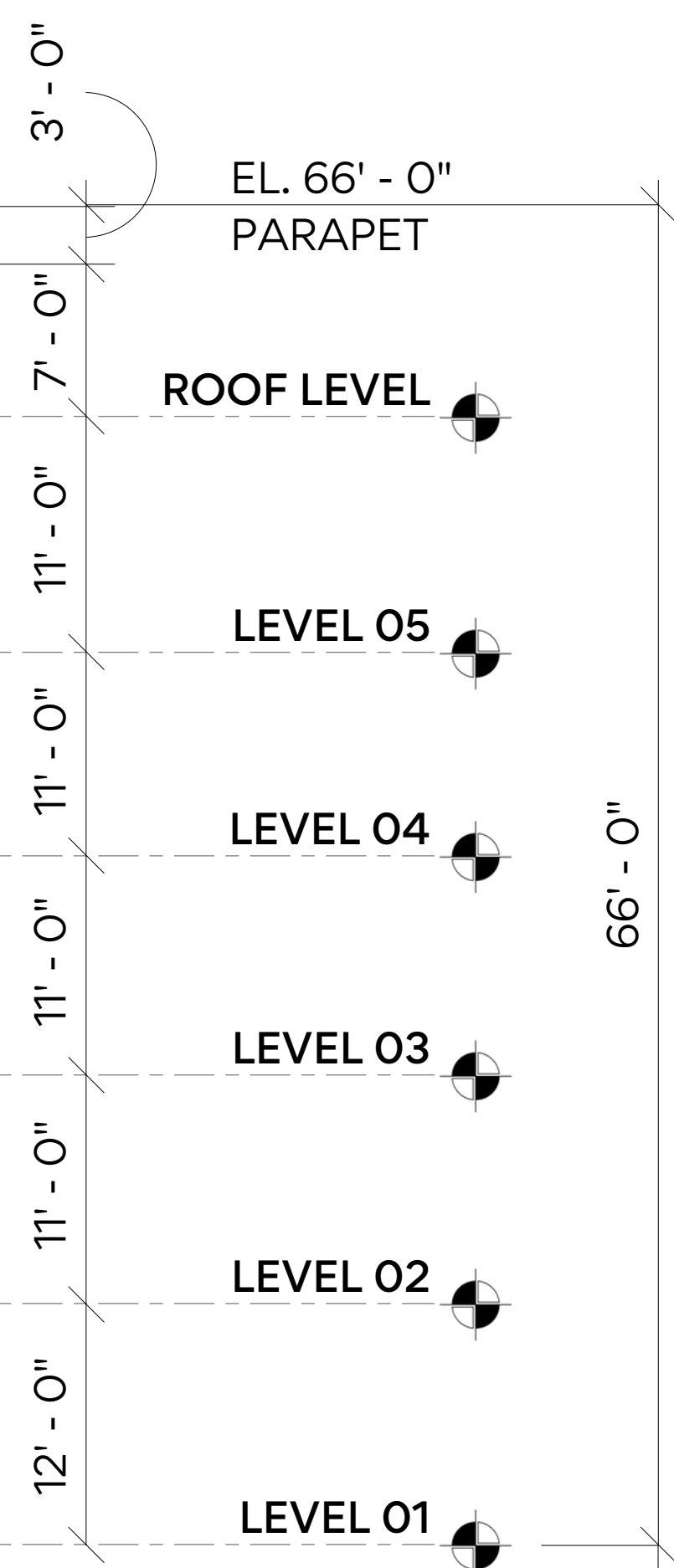

EXTERIOR ELEVATIONS - RB1.1

ERICKSON SENIOR LIVING - WEST ROSEVILLE

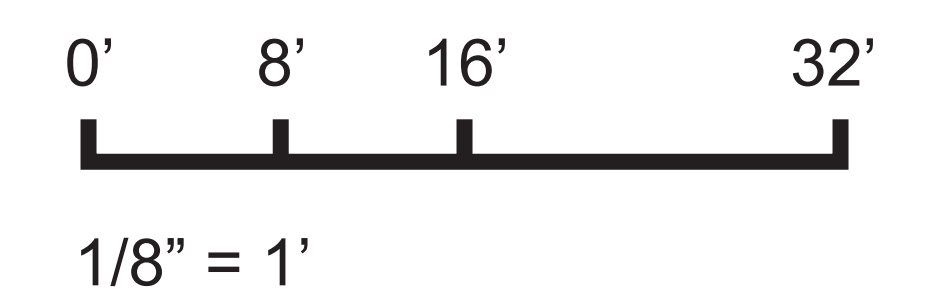

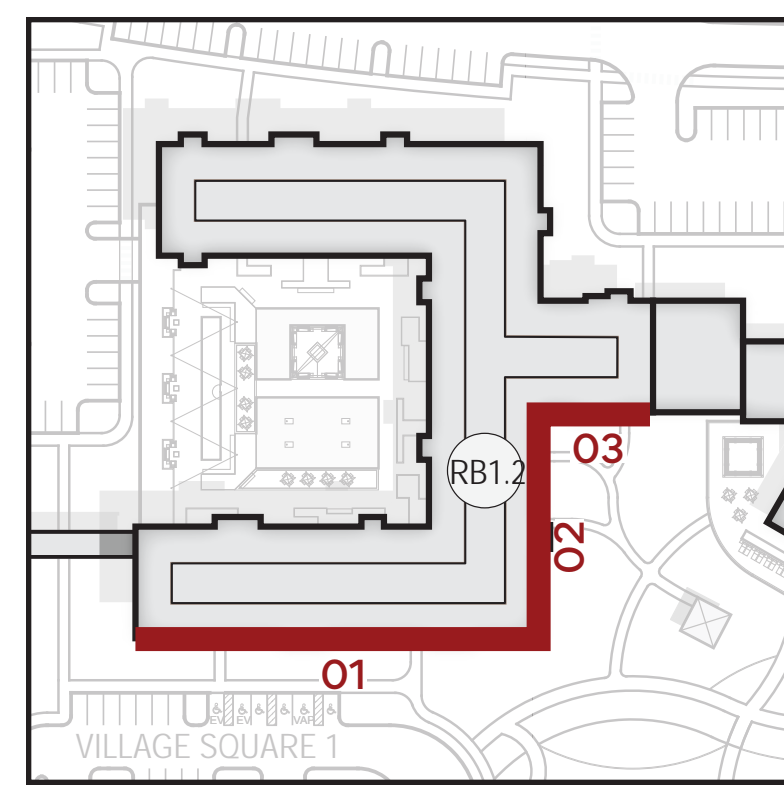

01 / RB1.2 - SOUTH ELEVATION 01
SCALE: 1/8" = 1'



03 / RB1.2 - EAST ELEVATION 01
SCALE: 1/8" = 1'

02 / RB1.2 - SOUTH ELEVATION 02
SCALE: 1/8" = 1'

EXTERIOR ELEVATIONS - RB1.2

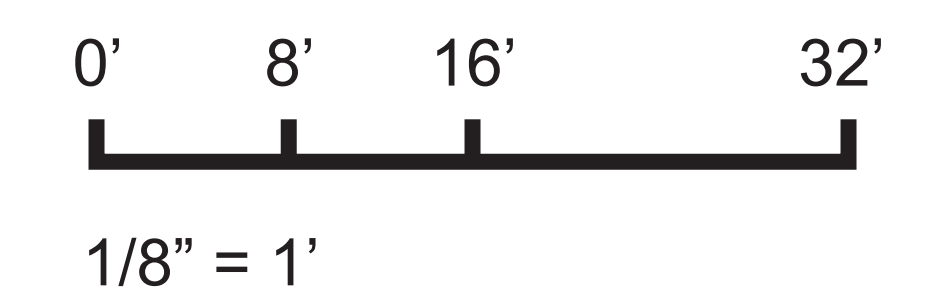

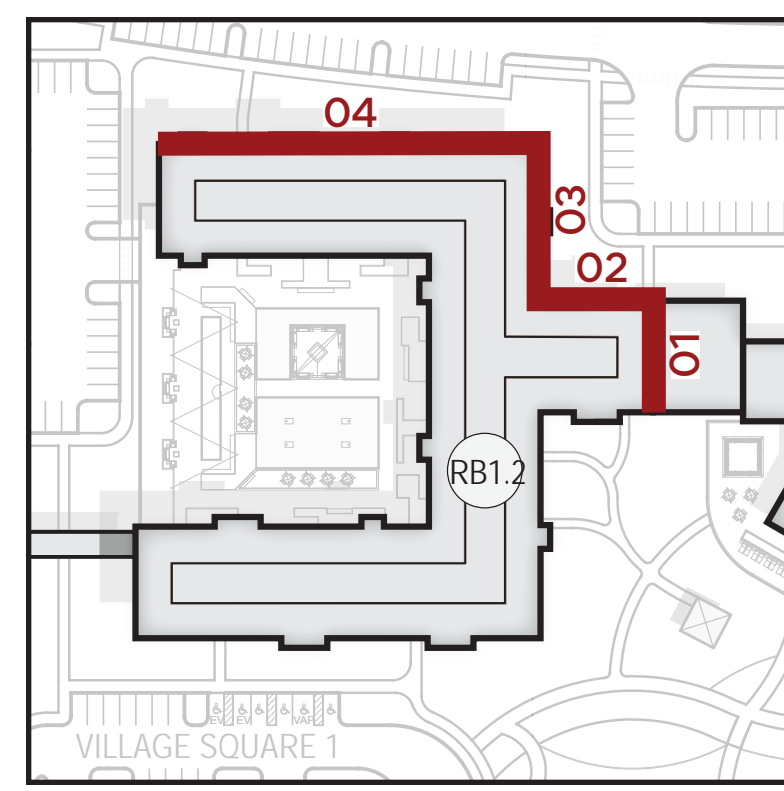

01 / RB1.2 - EAST ELEVATION 02
SCALE: 1/8" = 1'



02 / RB1.2 - NORTH ELEVATION 01
SCALE: 1/8" = 1'



03 / RB1.2 - EAST ELEVATION 03
SCALE: 1/8" = 1'

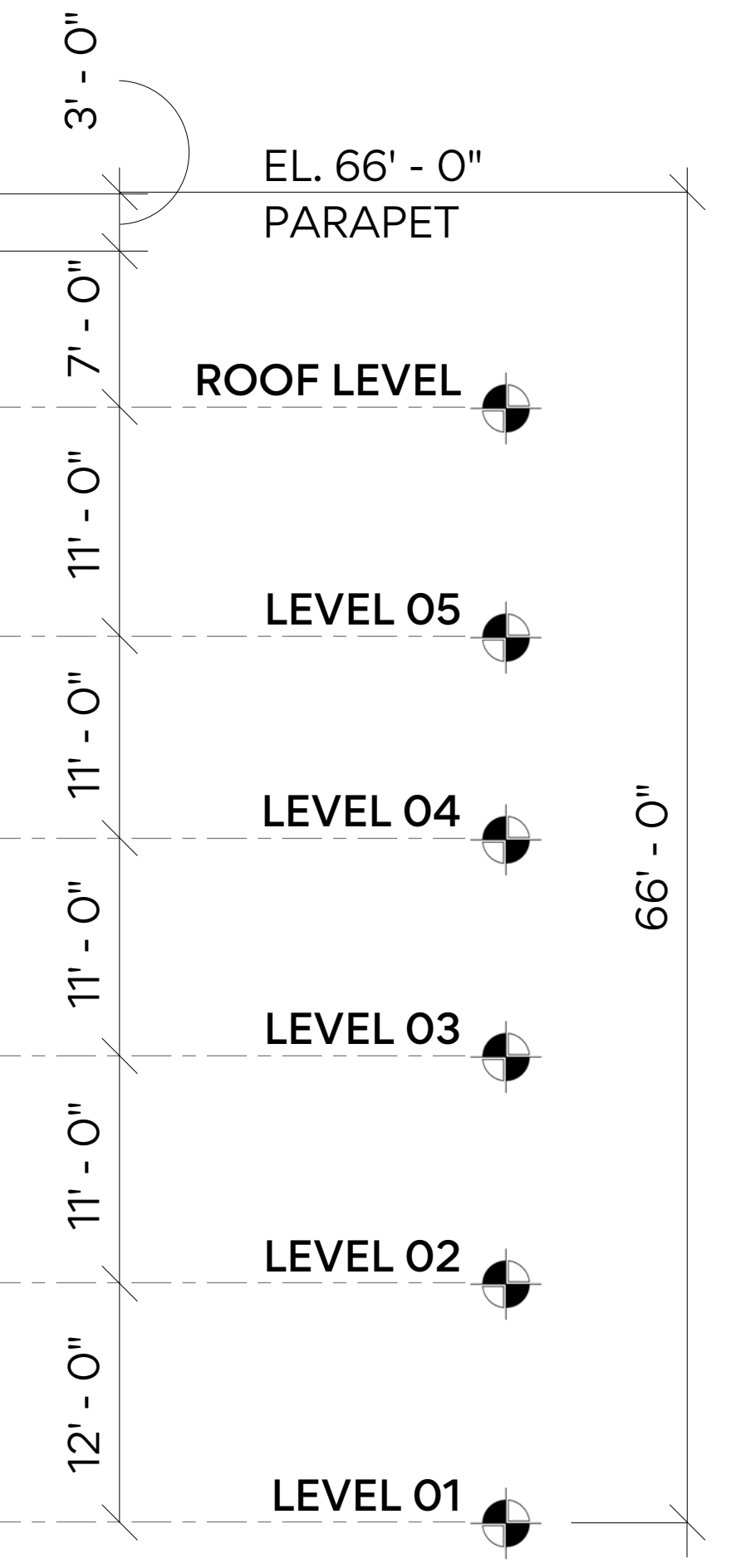

04 / RB1.2 - NORTH ELEVATION 02
SCALE: 1/8" = 1'

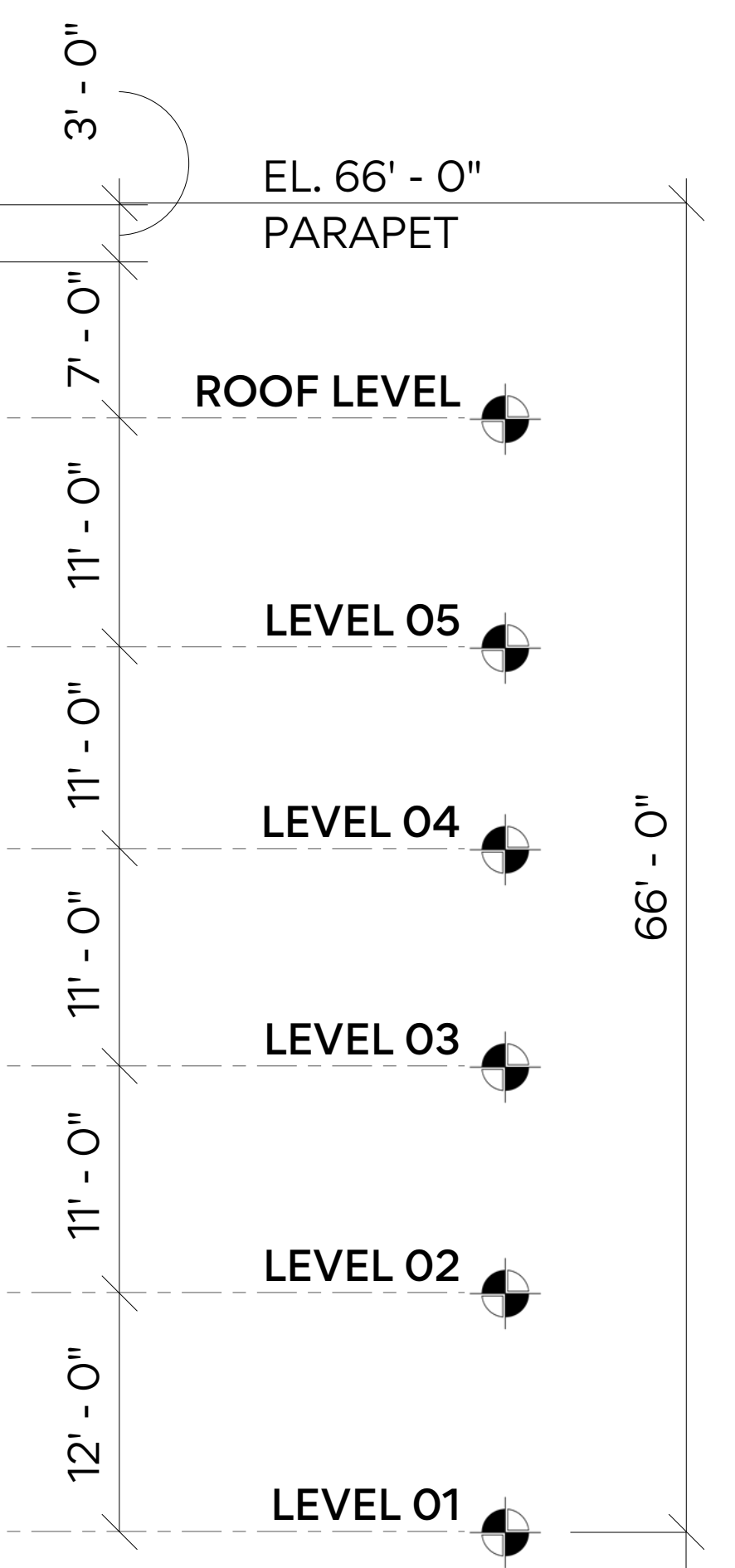

EXTERIOR ELEVATIONS - RB1.2

ERICKSON SENIOR LIVING - WEST ROSEVILLE

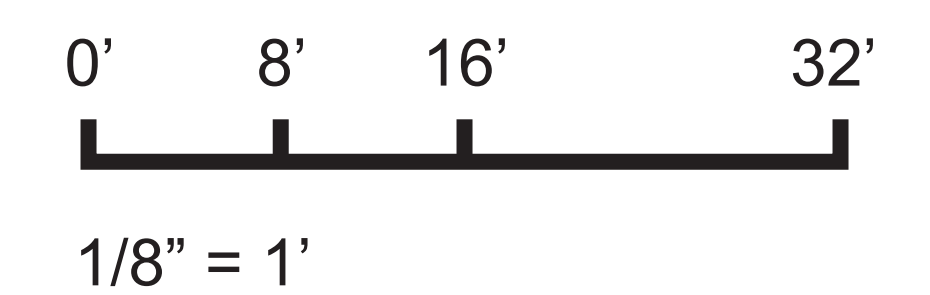

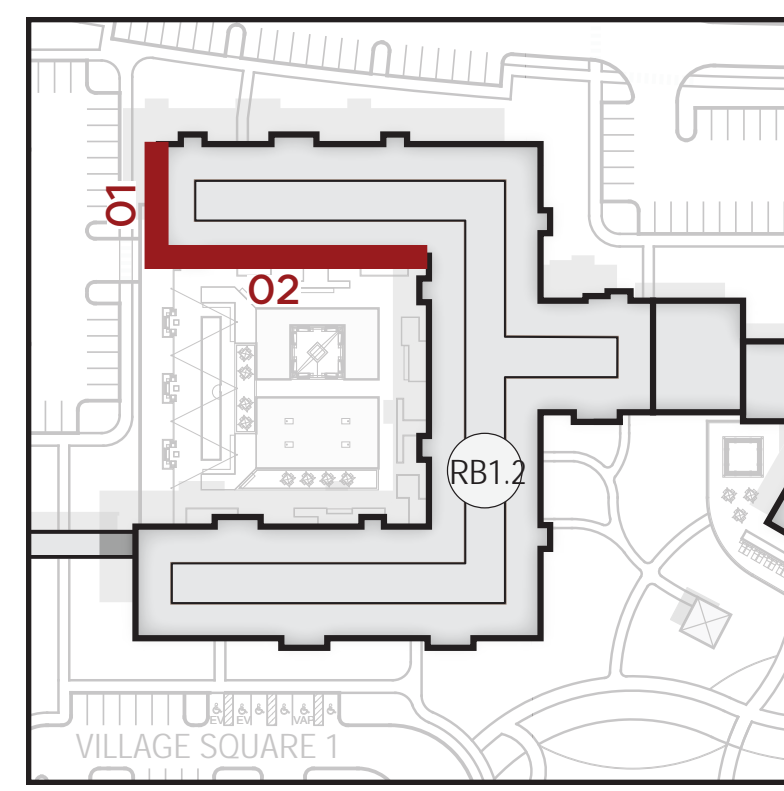

01 / RB1.2 - WEST ELEVATION 01
SCALE: 1/8" = 1'

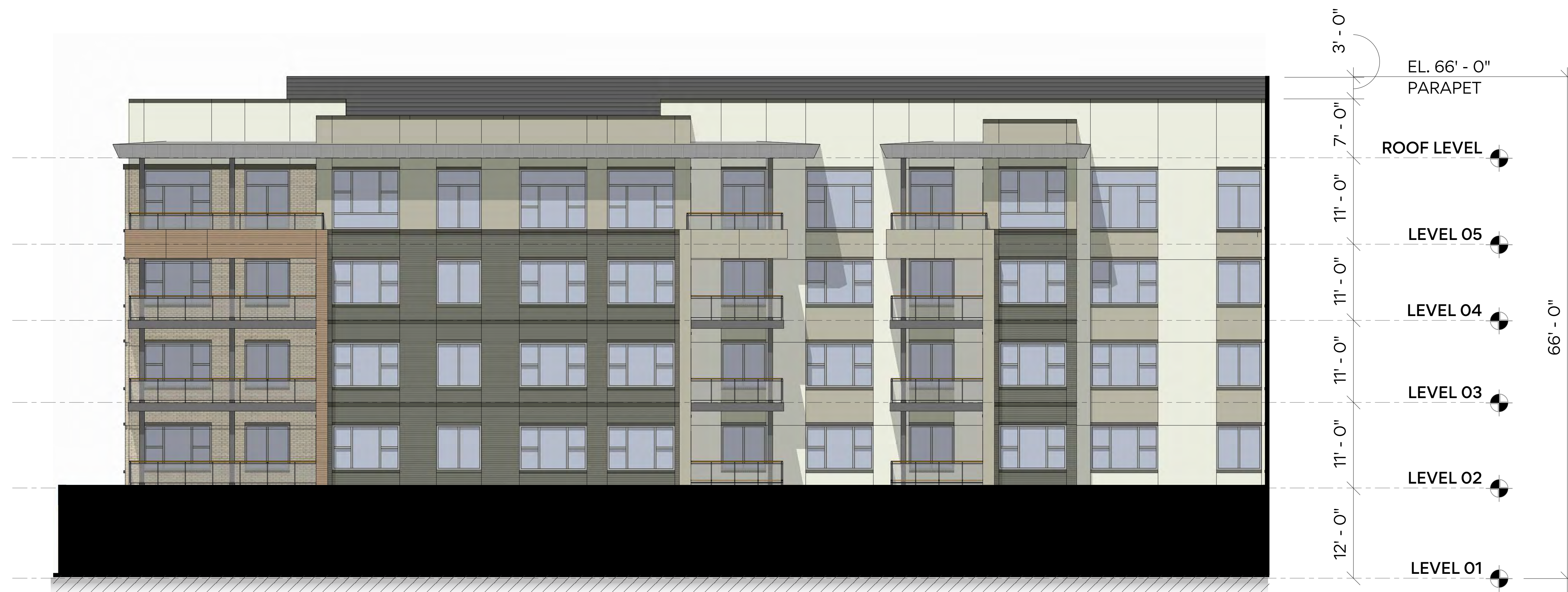

02 / RB1.2 - SOUTH ELEVATION 03
SCALE: 1/8" = 1'

EXTERIOR ELEVATIONS - RB1.2

ERICKSON SENIOR LIVING - WEST ROSEVILLE

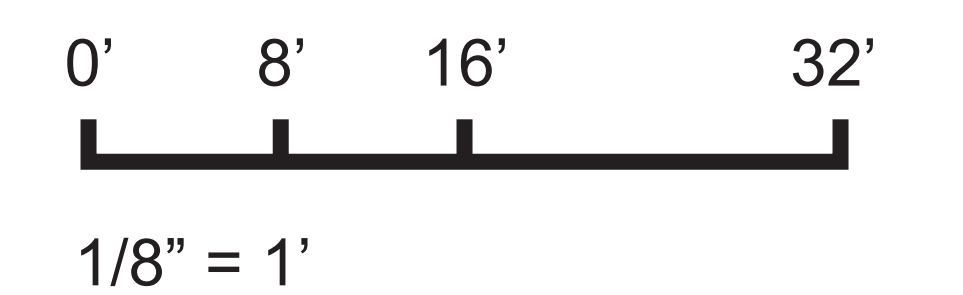

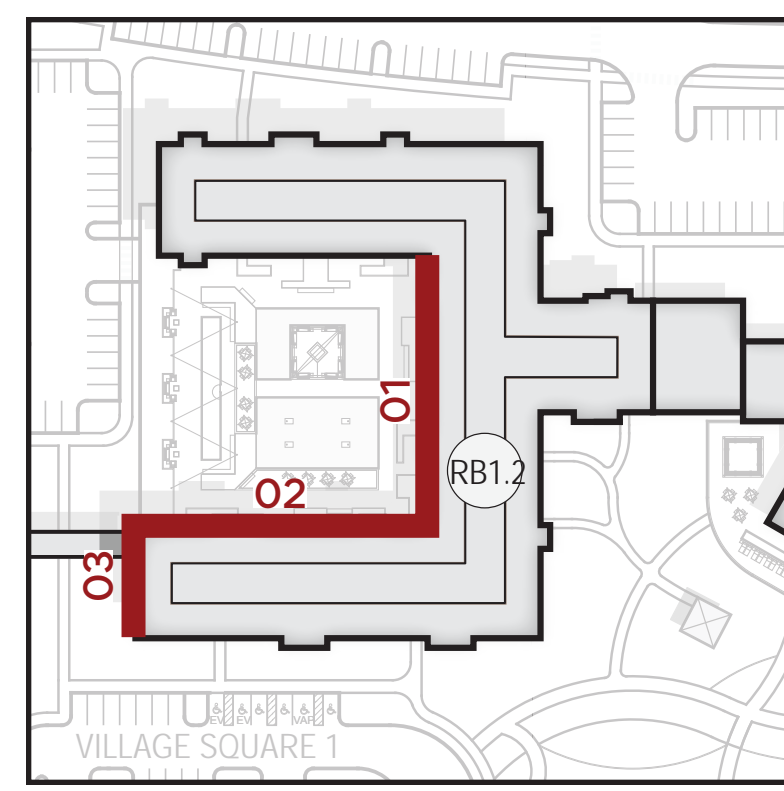

01 / RB1.2 - WEST ELEVATION 02
SCALE: 1/8" = 1'



02 / RB1.2 - NORTH ELEVATION 03
SCALE: 1/8" = 1'

03 / RB1.2 - WEST ELEVATION 03
SCALE: 1/8" = 1'

EXTERIOR ELEVATIONS - RB1.2

ERICKSON SENIOR LIVING - WEST ROSEVILLE

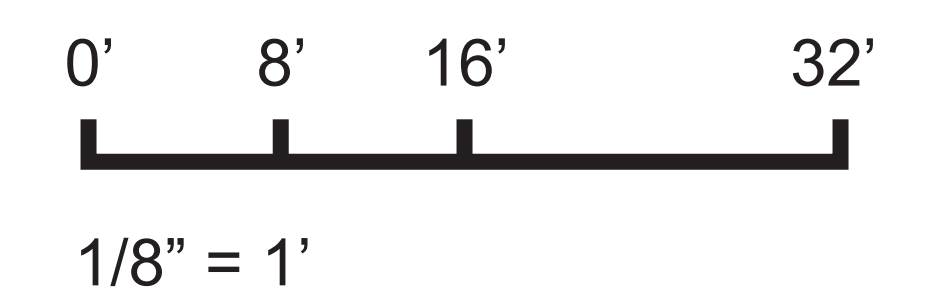

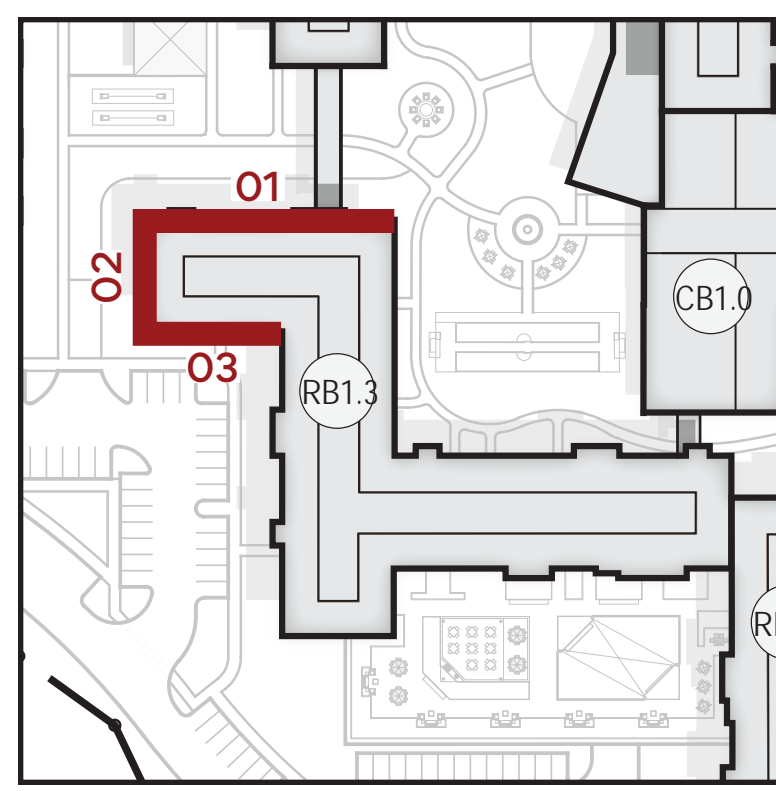

01 / RB1.3 - NORTH ELEVATION 01
SCALE: 1/8" = 1'



02 / RB1.2 - WEST ELEVATION 02
SCALE: 1/8" = 1'

03 / RB1.2 - SOUTH ELEVATION 03
SCALE: 1/8" = 1'

EXTERIOR ELEVATIONS - RB1.3

ERICKSON SENIOR LIVING - WEST ROSEVILLE

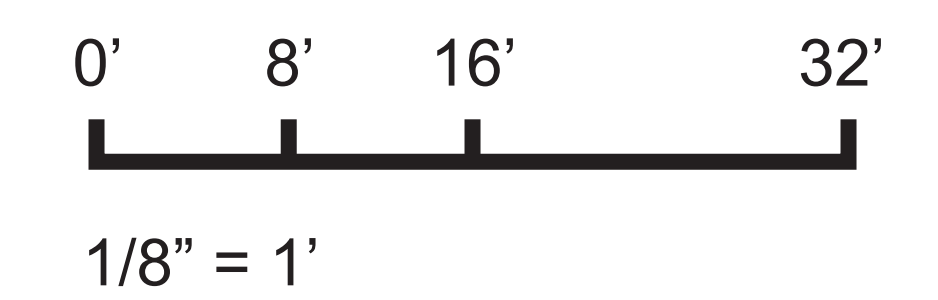

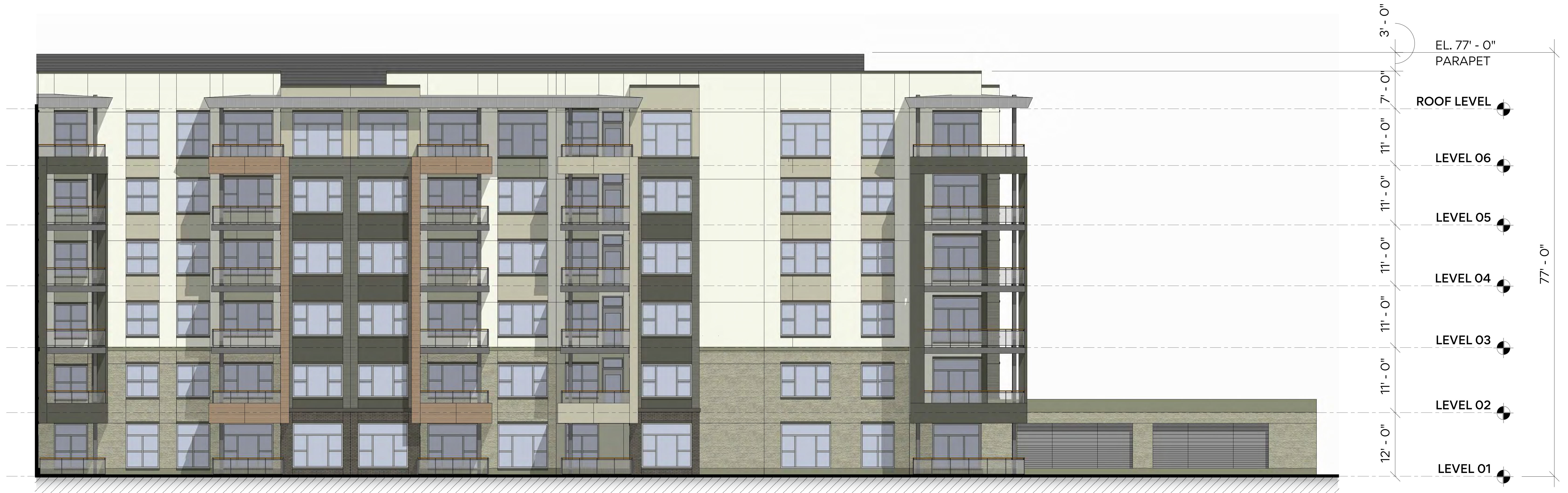
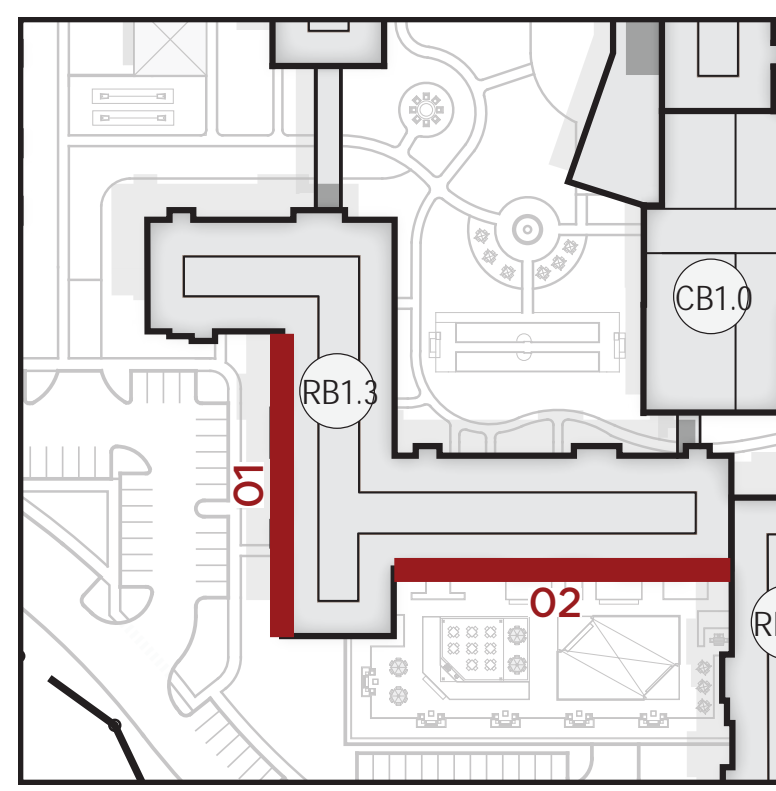

01 / RB1.3 - WEST ELEVATION 01
SCALE: 1/8" = 1'



02 / RB1.2 - SOUTH ELEVATION 02
SCALE: 1/8" = 1'

EXTERIOR ELEVATIONS - RB1.3

ERICKSON SENIOR LIVING - WEST ROSEVILLE

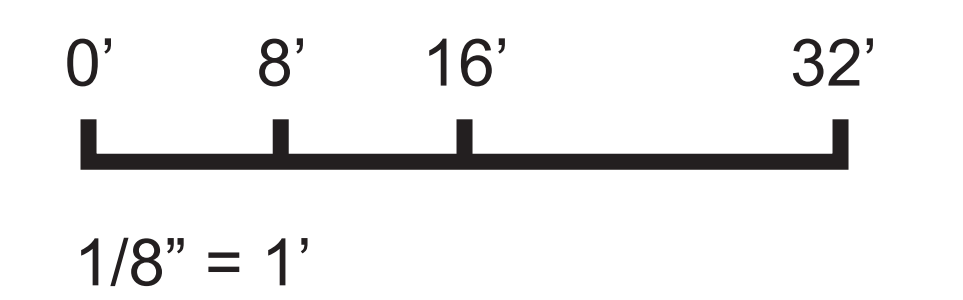

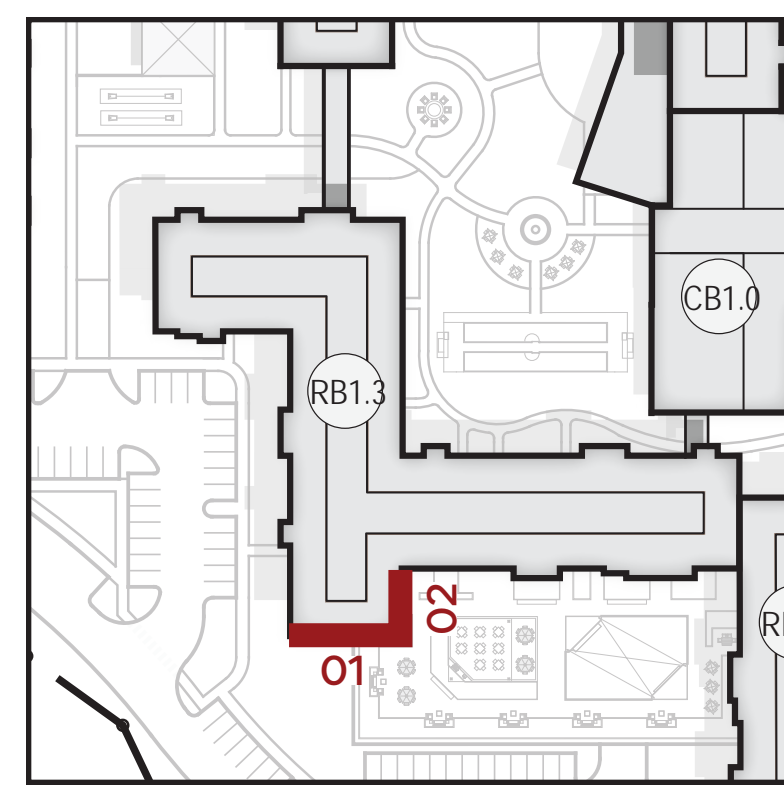

01 / RB1.3 - SOUTH ELEVATION 01
SCALE: 1/8" = 1'



02 / RB1.3 - EAST ELEVATION 01
SCALE: 1/8" = 1'

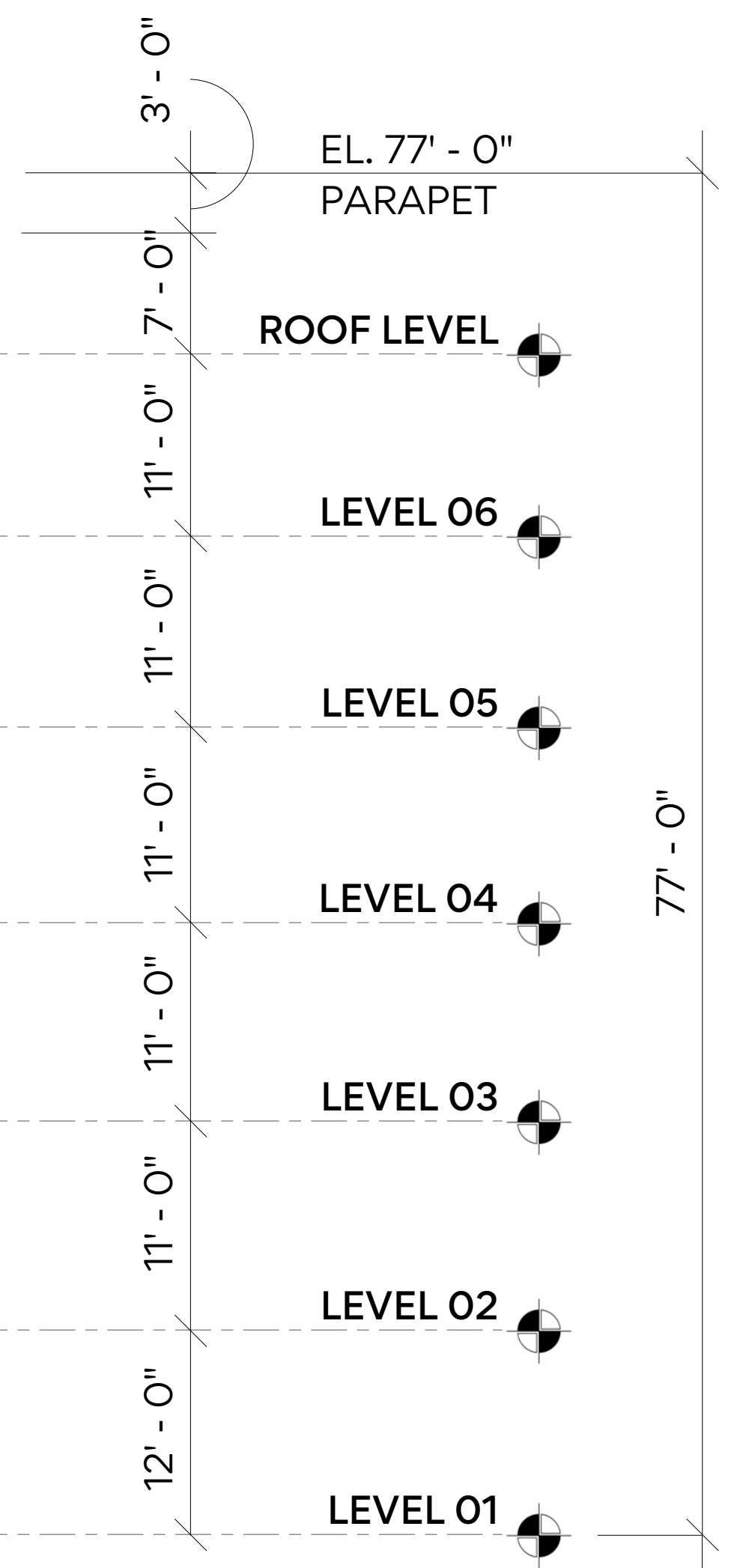



MARKETING CENTER NORTH ELEVATION

SCALE: 1/8" = 1'-0"

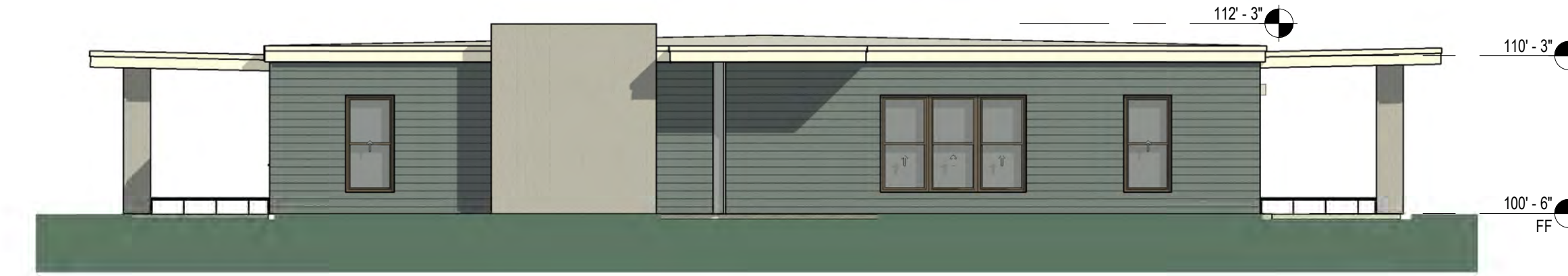

MARKETING CENTER EAST ELEVATION

SCALE: 1/8" = 1'-0"



MARKETING CENTER SOUTH ELEVATION

SCALE: 1/8" = 1'-0"

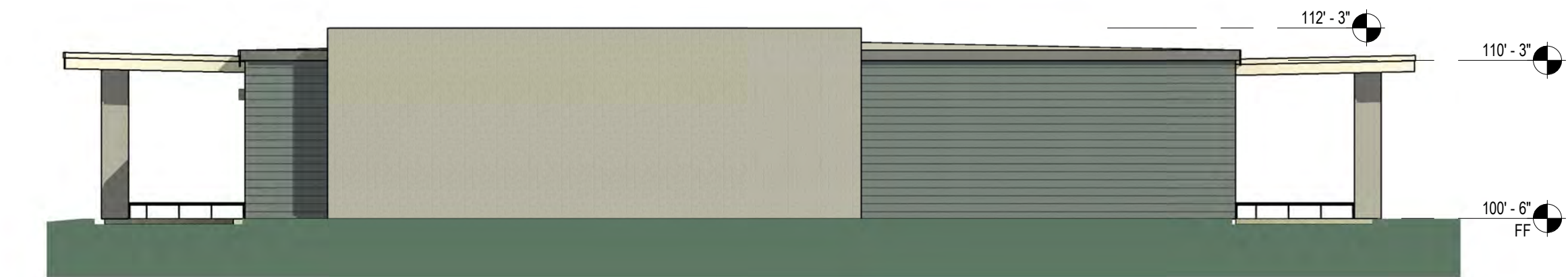

MARGETING CENTER WEST ELEVATION

SCALE: 1/8" = 1'-0"

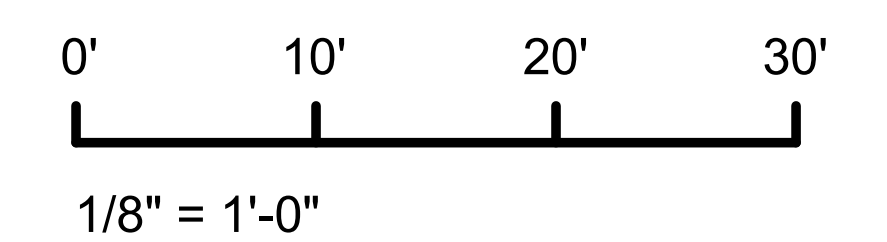
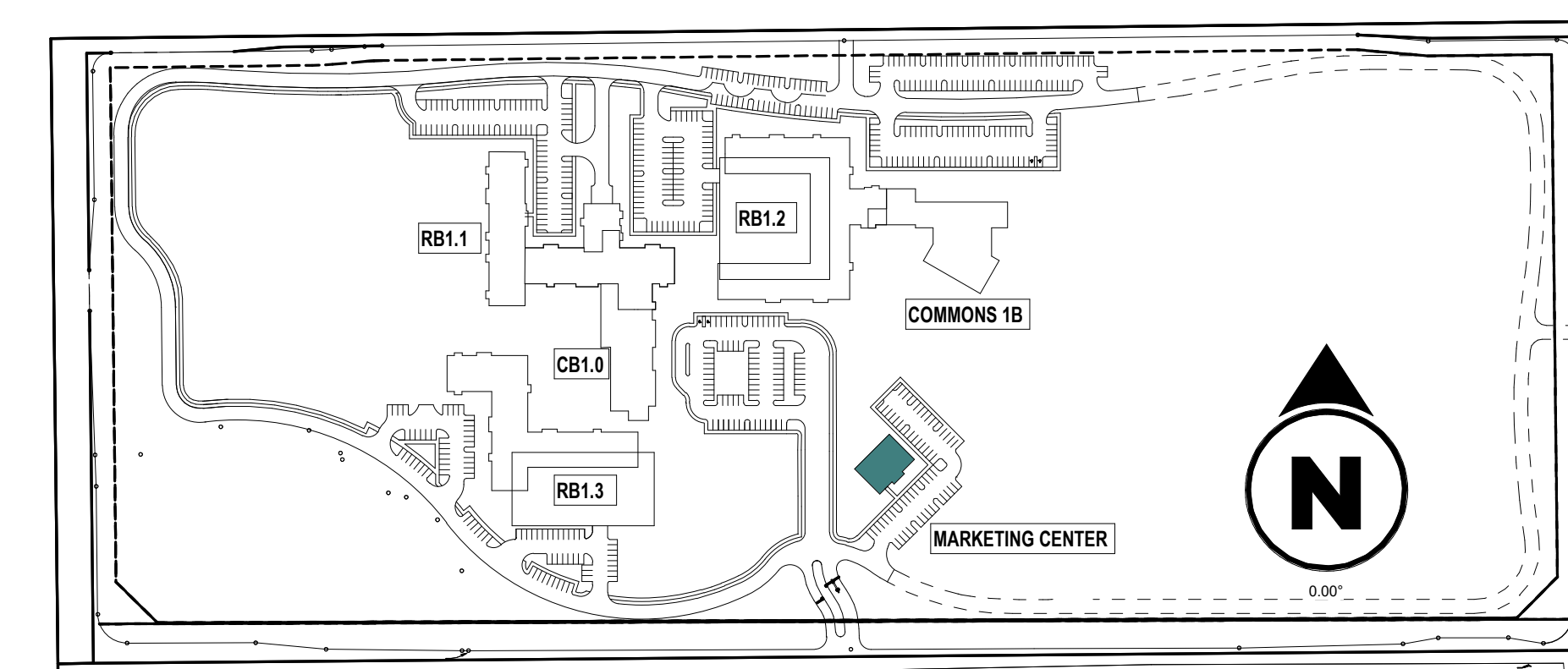

Erickson Senior Living Roseville
MPP Stage 2 North Elevation - Marketing Center
Sierra Vista, West Roseville, CA



FS-01
PLANK LAP SIDING

TYPE: Fiber-cement planks

FINISH: Smooth texture
Manufacturer Primed for Paint
SW 6201 Thunderous or sim.

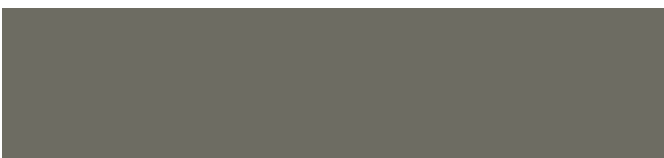

Window trim + accent trim:
SW 7020 Black Fox or sim.

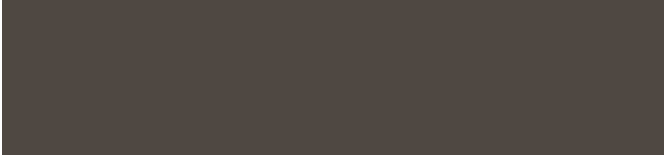

FS-02
VERTICAL SIDING

TYPE: Fiber-cement panel siding in vertical format
Window trim + accent trim to match

FINISH: Cedar texture
Painted
SW 2848 Roycroft Pewter or sim.



MA-01
STONE

TYPE: Manufactured Stone Veneer
Corner units Required
Sill/Cap Stone where Required

FINISH: Hewn
Color as shown above or sim.

MA-02
BRICK

TYPE: Face Brick
Modular, Norman, or Utility
Cast Stone Sill/Cap where Required

FINISH: Velour
Color as shown above or sim.

MA-03
BRICK

TYPE: Face Brick
Modular, Norman, or Utility
Cast Stone Sill/Cap where Required

FINISH: Smooth
Color as shown above or sim.

Designations Below
PAINTED STUCCO

TYPE: Two-coat assembly over metal lathe

FINISH: Smooth
SW 7004 Snowbound or sim.
ST-01

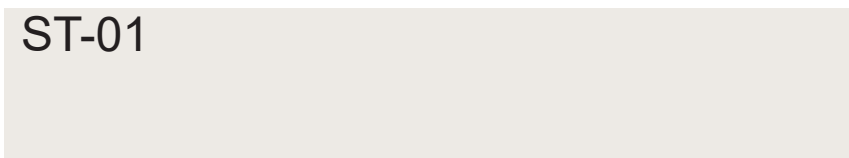

FINISH: Smooth
SW 7017 Dorian Gray or sim.
ST-02

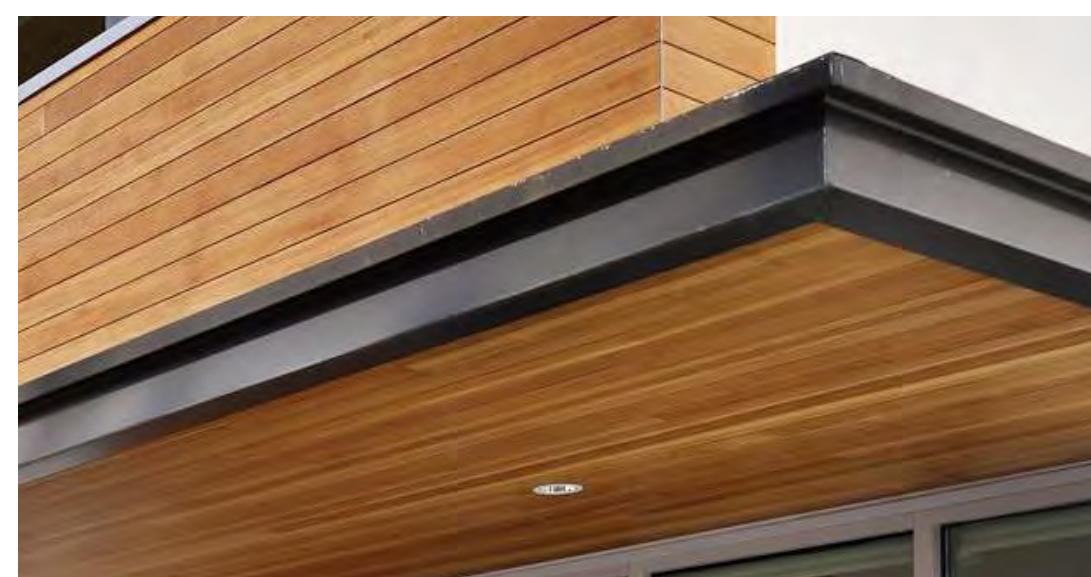
Designations Below
CANOPY MTL TRIM

TYPE: Fascia Panel System

FINISH: SILVER METALLIC OR SIM.
MT-01



Color Match SW 2848 Roycroft
Pewter
MT-02

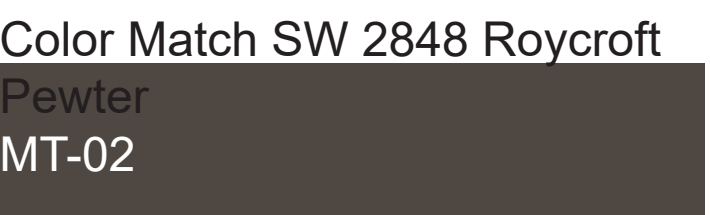

MT-03
STANDING SEAM METAL ROOF

TYPE: Concealed Fastening System

Matching color
for all trim and accessories

FINISH: Pewter or sim.



WD-01
CANOPY WOOD-LIKE SOFFIT

TYPE: Aluminum Fiber Cement board or Sim.
Composite Panel System

FINISH: Western Red Cedar or Sim.



MR-01
PAINTED STEEL RAILING

TYPE: High-temp baked enamel

FINISH: SW 2848 Roycroft Pewter or sim.

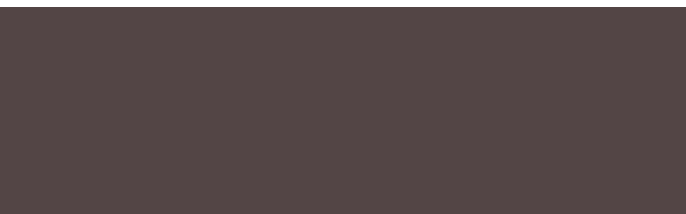

MR-02
WELDED WIRE STEEL RAILING

TYPE: High-temp baked enamel

FINISH: SW 2848 Roycroft Pewter or sim.



W-01
FRAMED WINDOWS

TYPE: Vinyl Framed Windows

FINISH: Medium gray exterior color



W-02
STOREFRONT WINDOWS

TYPE: Aluminum mullion storefront glazing

FINISH: Clear Anodized



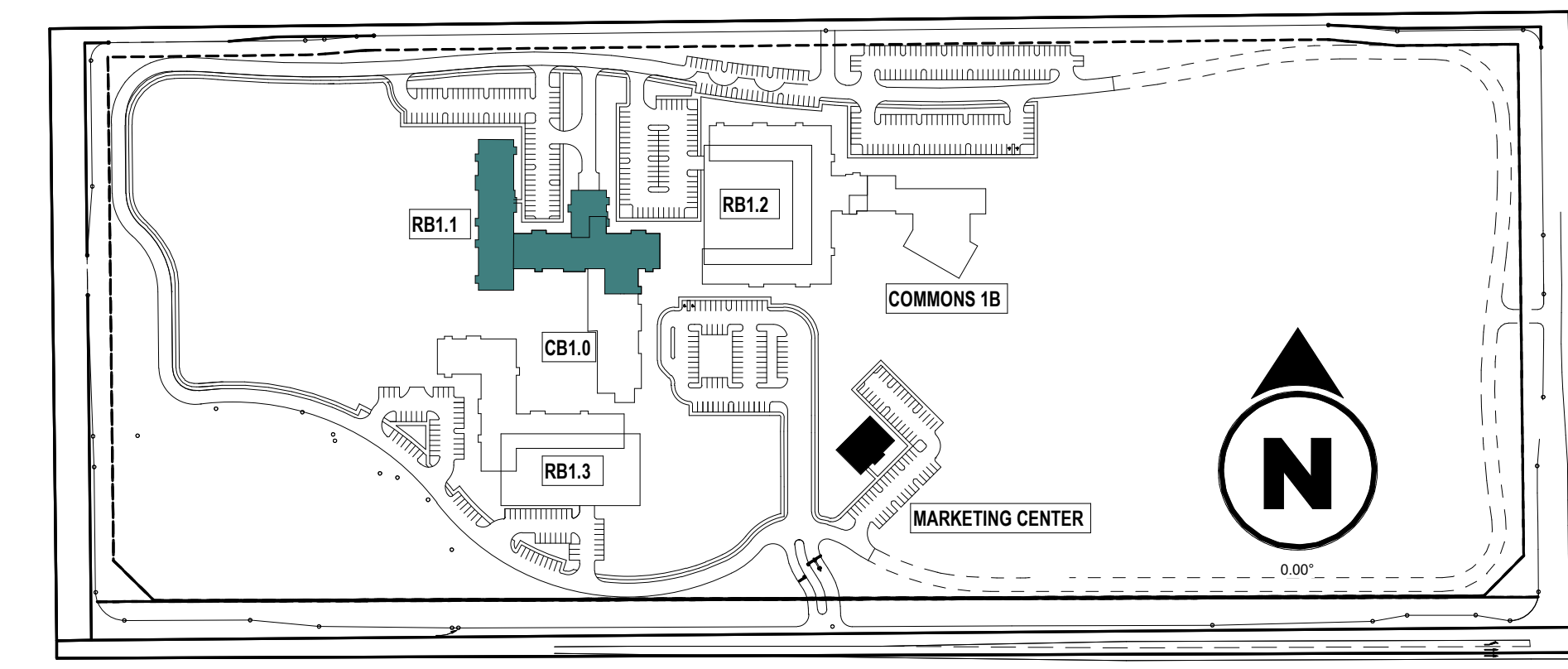
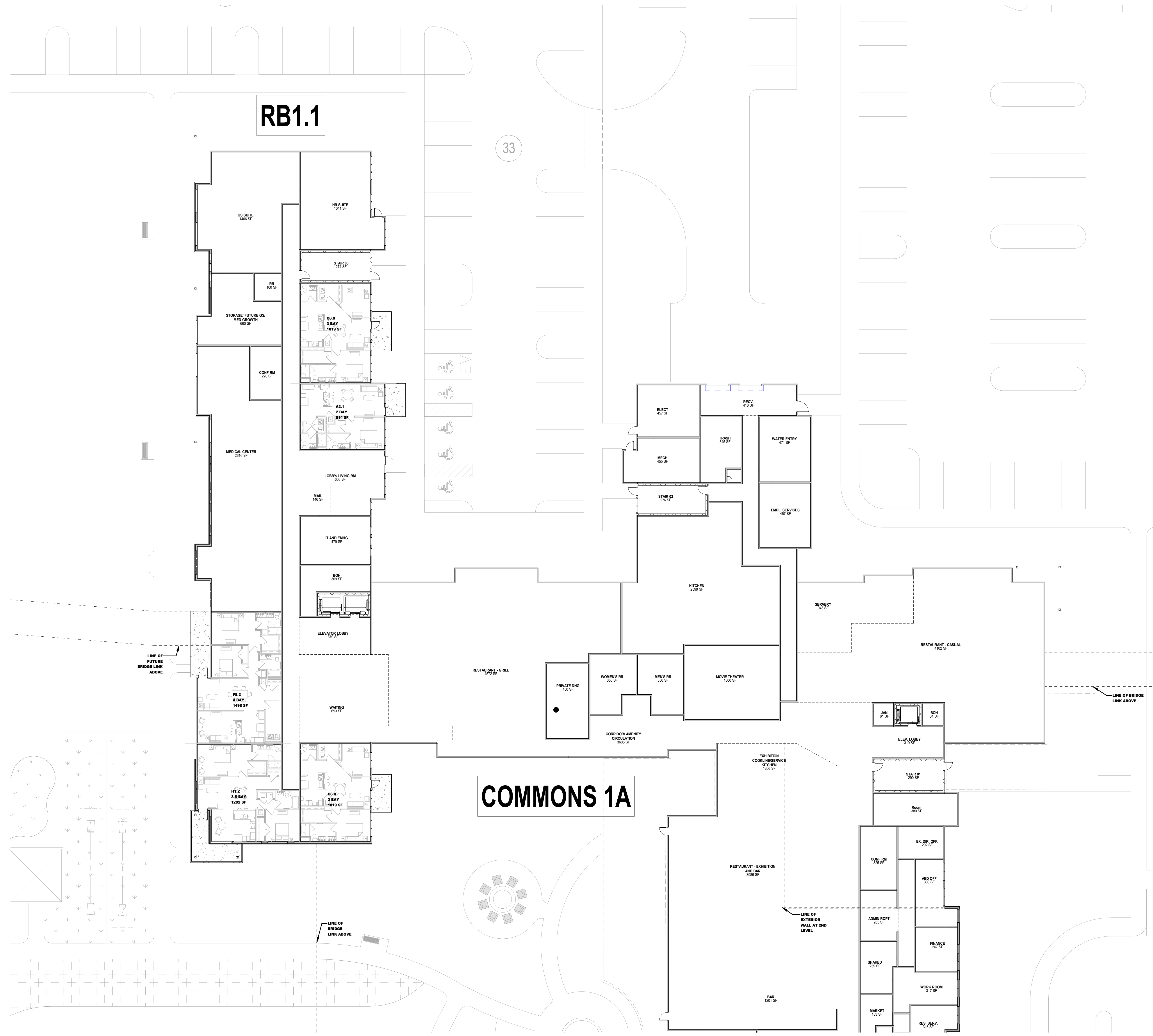

Erickson Senior Living Roseville
 MPP Stage 2 Floor Plan - RB1.1 Ground Level
 Sierra Vista, West Roseville, CA

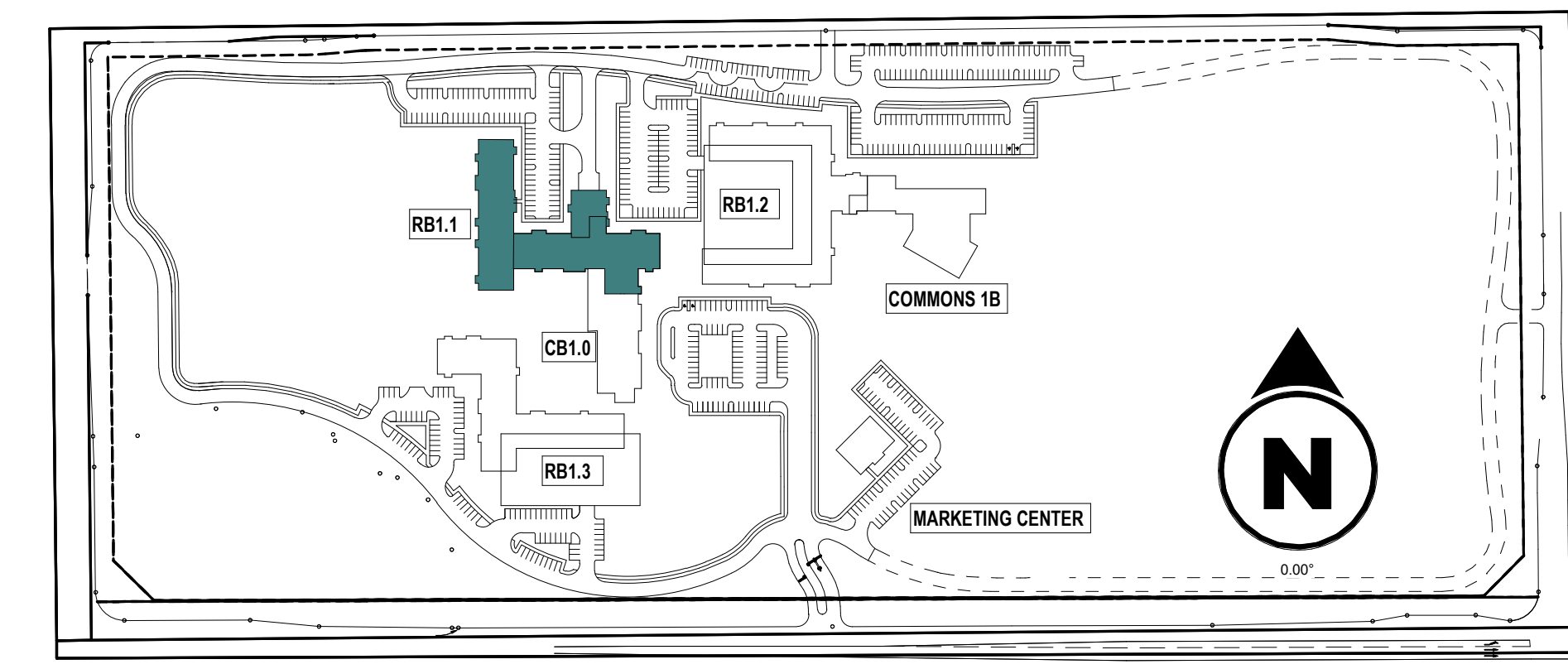

Erickson Senior Living Roseville
 MPP Stage 2 Floor Plan - RB1.1 Third-Fifth Level
 Sierra Vista, West Roseville, CA

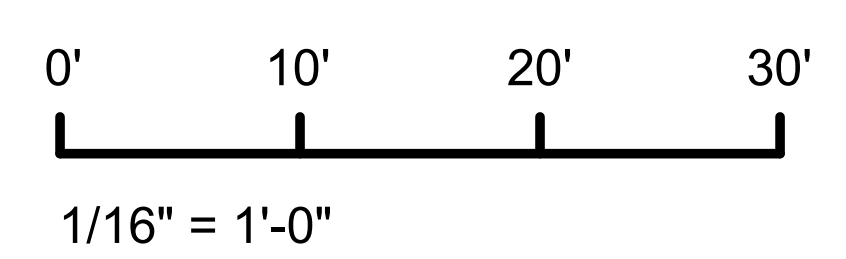

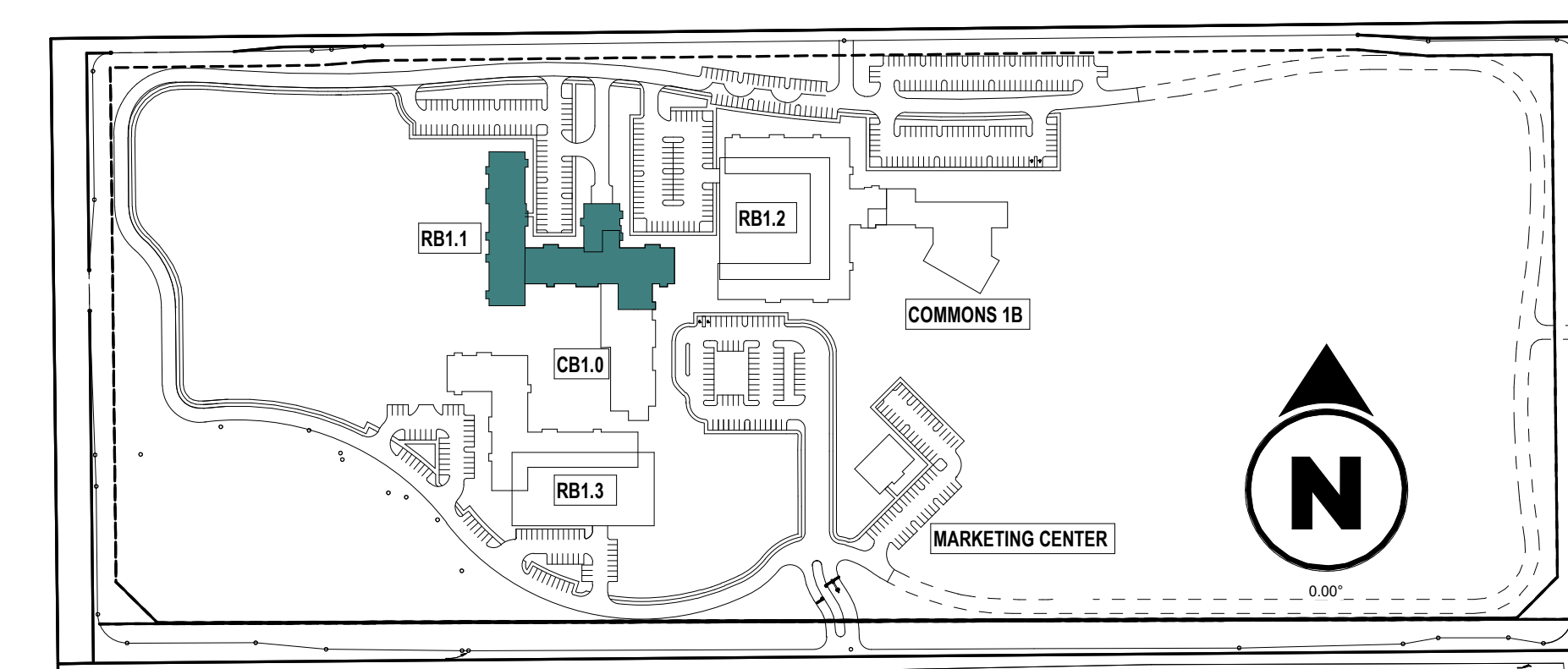
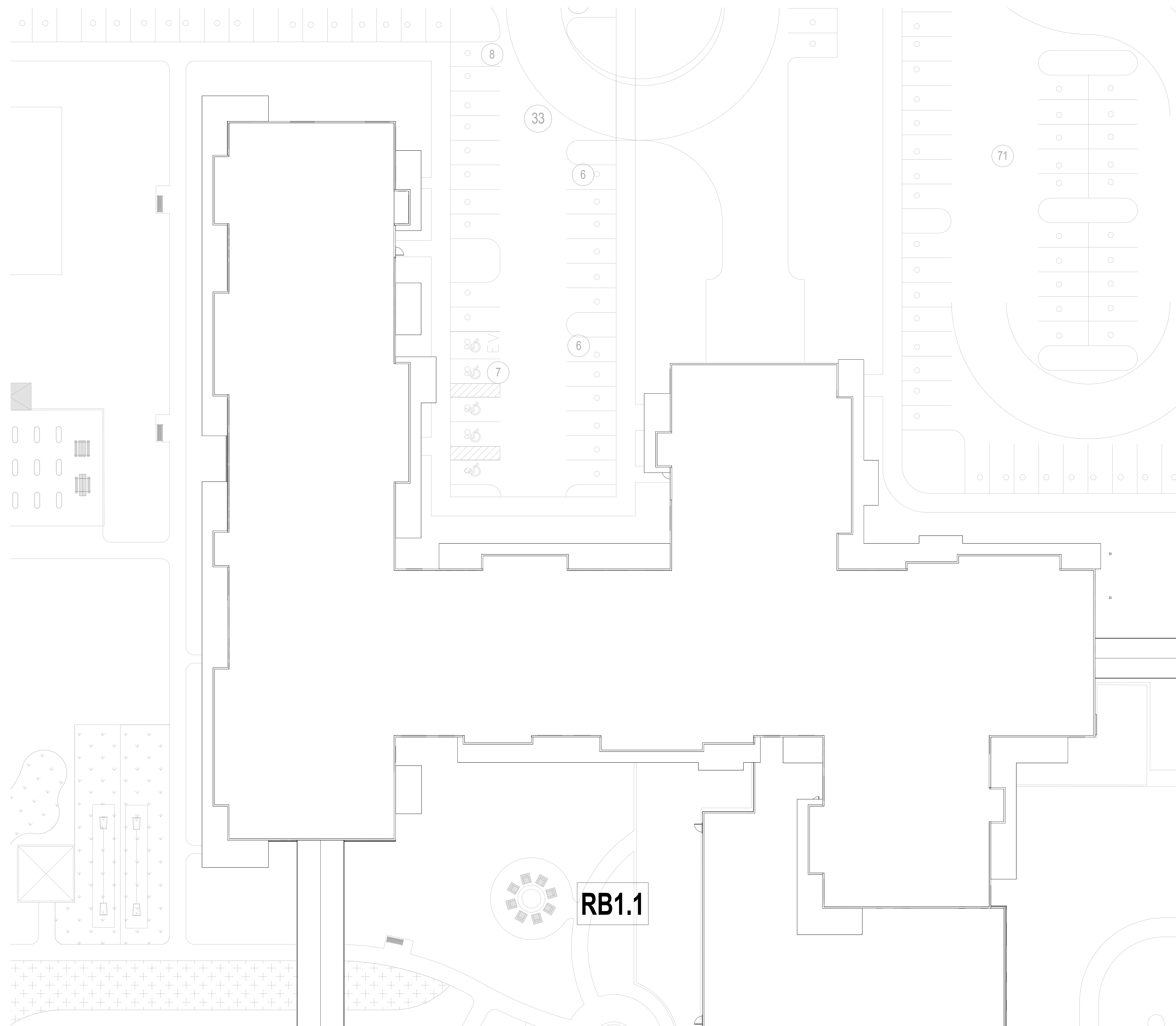

Erickson Senior Living Roseville

MPP Stage 2 Roof Plan - RB1.1

Sierra Vista, West Roseville, CA

0' 10' 20' 30'
1/16" = 1'-0"



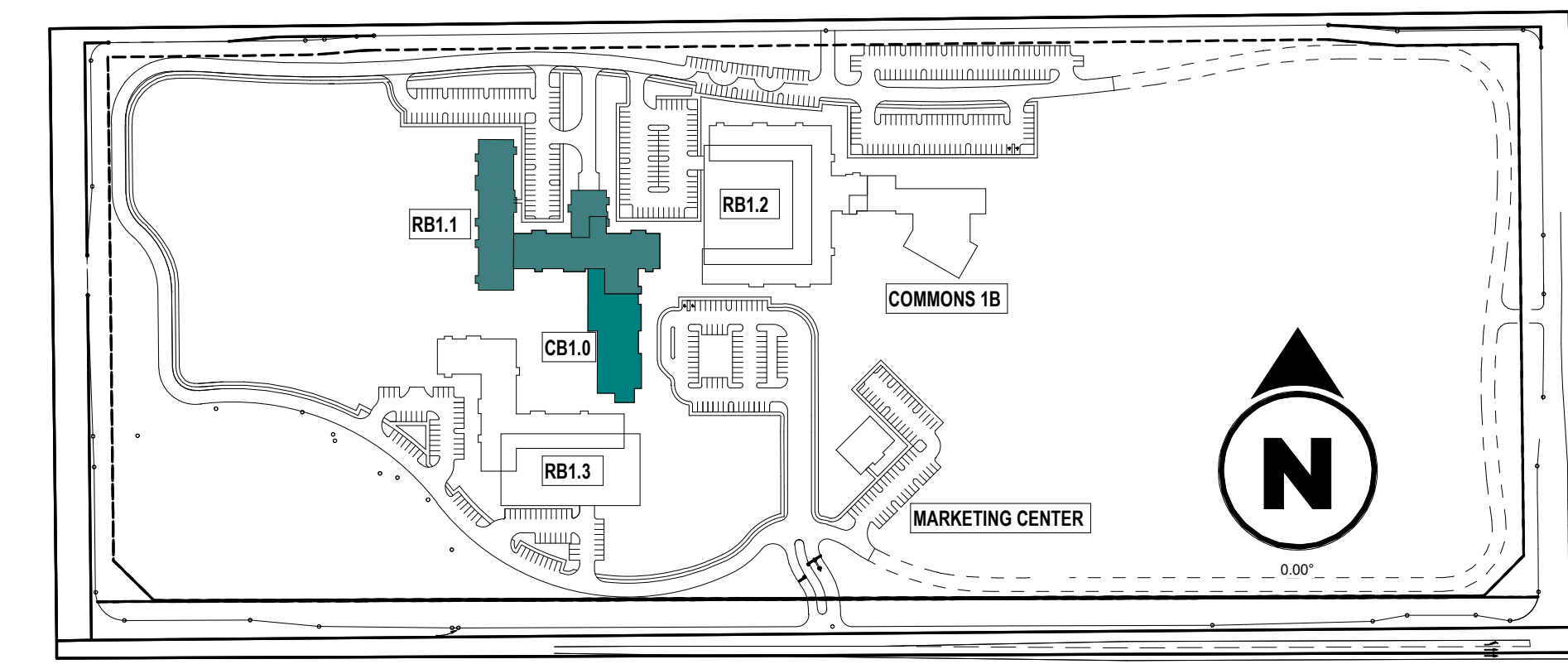
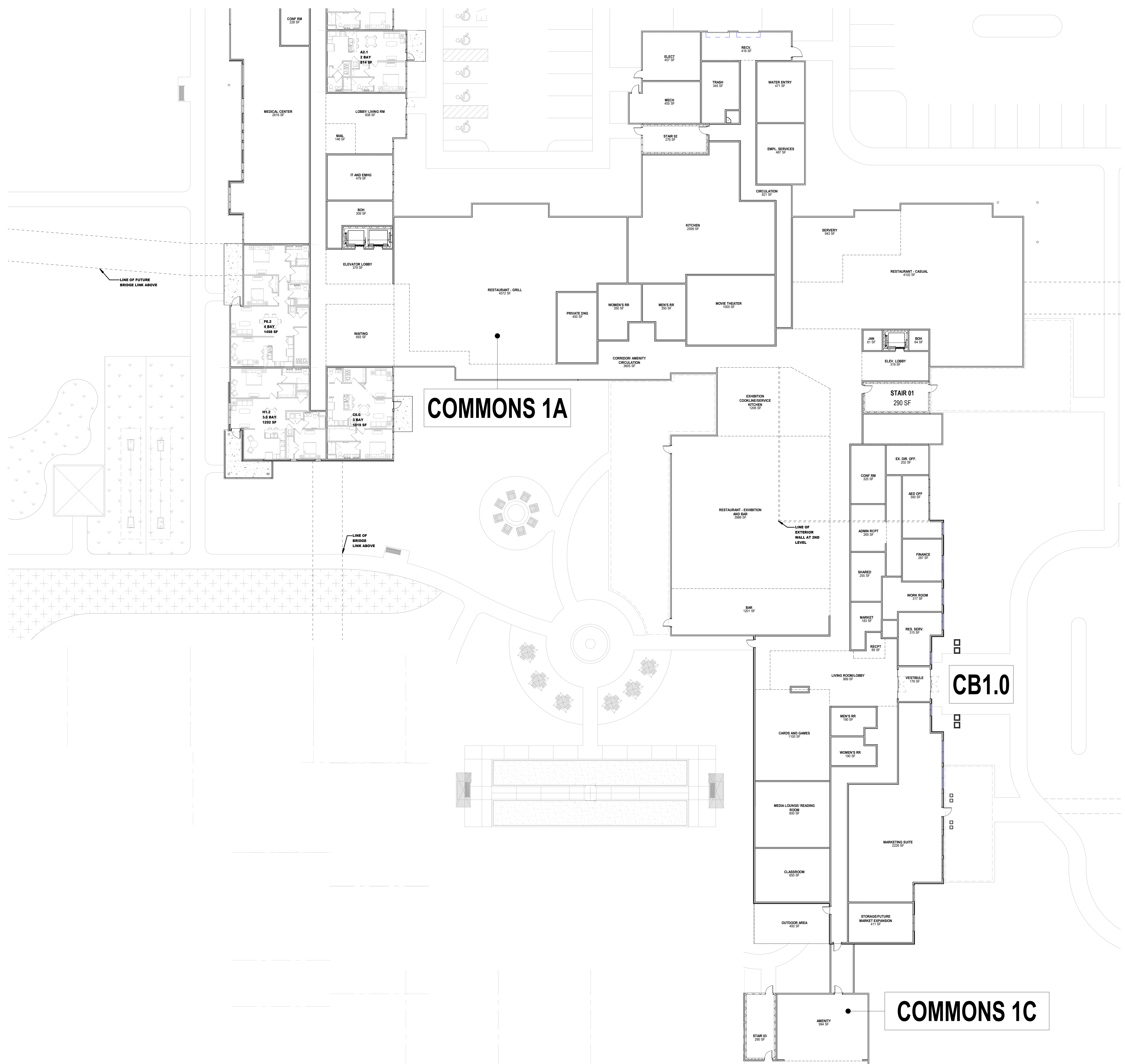

Erickson Senior Living Roseville
 MPP Stage 2 Amenity Floor Plan RB1.1, CB1.0, Commons 1A and 1C
 Sierra Vista, West Roseville, CA

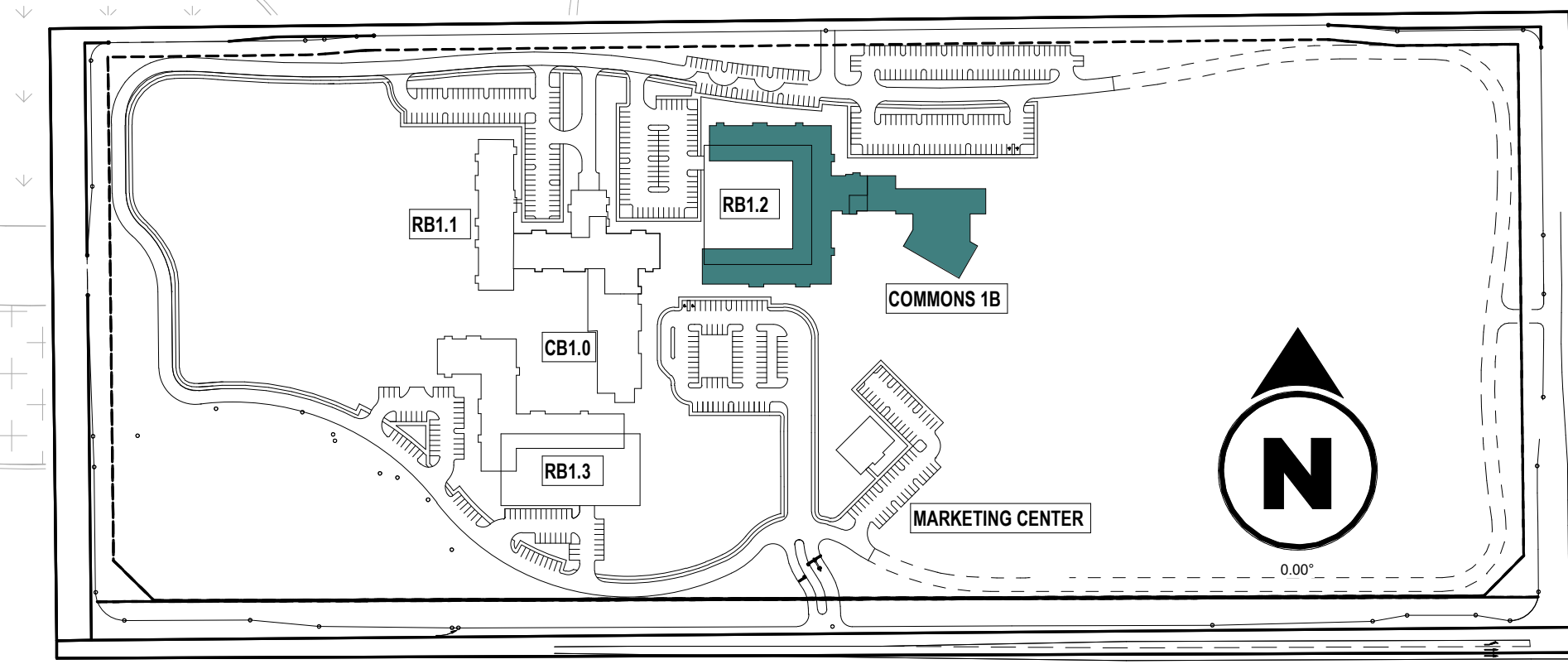
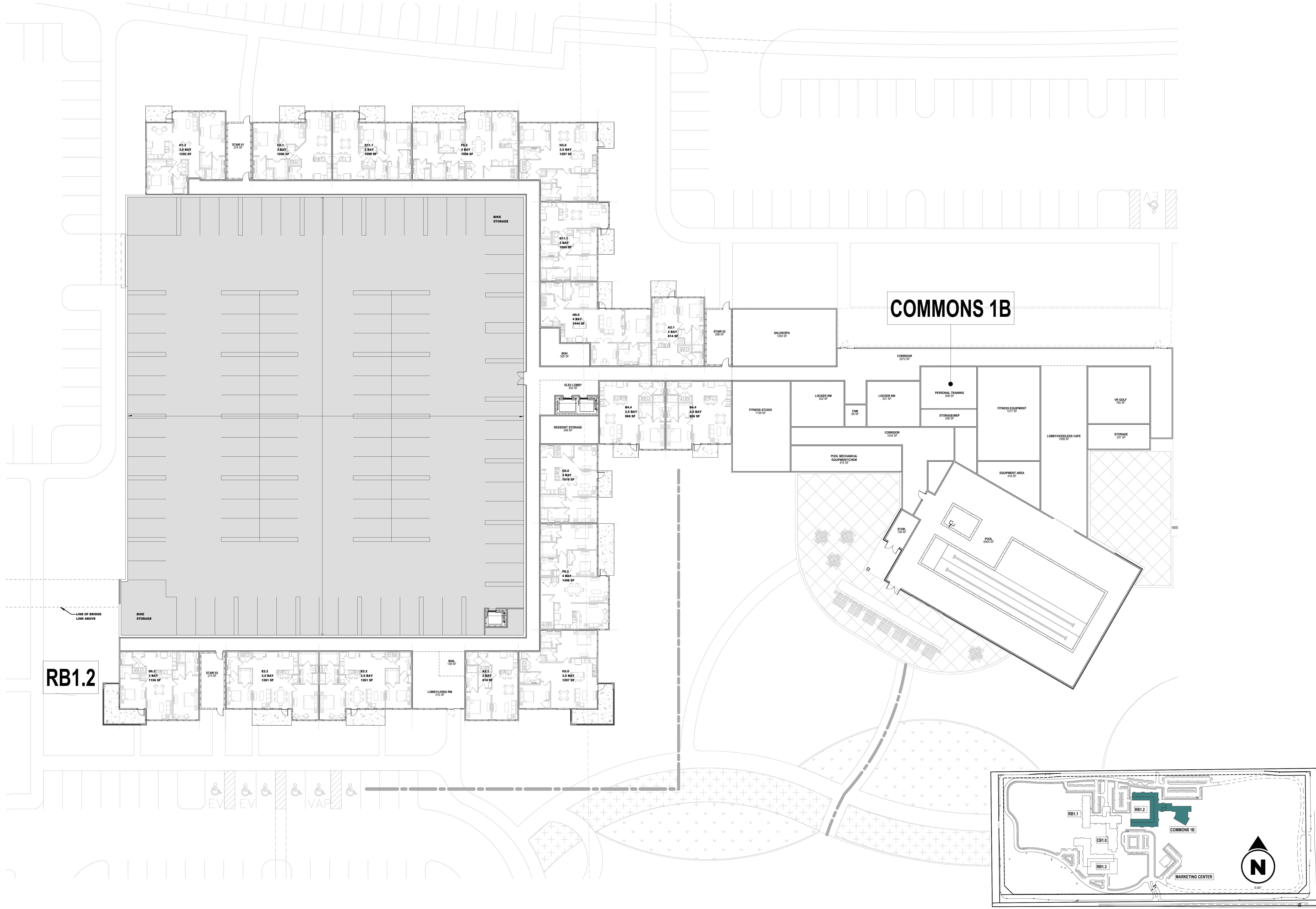

Erickson Senior Living Roseville
 MPP Stage 2 Floor Plan - RB1.2 & Commons 1B Ground Level
 Sierra Vista, West Roseville, CA

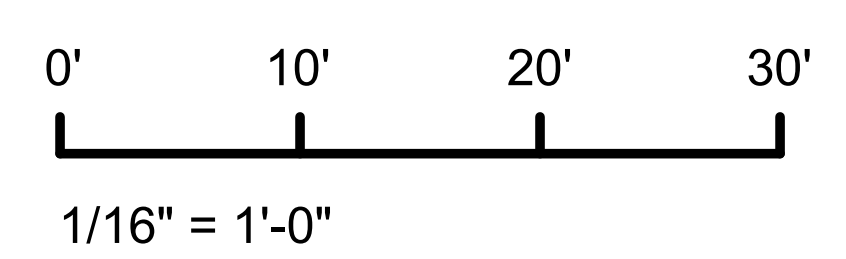

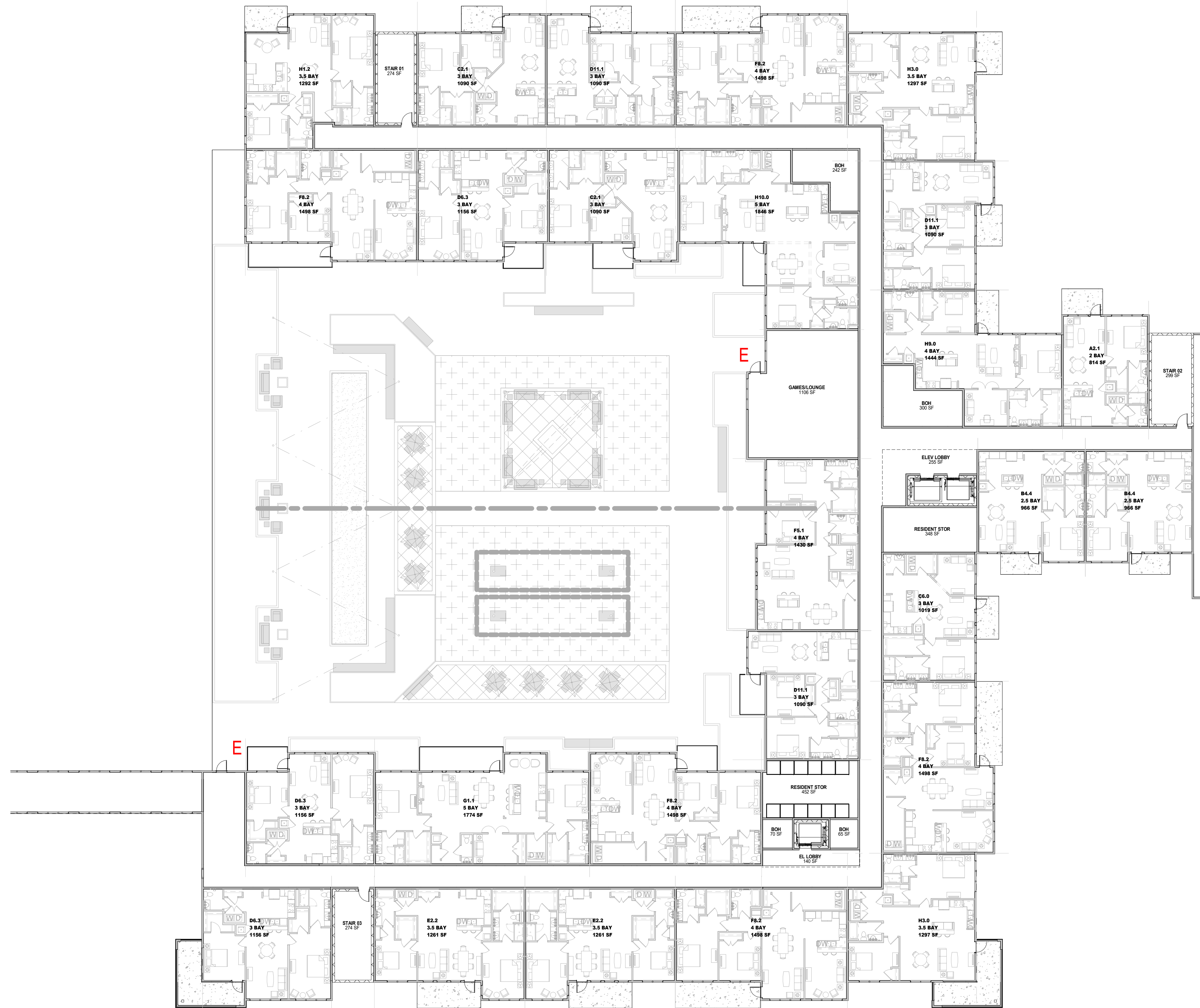

RB1.2

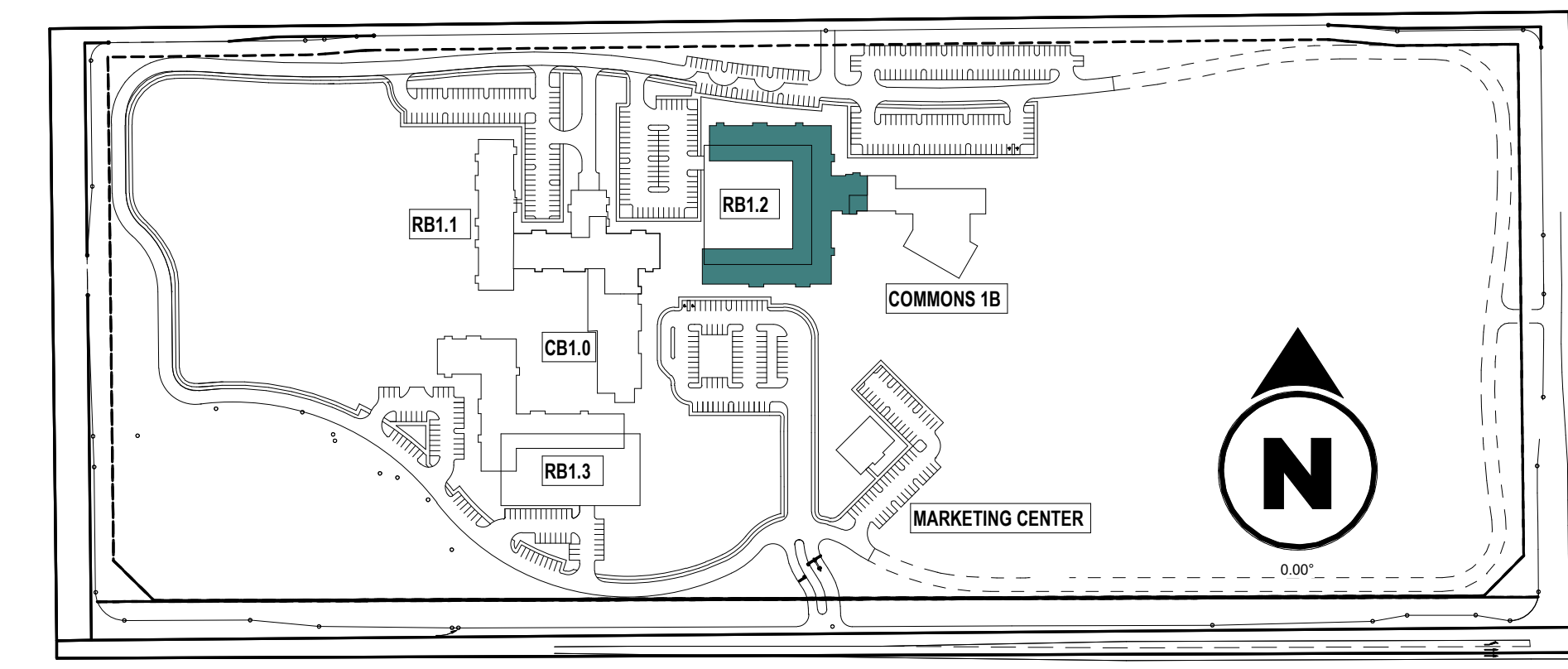

Erickson Senior Living Roseville
 MPP Stage 2 Floor Plan - RB1.2 Second Level
 Sierra Vista, West Roseville, CA

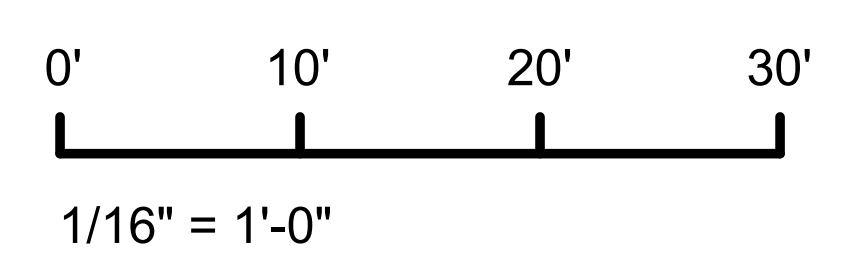

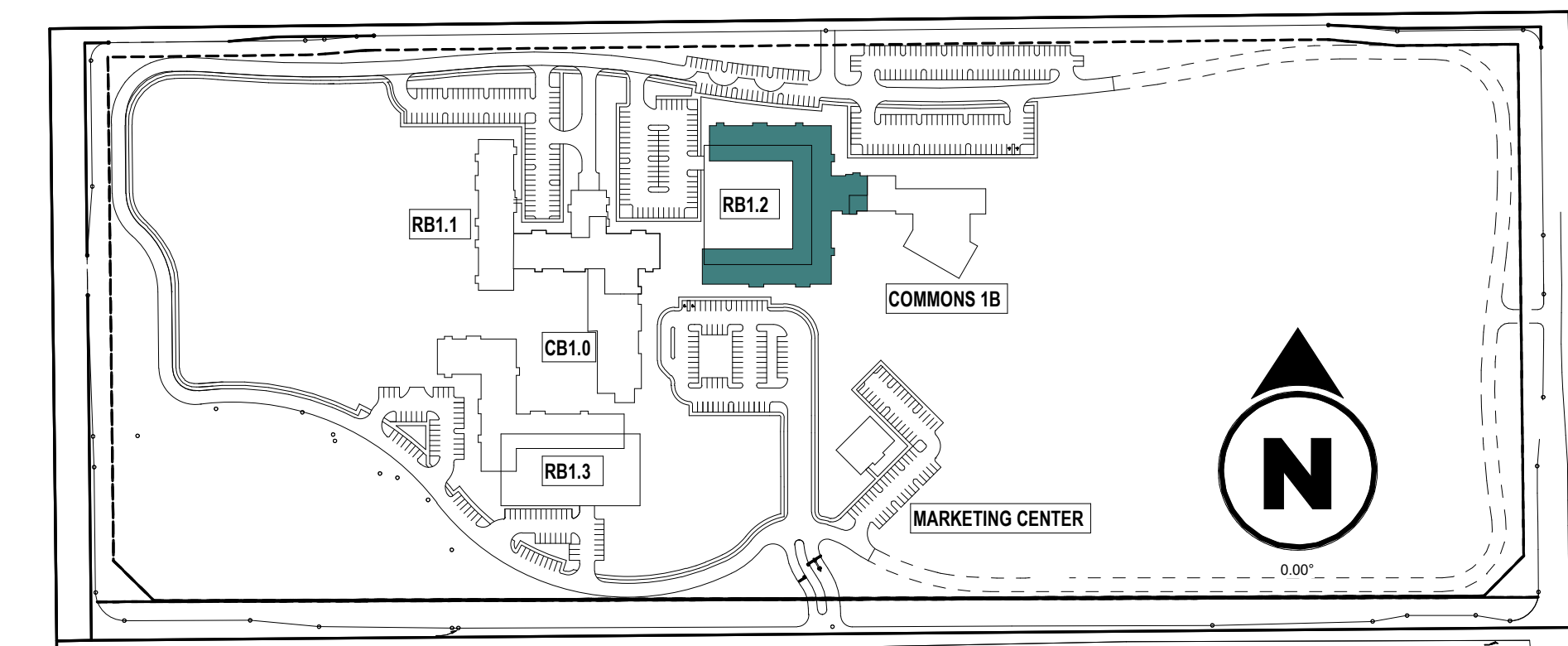
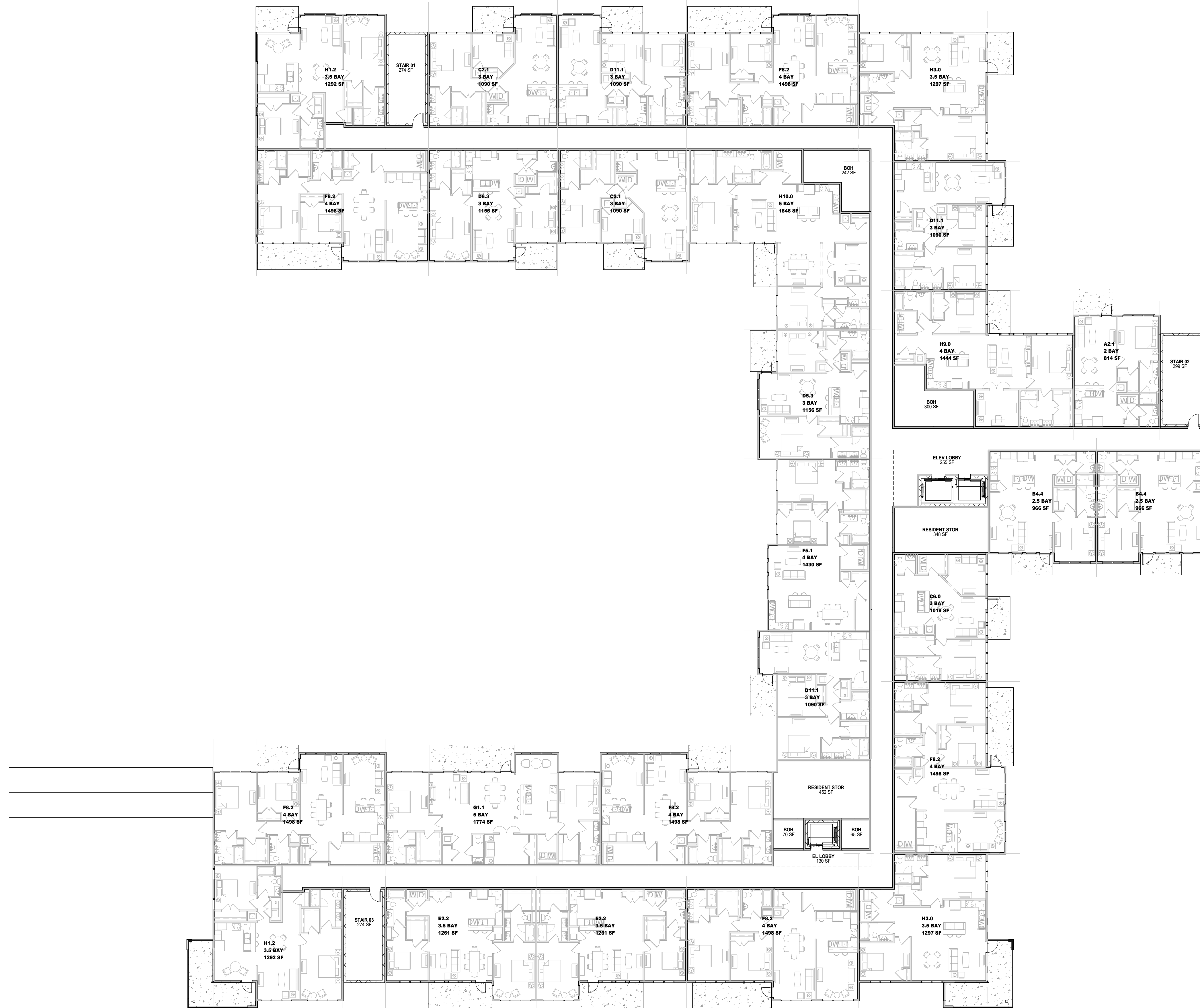

Erickson Senior Living Roseville
 MPP Stage 2 Floor Plan - RB1.2 Third-Fifth Level
 Sierra Vista, West Roseville, CA

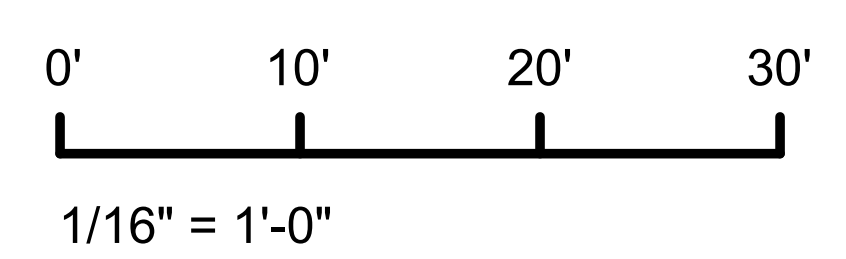

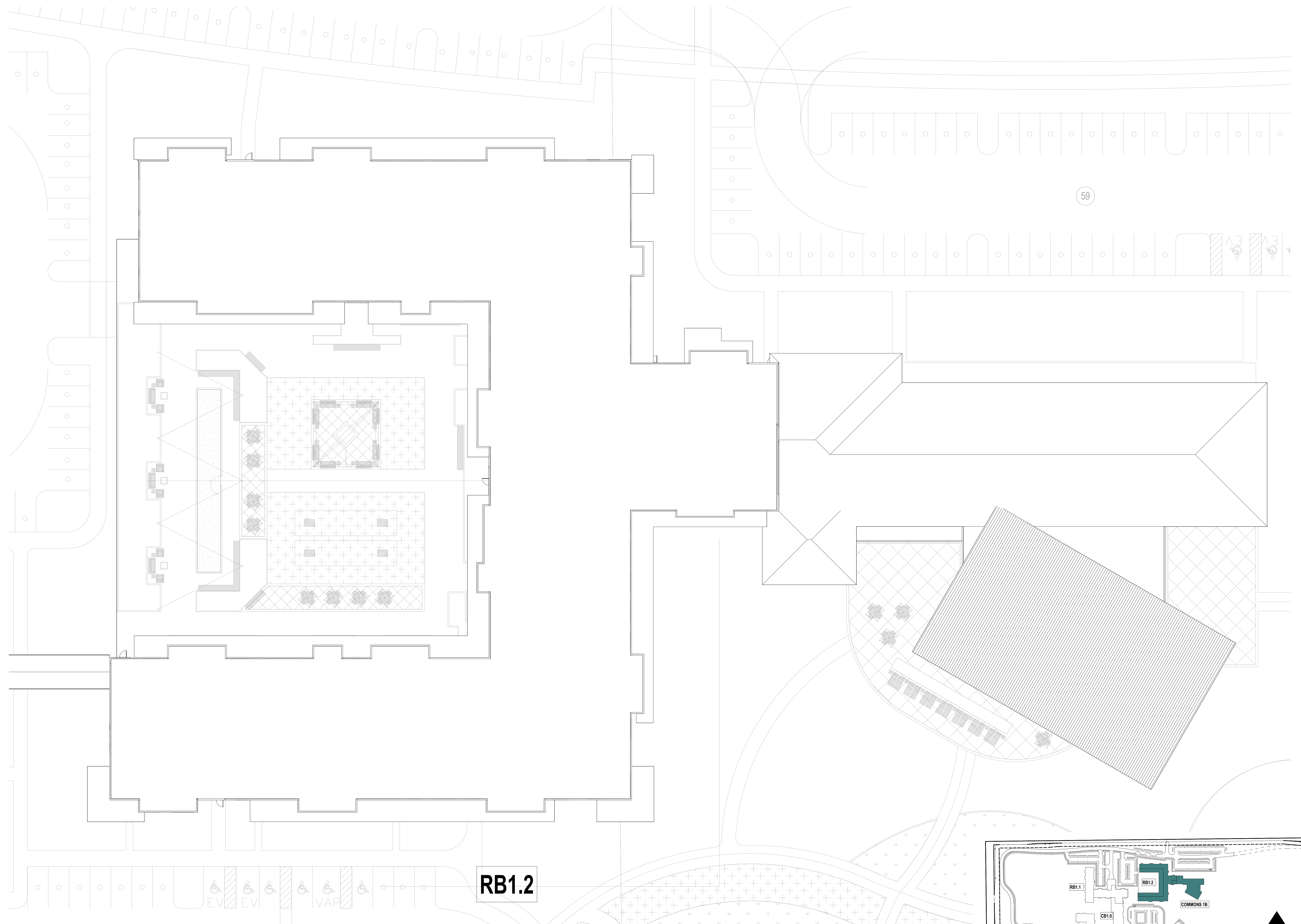

RB1.2

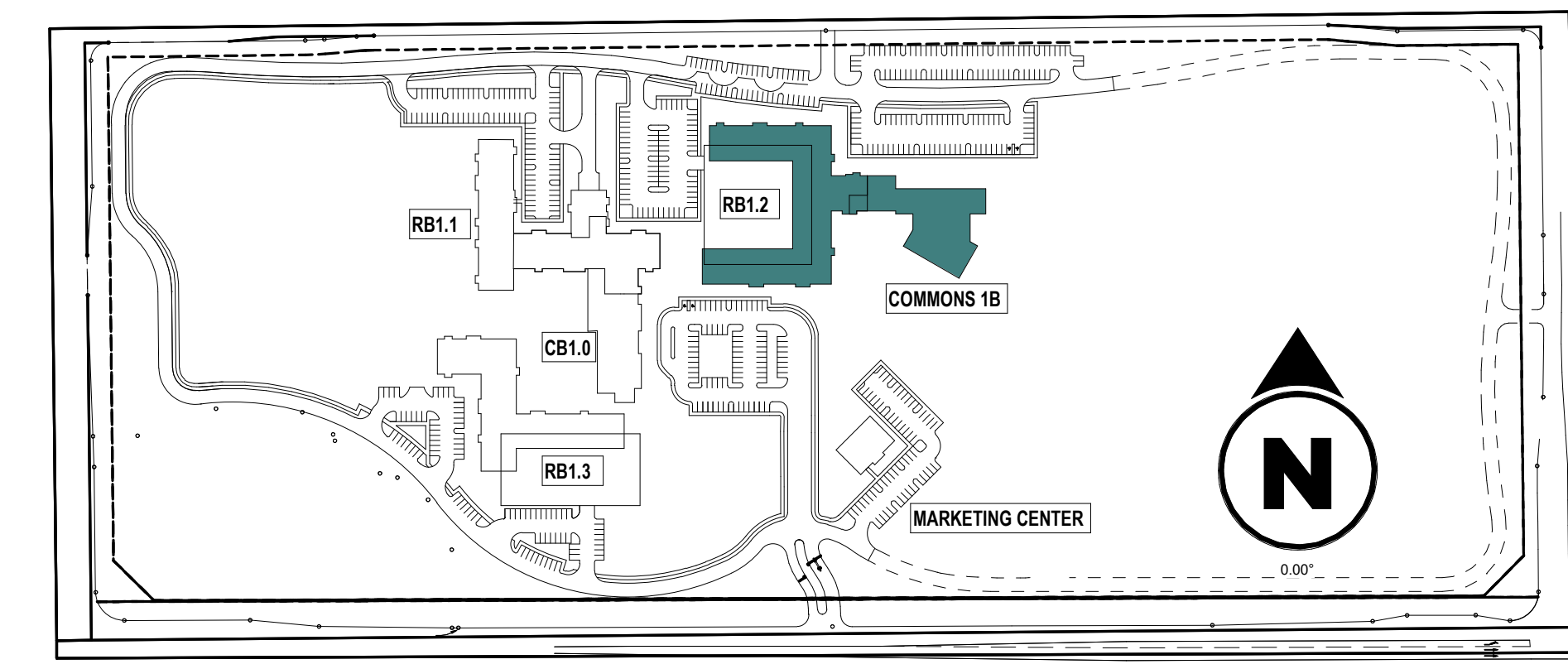

0' 10' 20' 30'
 1/16" = 1'-0"



Erickson Senior Living Roseville
 MPP Stage 2 Roof Plan - RB1.2
 Sierra Vista, West Roseville, CA

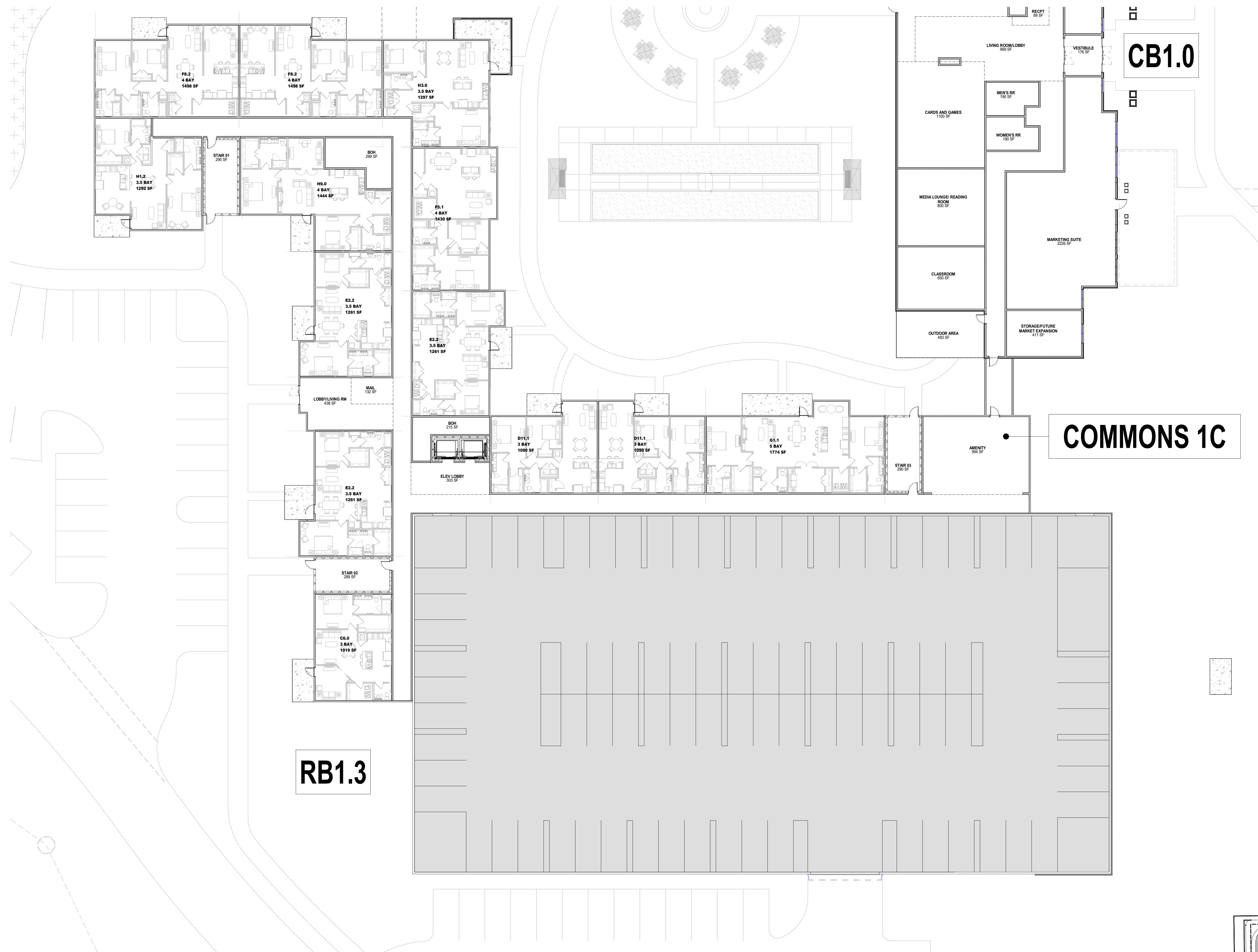

RB1.3

CB1.0

COMMONS 1C

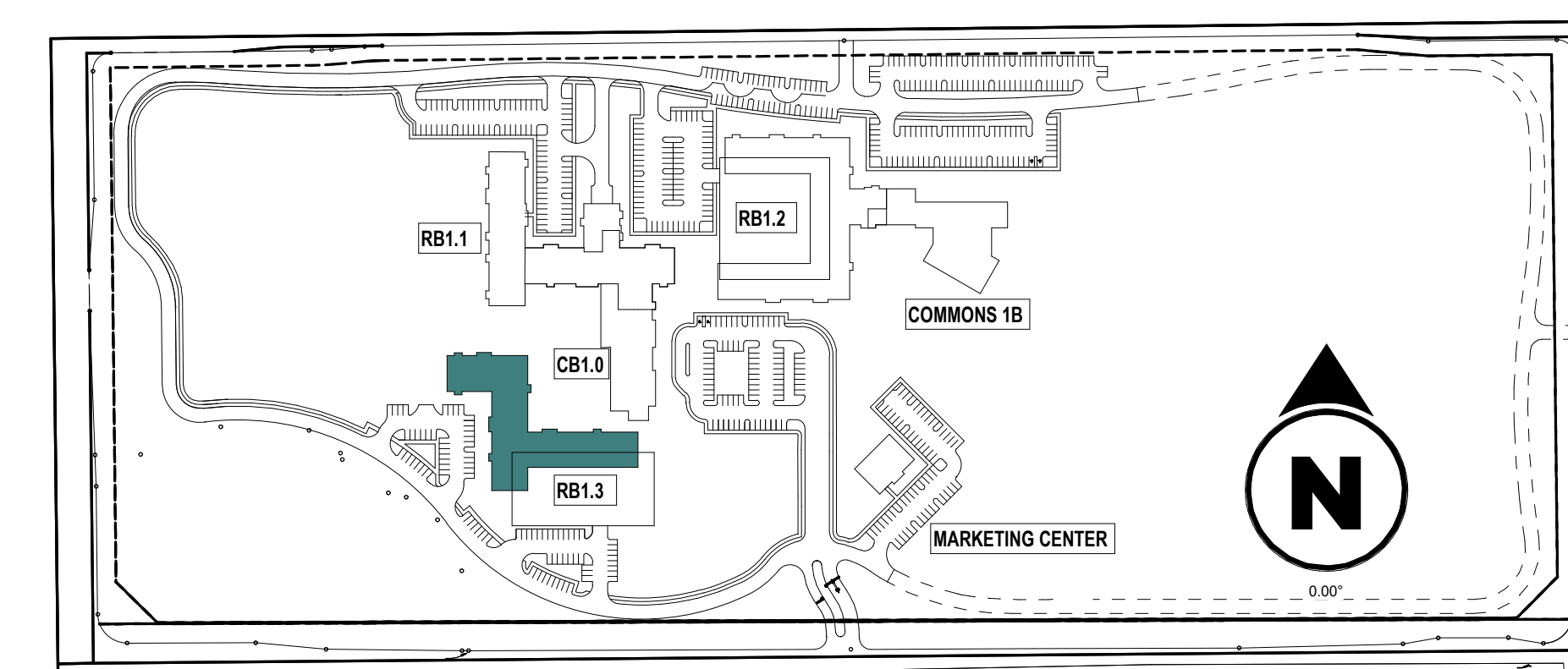

Erickson Senior Living Roseville
 MPP Stage 2 Floor Plan - RB1.3 Ground Level
 Sierra Vista, West Roseville, CA

0' 10' 20' 30'
 1/16" = 1'-0"



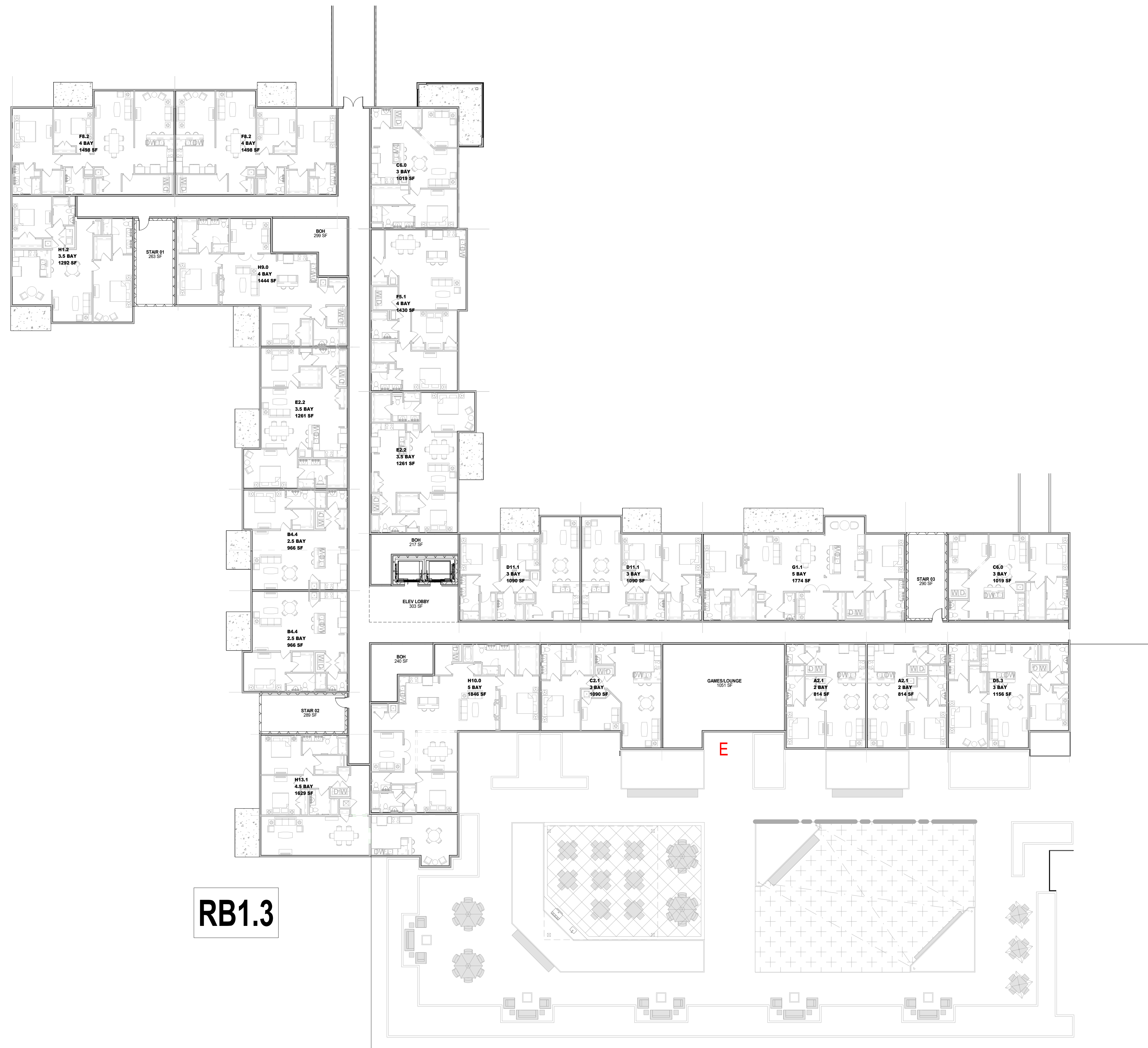

RB1.3

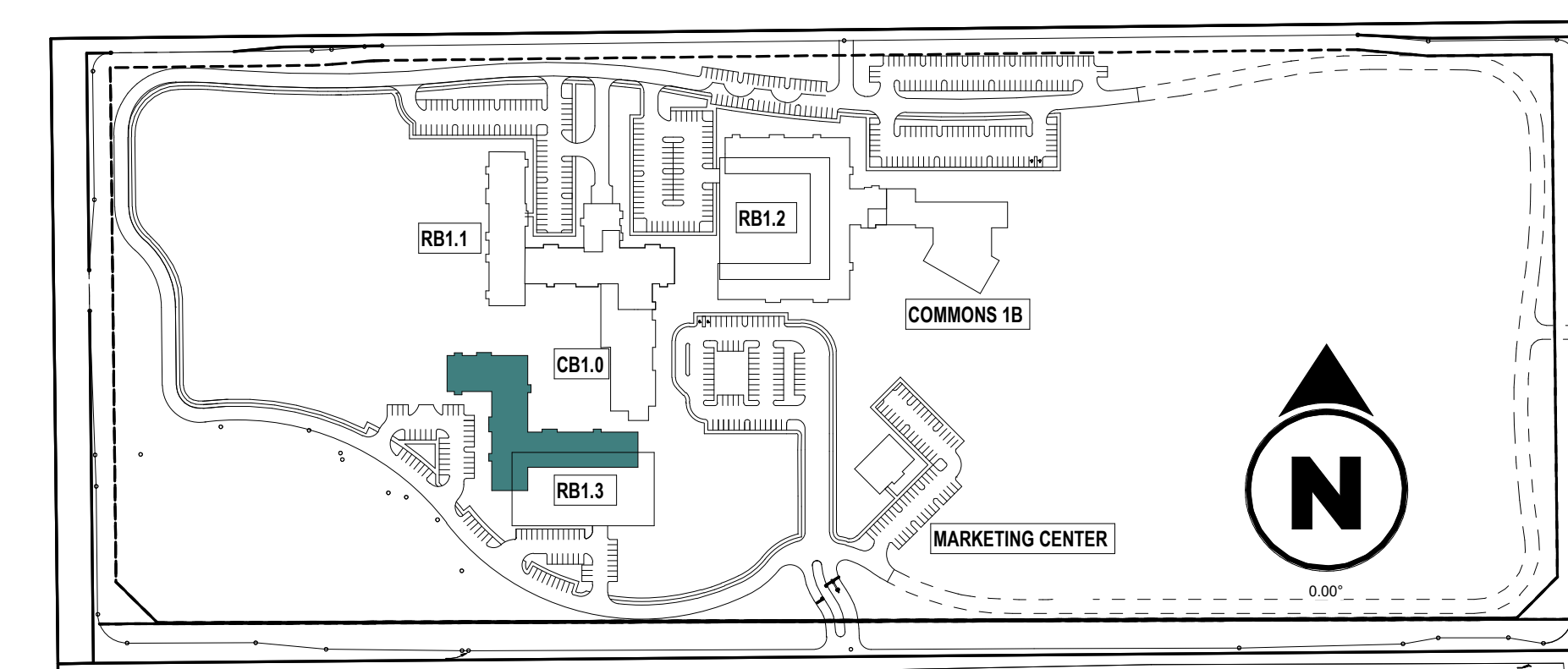

Erickson Senior Living Roseville
 MPP Stage 2 Floor Plan - RB1.3 Second Level
 Sierra Vista, West Roseville, CA

0' 10' 20' 30'
 1/16" = 1'-0"



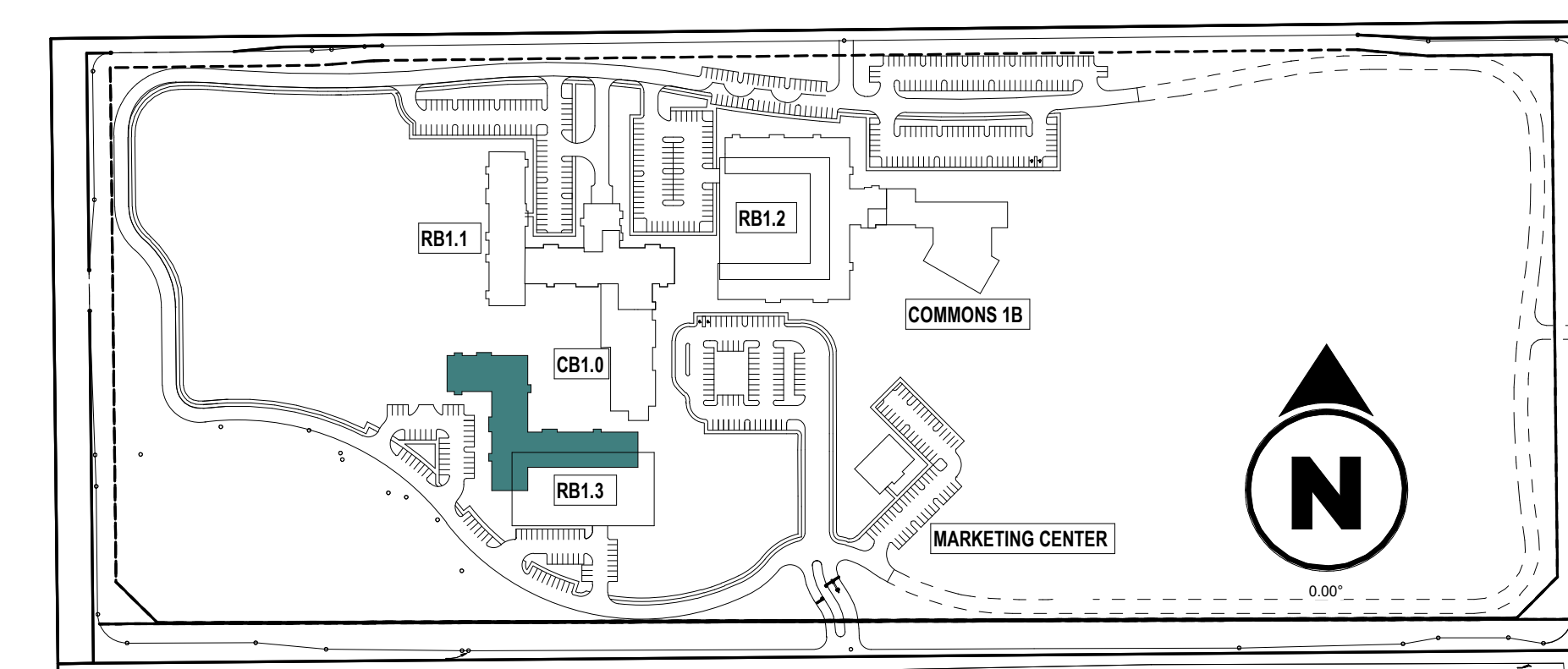

Erickson Senior Living Roseville
 MPP Stage 2 Floor Plan - RB1.3 Third-Sixth Level
 Sierra Vista, West Roseville, CA

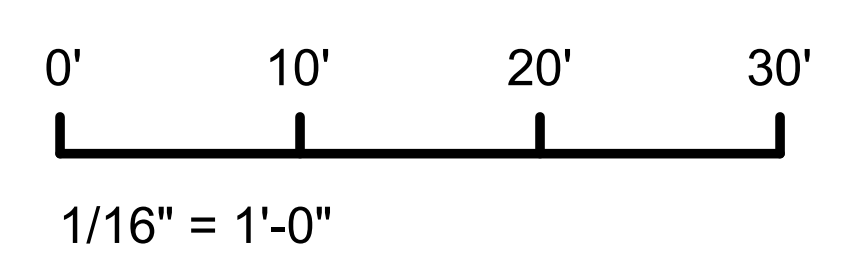

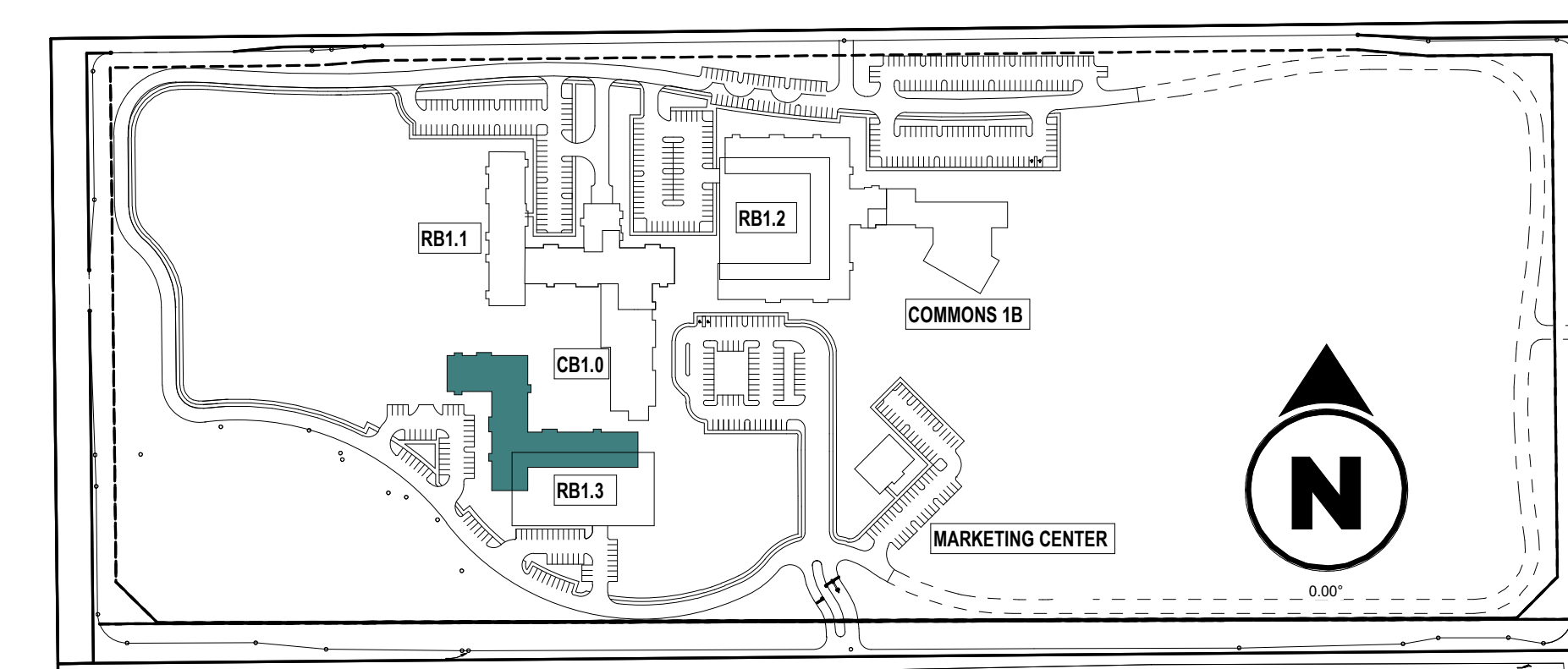
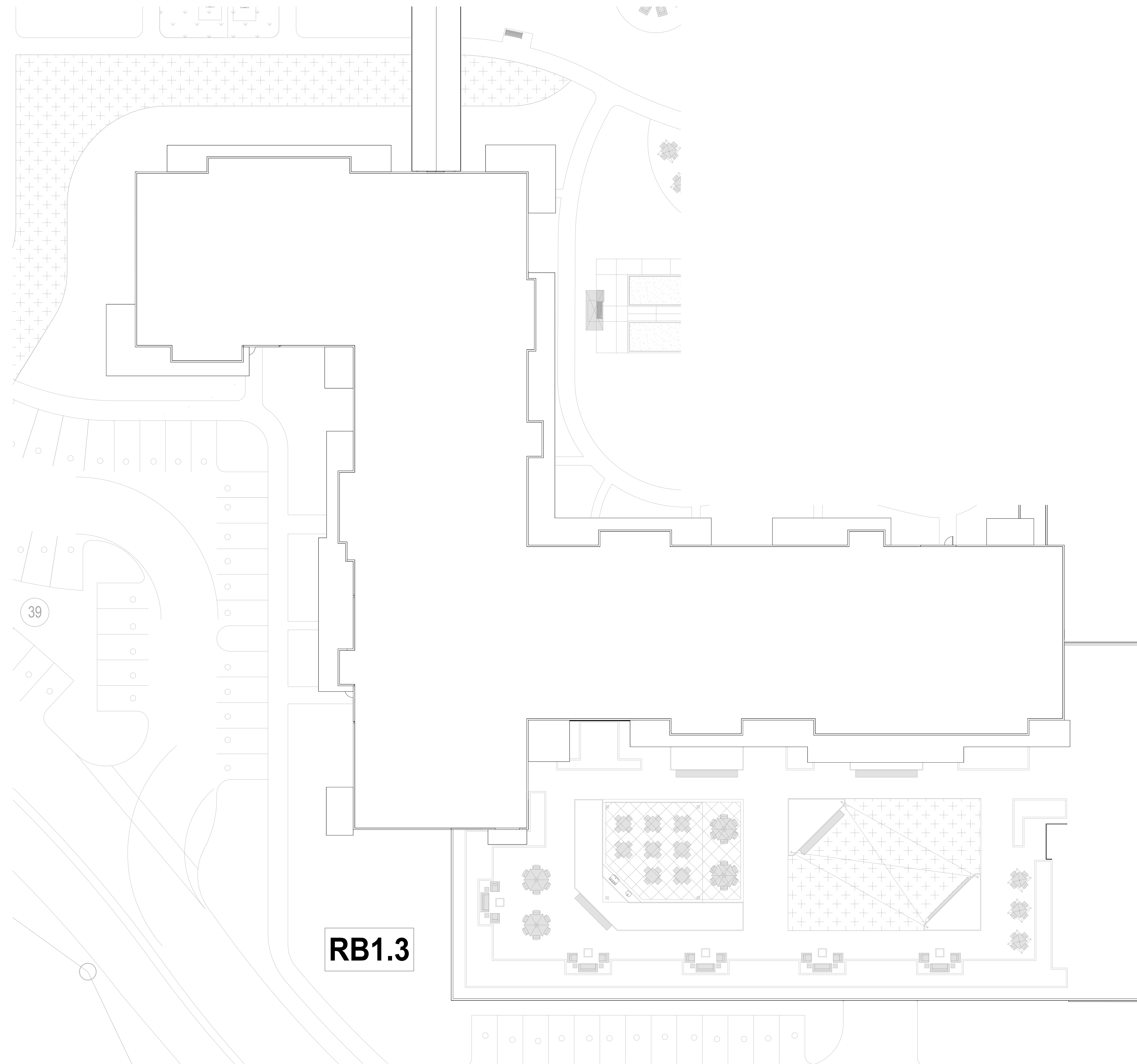

Erickson Senior Living Roseville
MPP Stage 2 Roof Plan - RB1.3
Sierra Vista, West Roseville, CA

0' 10' 20' 30'
1/16" = 1'-0"



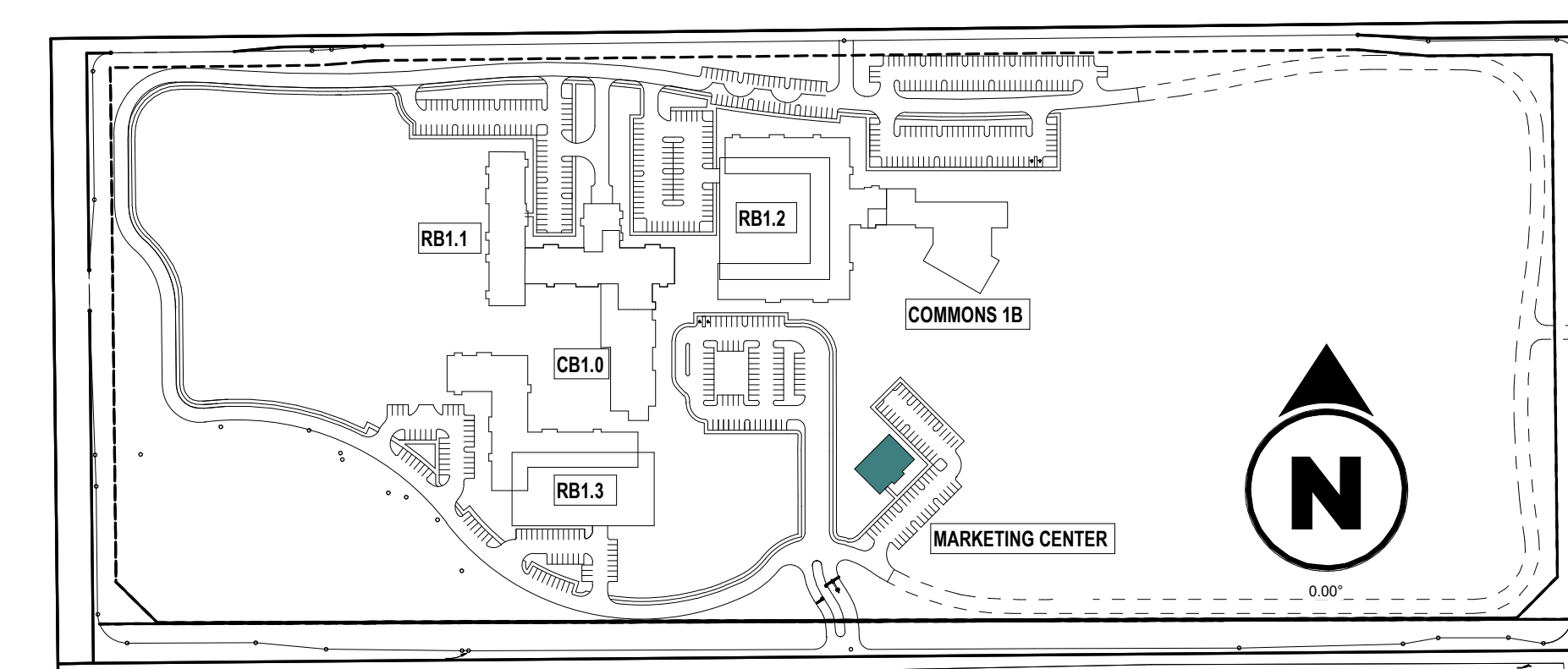
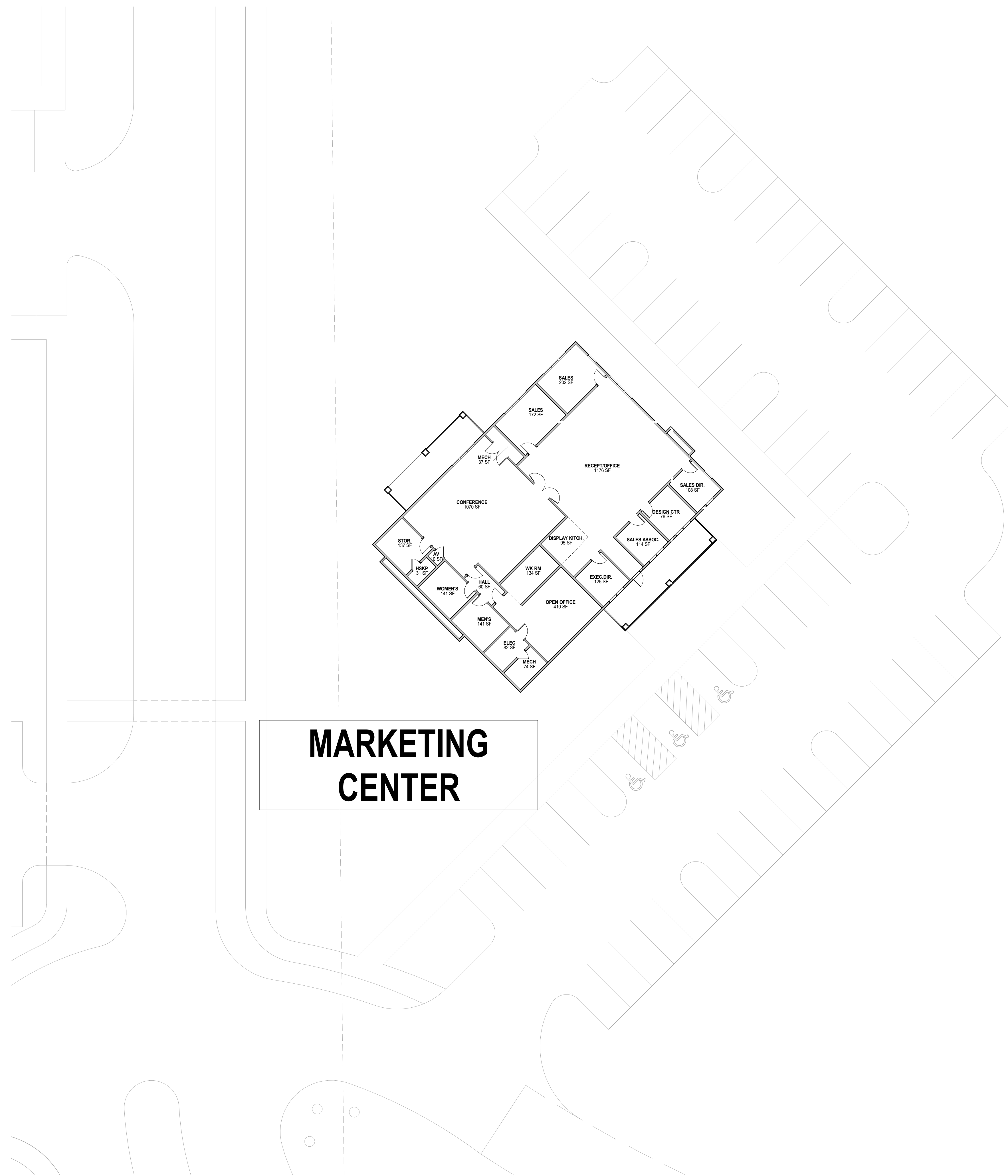

MARKETING CENTER

Erickson Senior Living Roseville

MPP Stage 2 Floor Plan - Marketing Center Ground Level

Sierra Vista, West Roseville, CA

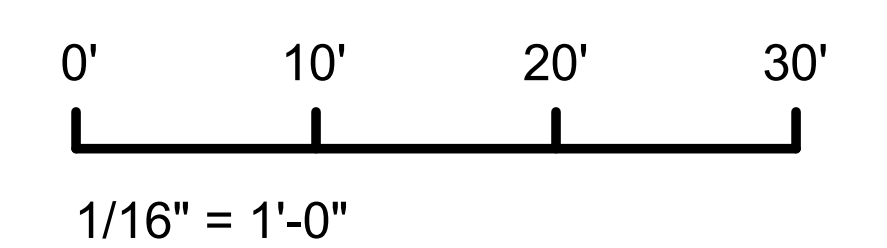

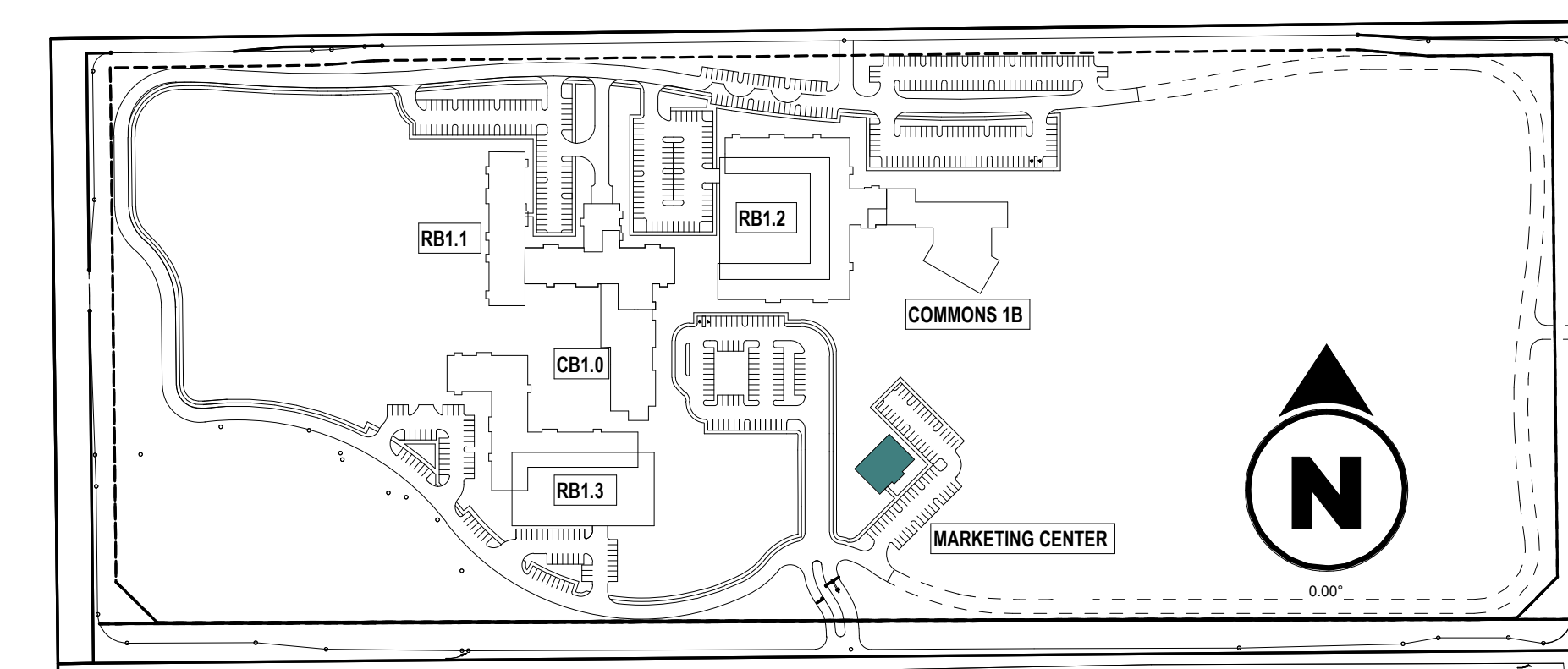

Erickson Senior Living Roseville
MPP Stage 2 Roof Plan - Marketing Center

Sierra Vista, West Roseville, CA

0' 10' 20' 30'
 1/16" = 1'-0"











AERIAL VIEW FROM SOUTHWEST



AERIAL VIEW FROM NORTH

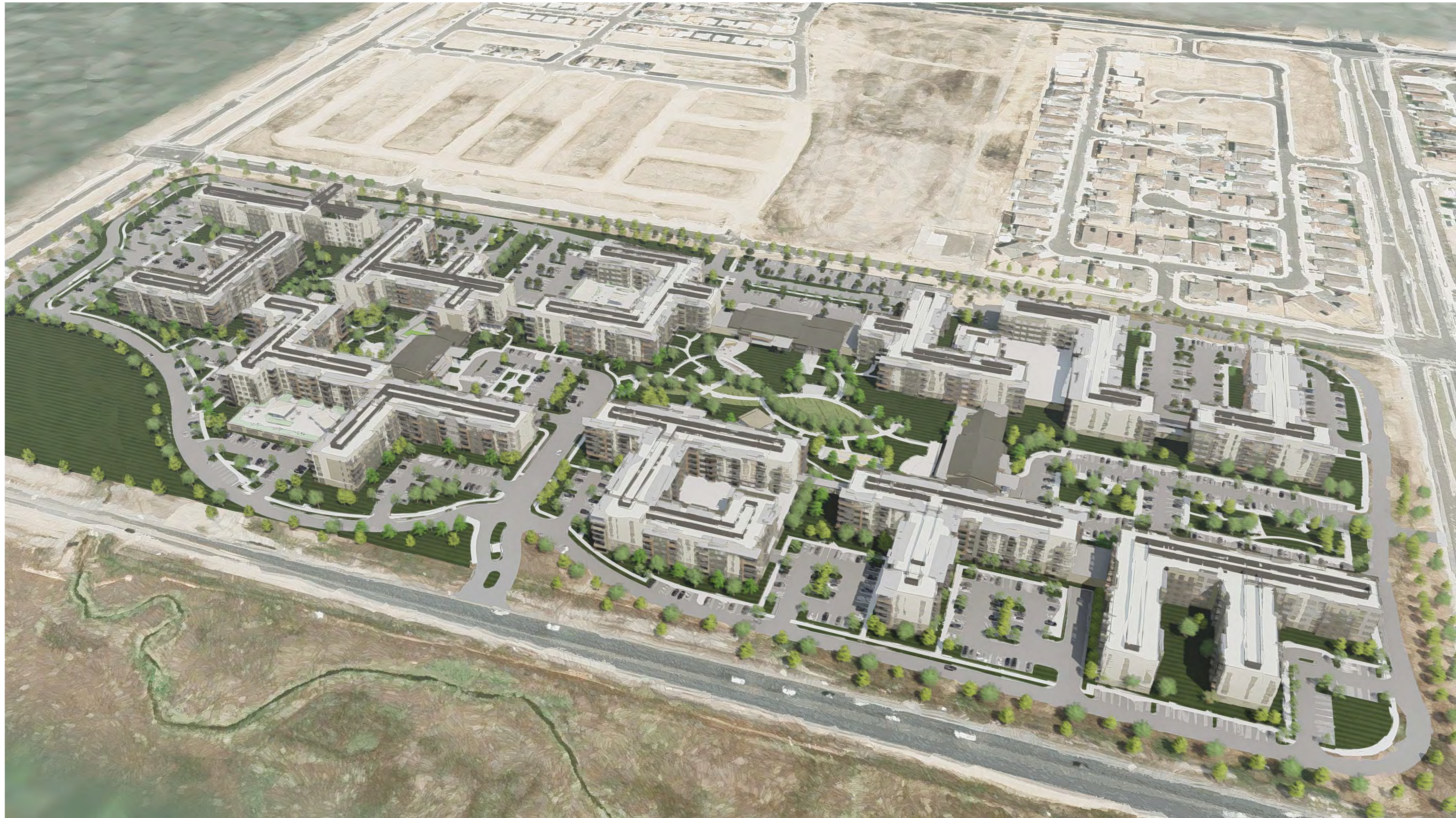

AERIAL VIEW FROM SOUTH



AERIAL VIEW FROM SOUTHEAST

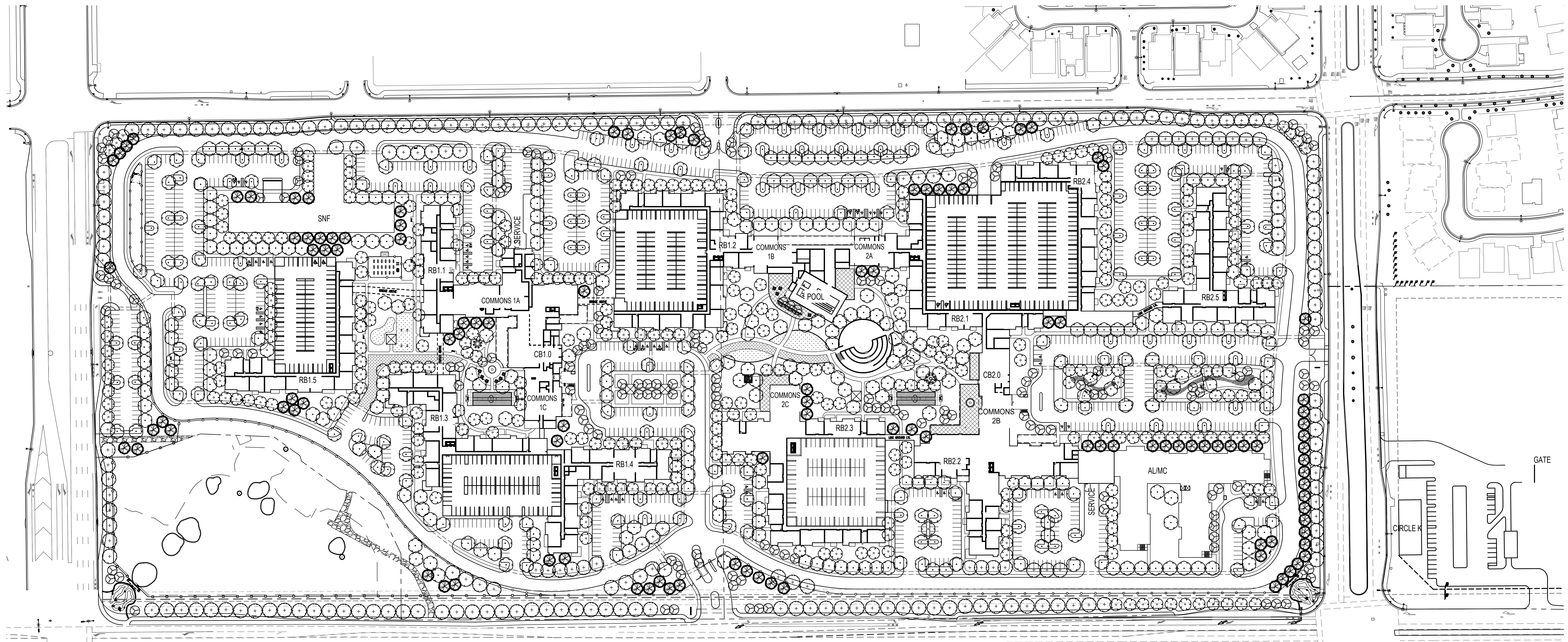

SHADE STUDY CALCULATIONS
PROJECT: ERICKSON SENIOR LIVING 11.18.2022

ENTIRE SITE (STAGE 1)			
STANDARD STALLS	1,164		314,280
COMPACT STALLS	0		0
HANDICAP STALLS	56		15,120
TOTAL PAVED PARKING AREA:			329,400
TOTAL SHADE REQUIRED:	50%		164,700
TOTAL SHADE PROVIDED:			237,926
TOTAL SHADE PERCENTAGE			72%

SYMBOL	PATTERN	QTY.	UNIT	IN S.F.	TOTAL S.F.
30' TO 35' TREES					
ACER R., PISTACHIA C., ULMUS C., ZELKOVA S.	30-F	83	X	962	79,846
	30-TQ	31	X	722	22,382
	30-H	193	X	481	92,833
	30-Q	74	X	240	17,760
25' TO 30' TREES					
ACER B., GINGKO B., KOELREUTERIA P., ZELKOVA S.	25-F	0	X	491	0
	25-TQ	0	X	369	0
	25-H	93	X	246	22,878
	25-Q	13	X	123	1,599
15' TO 20' TREES					
CERCIS O., LAGERSTROEMIA L., MAGNOLIA G., CHITALPA T.	15-F	0	X	314	0
	15-TQ	0	X	236	0
	15-H	4	X	157	628
	15-Q	0	X	79	0
TOTAL					237,926

PRELIMINARY LANDSCAPE NOTES

- A. STREETScape DESIGN INTENT - STREETScape WILL BE CONSISTENT WITH OTHER PROJECTS WITHIN THE SIERRA VISTA SPECIFIC PLAN AREA. WESTBROOK BLVD., SANTUCCI BLVD. & SIERRA VILLAGE DRIVE WILL UTILIZE A COMBINATION OF STREET TREES AND EVERGREEN SUBORDINATE TREES. BASELINE ROAD WILL HAVE TREES WHERE APPROPRIATE WHILE MAINTAINING CLEARANCE OF THE PG&E EASEMENT. USE OF EVERGREEN SHRUBS AND COLOR MAPPED PLANTING WILL BE INCORPORATED ALONG THE STREETScape. SHRUB MASSES WILL UTILIZE DROUGHT TOLERANT SPECIES WHERE APPROPRIATE.
- B. ENTRY TREATMENT - ENTRY WILL BE HIGHLIGHTED BY GROVE OF ACCENT TREES WITH LOW BACKGROUND PLANTING. MONUMENT SIGNAGE WILL MAIN ENTRY AT BASELINE ROAD. UNDER STORY WILL BE LOW AND CONFORMING TO AN UNDULATED GROUND CONTOUR, WHILE MAINTAINING SIGHT LINES. USE OF COLORFUL PLANT MATERIALS WILL FURTHER ENHANCE AND DEFINE THE ENTRIES, ALONG WITH DROUGHT TOLERANT SPECIES WHERE APPROPRIATE.
- C. BUILDING ZONE - FOCUS IS ON CONNECTIVITY FOR PEDESTRIANS. A VARIETY OF COLUMNAR AND SMALL SCALE TREES WITH LOW CONTRASTING SHRUB FORMS WILL BE USED TO ADD INTEREST, COLOR, AND TEXTURE. SEVERAL OUTDOOR PLAZA SPACES WITH TREE WELLS WILL BE INCORPORATED BETWEEN BUILDINGS.
- D. PARKING LOT INTENT - DESIGNATED TREES WILL PROVIDE A CANOPY OF SHADE. UNDER STORY PLANTINGS WITHIN THE PARKING LOT WILL CONSIST OF LOW SHRUBBERY AND/OR GROUND COVERS. PEDESTRIAN ACCESS IS PROVIDED FROM PARKING LOT TO ADJACENT EXISTING BIKE TRAIL ALONG THE SOUTH PROPERTY LINE.
- E. MONUMENT SIGNAGE CONSISTENT WITH THE SIERRA VISTA SPECIFIC PLAN WILL BE INSTALLED AT THE CORNERS OF BASELINE ROAD AND SANTUCCI BLVD. AND BASELINE ROAD AND WESTBROOK BLVD.
- F. PROJECT HAS A PLANNED WALKING PATH AROUND THE PERIMETER WITH INTERIOR WALKING LOOPS. MILEAGE SIGNAGE AND SHADED BENCHES WILL BE INCLUDED ALONG THE PATH.

CONCEPT PLANT SCHEDULE

- SHADE TREES**
 - ACER RUBRUM 'OCTOBER GLORY' / OCTOBER GLORY RED MAPLE (40'X35')
 - CELTIS OCCIDENTALIS / CHINESE HACKBERRY (40'X40')
 - PISTACHIA CHINENSIS / CHINESE PISTACHE (40'X40')
 - ZELKOVA SERRATA 'VILLAGE GREEN' / VILLAGE GREEN SAWLEAF ZELKOVA (50'X35')
- SCREEN TREES**
 - CEDRUS DEODARA / DEODAR CEDAR (60'X40")
 - PODOCARPUS GRACILIOR / FERN PINE (40'X20")
 - QUERCUS ILEX / HOLLY OAK (60'X40")
- ACCENT TREES**
 - CERCIS OCCIDENTALIS / WESTERN REDBUD (18'X18')
 - LAGERSTROEMIA INDICA 'FAURIEI' 'ARAPAHO' / RED CRAWPE MYRTLE (25'X20')
 - MAGNOLIA GRANDIFLORA 'LITTLE GEM' / LITTLE GEM DWARF MAGNOLIA (25'X15")
 - XCHITALPA TASHKENTENSIS 'PINK DAWN' / PINK DAWN CHITALPA (30'X25')
- SUBORDINATE TREES**
 - ACER BUERGERIANUM / TRIDENT MAPLE (25'X25')
 - GINGKO BILOBA 'PRINCETON SENTRY' / MAIDENHAIR TREE (40'X20')
 - KOELREUTERIA PANICULATA / GOLDEN RAIN TREE (35'X30')
 - ZELKOVA SERRATA 'MUSASHINDO' / MUSASHINO SAWLEAF ZELKOVA (40'X15')
- STREET TREE**
 - LIRIODENDRON TULIPIFERA / TULIP TREE (60'X40')
 - QUERCUS RUBRA / RED OAK (60'X45')



CONCEPT PLANT SCHEDULE

	SHADE TREES ACER RUBRUM 'OCTOBER GLORY' / OCTOBER GLORY RED MAPLE (40'X35') CELTIS OCCIDENTALIS / CHINESE HACKBERRY (40'X40') PISTACIA CHINENSIS / CHINESE PISTACHE (40'X40') ZELKOVA SERRATA 'VILLAGE GREEN' / VILLAGE GREEN SAWLEAF ZELKOVA (50'X35')
	SCREEN TREES CEDRUS DEODARA / DEODAR CEDAR (60'X40") PODOCARPUS GRACILIOR / FERN PINE (40'X20") QUERCUS ILEX / HOLLY OAK (60'X40")
	ACCENT TREES CERCIS OCCIDENTALIS / WESTERN REDBUD (18'X18") LAGERSTROEMIA INDICA X FAURIEI 'ARAPAHO' / RED CRAPE MYRTLE (25'X20") MAGNOLIA GRANDIFLORA 'LITTLE GEM' / LITTLE GEM DWARF MAGNOLIA (25'X15") X CHITALPA TASHKENTENSIS 'PINK DAWN' / PINK DAWN CHITALPA (30'X25")
	SUBORDINATE TREES ACER BUERGERIANUM / TRIDENT MAPLE (25'X25") GINKGO BILOBA 'PRINCETON SENTRY' / MAIDENHAIR TREE (40'X20") KOELREUTERIA PANICULATA / GOLDEN RAIN TREE (35'X30") ZELKOVA SERRATA 'MUSASHINO' / MUSASHINO SAWLEAF ZELKOVA (40'X15")
	STREET TREE LIRIODENDRON TULIPIFERA / TULIP TREE (60'X40") QUERCUS RUBRA / RED OAK (60'X45")

REFERENCE NOTES SCHEDULE

SYMBOL	DESCRIPTION
1	PROPOSED BUILDINGS - SEE ARCHITECTURAL PLANS.
2	PROPOSED MAIN ENTRY WITH GATE HOUSE.
3	PROPOSED SECONDARY ENTRY.
4	PROPOSED STORMWATER BASINS - SEE CIVIL PLANS.
5	PROPOSED SVSP MONUMENT SIGNAGE PER CITY OF ROSEVILLE SVSP DESIGN GUIDELINES.
6	PROPOSED PROJECT MONUMENT SIGN (TYP. OF 3)
7	PROPOSED FLAG POLES (TYP. OF 3)
8	PROPOSED SEATING / AMENITY AREA ON ROOF DECK.
9	PROPOSED OUTDOOR DINING PATIOS.
10	PROPOSED SIDEWALKS.
11	PROPOSED SHORT TERM BIKE RACKS.
12	PROPOSED DOG PARK.
13	PROPOSED COMMUNITY GARDEN.
14	PROPOSED PUTTING GREEN.
15	PROPOSED FIRE PIT.
16	PROPOSED SEATING AREA WITH SHADE SHELTER.
17	PROPOSED BENCHES ON PERIMETER WALKING PATH.
18	PROPOSED OPEN TURF AREAS.
19	PROPOSED BOCCIE COURTS.
20	PROPOSED TABLE AND CHAIRS WITH UMBRELLAS.
21	PROPOSED SYNTHETIC TURF ON PAVERS FOR FIRE ACCESS.
22	PROPOSED SUN DECK WITH FURNITURE.
23	PROPOSED WATER FEATURE.
24	PROPOSED AMPHITHEATER.
25	PROPOSED OPEN METAL FENCE.
26	PROPOSED DRY CREEK BED.

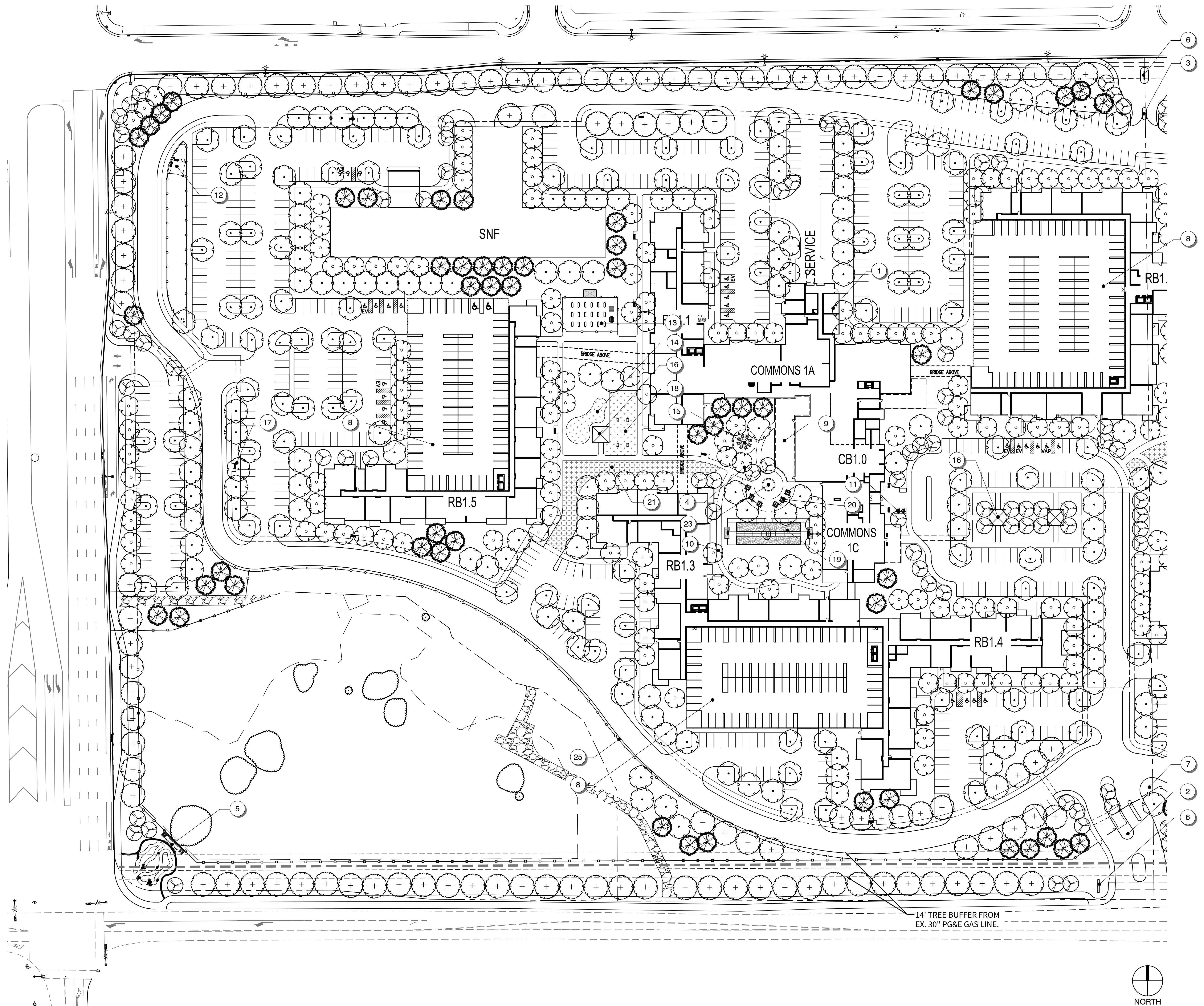

FUHRMAN LEAMY LAND GROUP
DESIGN · SERVICE · SOLUTIONS
2140 PROFESSIONAL DRIVE, SUITE 115 ROSEVILLE, CA 95661
(916) 783-5263 info@fllandgroup.com

CONCEPT PLANT SCHEDULE

	SHADE TREES ACER RUBRUM 'OCTOBER GLORY' / OCTOBER GLORY RED MAPLE (40'X35') CELTIS OCCIDENTALIS / CHINESE HACKBERRY (40'X40') PISTACIA CHINENSIS / CHINESE PISTACHE (40'X40') ZELKOVA SERRATA 'VILLAGE GREEN' / VILLAGE GREEN SAWLEAF ZELKOVA (50'X35')
	SCREEN TREES CEDRUS DEODARA / DEODAR CEDAR (60'X40") PODOCARPUS GRACILIOR / FERN PINE (40'X20") QUERCUS ILEX / HOLLY OAK (60'X40")
	ACCENT TREES CERCIS OCCIDENTALIS / WESTERN REDBUD (18'X18") LAGERSTROEMIA INDICA X FAURIEI 'ARAPAHO' / RED CRAPE MYRTLE (25'X20") MAGNOLIA GRANDIFLORA 'LITTLE GEM' / LITTLE GEM DWARF MAGNOLIA (25'X15") X CHITALPA TASHKENTENSIS 'PINK DAWN' / PINK DAWN CHITALPA (30'X25")
	SUBORDINATE TREES ACER BUERGERIANUM / TRIDENT MAPLE (25'X25") GINKGO BILOBA 'PRINCETON SENTINEL' / MAIDENHAIR TREE (40'X20") KOELREUTERIA PANICULATA / GOLDEN RAIN TREE (35'X30") ZELKOVA SERRATA 'MUSASHINO' / MUSASHINO SAWLEAF ZELKOVA (40'X15")
	STREET TREE LIRIODENDRON TULIPIFERA / TULIP TREE (60'X40") QUERCUS RUBRA / RED OAK (60'X45")

REFERENCE NOTES SCHEDULE

SYMBOL	DESCRIPTION
1	PROPOSED BUILDINGS - SEE ARCHITECTURAL PLANS.
2	PROPOSED MAIN ENTRY WITH GATE HOUSE.
3	PROPOSED SECONDARY ENTRY.
4	PROPOSED STORMWATER BASINS - SEE CIVIL PLANS.
5	PROPOSED SVSP MONUMENT SIGNAGE PER CITY OF ROSEVILLE SVSP DESIGN GUIDELINES.
6	PROPOSED PROJECT MONUMENT SIGN (TYP. OF 3)
7	PROPOSED FLAG POLES (TYP. OF 3)
8	PROPOSED SEATING / AMENITY AREA ON ROOF DECK.
9	PROPOSED OUTDOOR DINING PATIOS.
10	PROPOSED SIDEWALKS.
11	PROPOSED SHORT TERM BIKE RACKS.
12	PROPOSED DOG PARK.
13	PROPOSED COMMUNITY GARDEN.
14	PROPOSED PUTTING GREEN.
15	PROPOSED FIRE PIT.
16	PROPOSED SEATING AREA WITH SHADE SHELTER.
17	PROPOSED BENCHES ON PERIMETER WALKING PATH.
18	PROPOSED OPEN TURF AREAS.
19	PROPOSED BOCCIE COURTS.
20	PROPOSED TABLE AND CHAIRS WITH UMBRELLAS.
21	PROPOSED SYNTHETIC TURF ON PAVERS FOR FIRE ACCESS.
22	PROPOSED SUN DECK WITH FURNITURE.
23	PROPOSED WATER FEATURE.
24	PROPOSED AMPHITHEATER.
25	PROPOSED OPEN METAL FENCE.
26	PROPOSED DRY CREEK BED.

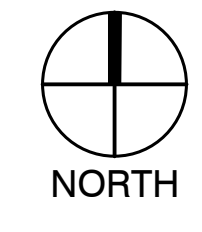
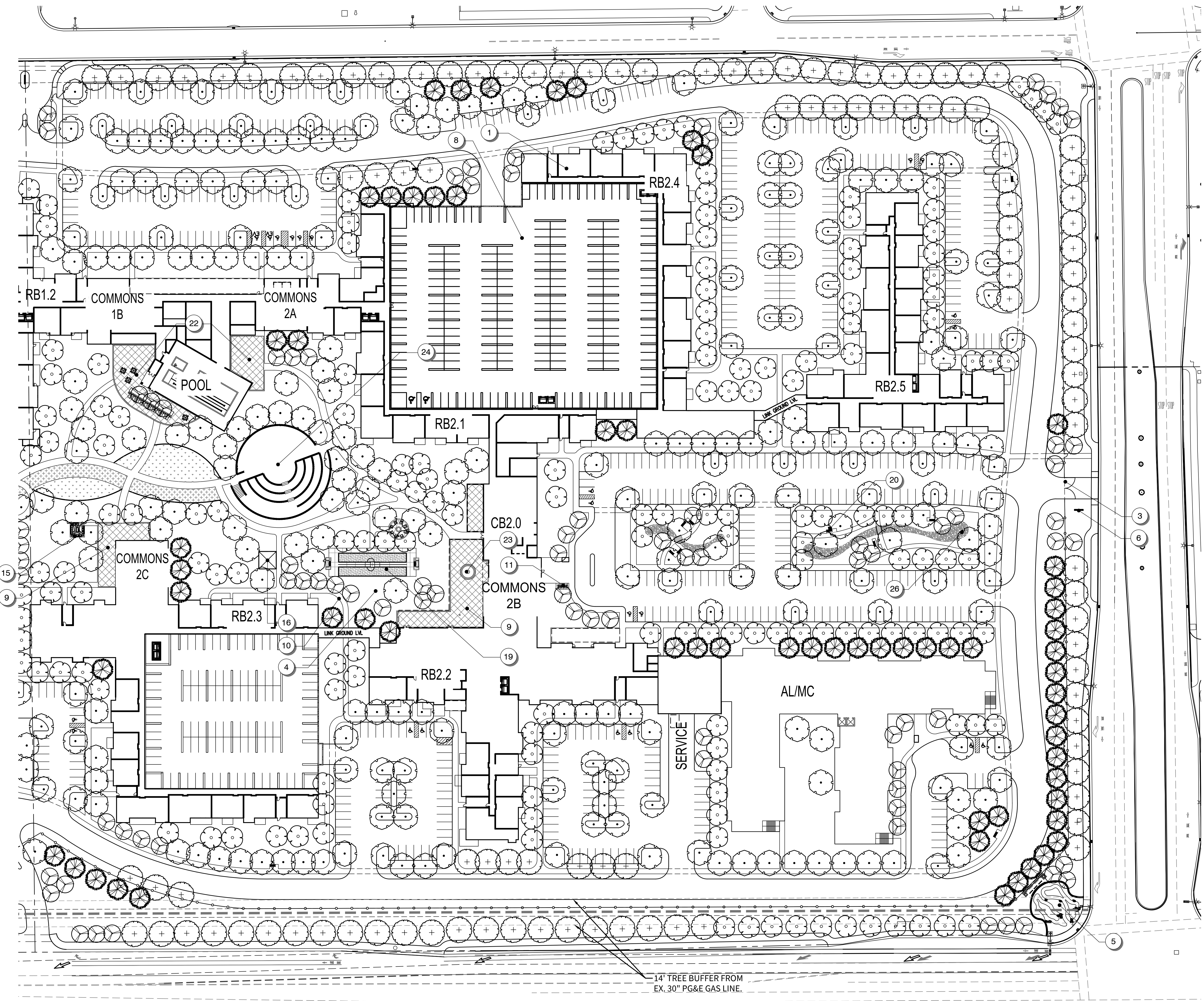

FUHRMAN LEAMY LAND GROUP
DESIGN · SERVICE · SOLUTIONS
2140 PROFESSIONAL DRIVE, SUITE 115 ROSEVILLE, CA 95661
(916) 783-5263 info@fllandgroup.com

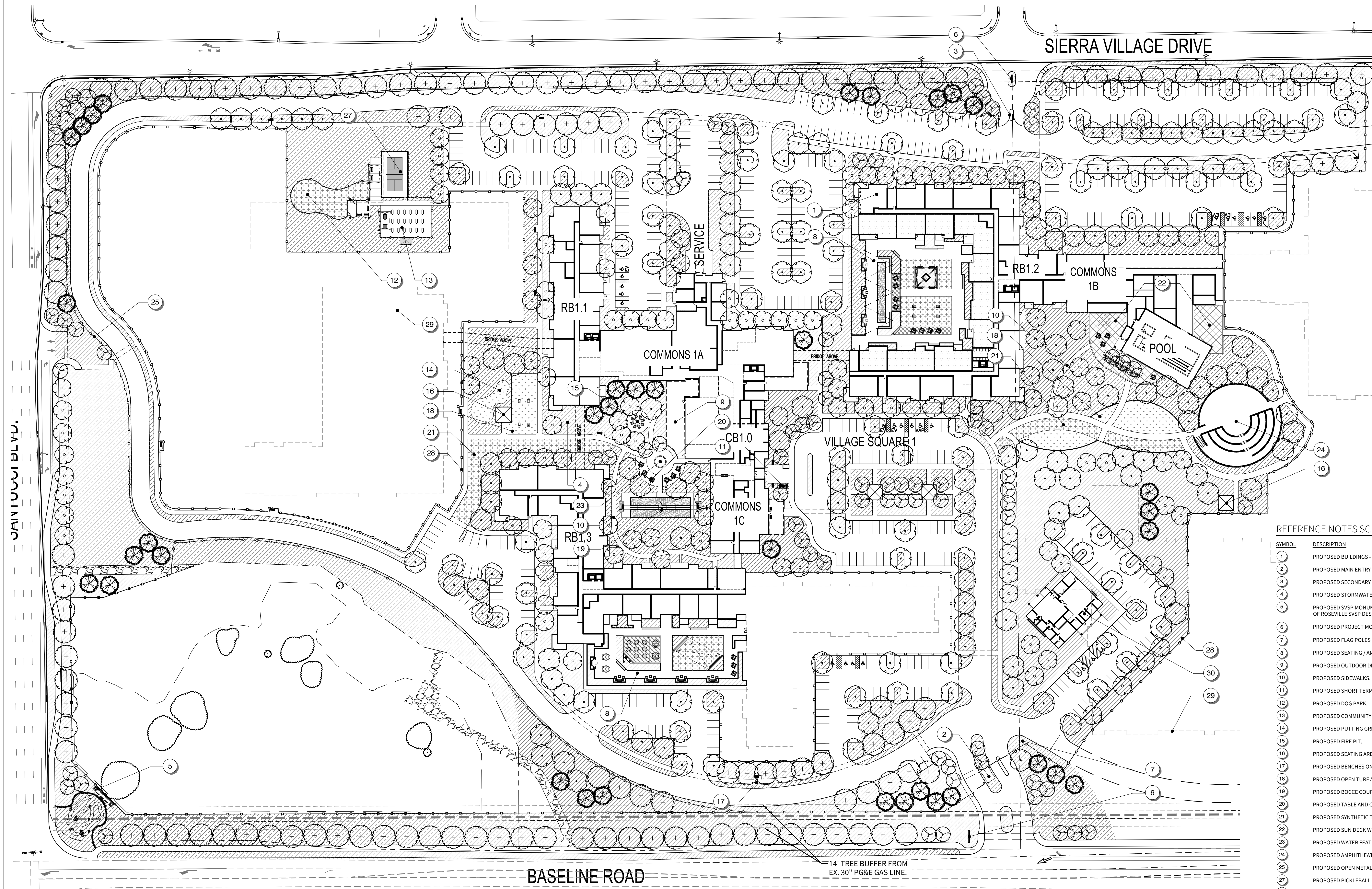

REFERENCE NOTES SCHEDULE

SYMBOL	DESCRIPTION
1	PROPOSED BUILDINGS - SEE ARCHITECTURAL PLANS.
2	PROPOSED MAIN ENTRY WITH GATE HOUSE.
3	PROPOSED SECONDARY ENTRY.
4	PROPOSED STORMWATER BASINS - SEE CIVIL PLANS.
5	PROPOSED SVSP MONUMENT SIGNAGE PER CITY OF ROSEVILLE SVSP DESIGN GUIDELINES.
6	PROPOSED PROJECT MONUMENT SIGN (TYP. OF 3)
7	PROPOSED FLAG POLES (TYP. OF 3)
8	PROPOSED SEATING / AMENITY AREA ON ROOF DECK.
9	PROPOSED OUTDOOR DINING PATIOS.
10	PROPOSED SIDEWALKS.
11	PROPOSED SHORT TERM BIKE RACKS.
12	PROPOSED DOG PARK.
13	PROPOSED COMMUNITY GARDEN.
14	PROPOSED PUTTING GREEN.
15	PROPOSED FIRE PIT.
16	PROPOSED SEATING AREA WITH SHADE SHELTER.
17	PROPOSED BENCHES ON PERIMETER WALKING PATH.
18	PROPOSED OPEN TURF AREAS.
19	PROPOSED BOCCIE COURTS.
20	PROPOSED TABLE AND CHAIRS WITH UMBRELLAS.
21	PROPOSED SYNTHETIC TURF ON PAVERS FOR FIRE ACCESS.
22	PROPOSED SUN DECK WITH FURNITURE.
23	PROPOSED WATER FEATURE.
24	PROPOSED AMPHITHEATER.
25	PROPOSED OPEN METAL FENCE.
27	PROPOSED PICKLEBALL COURT.
28	PROPOSED CONSTRUCTION FENCE LOCATION.
29	PROPOSED FUTURE BUILDING.
30	PROPOSED MARKETING CENTER.



SHADE STUDY CALCULATIONS

PROJECT: ERICKSON SENIOR LIVING 11.18.2022

PHASE 1 & 1A (STAGE 2)	STANDARD STALLS	COMPACT STALLS	HANDICAP STALLS	TOTAL PAVED PARKING AREA:	TOTAL SHADE REQUIRED:	TOTAL SHADE PROVIDED:	TOTAL SHADE PERCENTAGE
	555	0	28	157,410	50%	90,874	58%

SYMBOL	PATTERN	QTY.	UNIT	IN S.F.	TOTAL S.F.
30 TO 35' TREES					
ACER R., PISTACHIA C., ULMUS C.	30-F	37	X	962	35,594
ZELKOVA S.	30-TQ	15	X	722	10,830
	30-H	70	X	481	33,670
	30-Q	30	X	240	7,200
25' TO 30' TREES					
ACER B., GINKGO B.	25-F	0	X	491	0
KOELREUTERIA P., ZELKOVA S.	25-TQ	0	X	369	0
	25-H	10	X	246	2,460
	25-Q	4	X	123	492
15' TO 20' TREES					
CERCIS O., LAGERSTROEMIA I.	15-F	0	X	314	0
MAGNOLIA G., CHITALPA T.	15-TQ	0	X	236	0
	15-H	4	X	157	628
	15-Q	0	X	79	0
TOTAL					90,874

CONCEPT PLANT SCHEDULE

- SHADE TREES**
 - ACER RUBRUM 'OCTOBER GLORY' / OCTOBER GLORY RED MAPLE (40'X35')
 - CELTIS OCCIDENTALIS / CHINESE HACKBERRY (40'X40')
 - PISTACHIA CHINENSIS / CHINESE PISTACHE (40'X40')
 - ZELKOVA SERRATA 'VILLAGE GREEN' / VILLAGE GREEN SAWLEAF ZELKOVA (50'X35')
- SCREEN TREES**
 - CEDRUS DEODARA / DEODAR CEDAR (60'X40")
 - PODOCARPUS GRACILIOR / FERN PINE (40'X20")
 - QUERCUS ILEX / HOLLY OAK (60'X40")
- ACCENT TREES**
 - CERCIS OCCIDENTALIS / WESTERN REDBUD (18'X18')
 - LAGERSTROEMIA INDICA X FAURIEI 'ARAPAHO' / RED CRAPE MYRTLE (25'X20')
 - MAGNOLIA GRANDIFLORA 'LITTLE GEM' / LITTLE GEM DWARF MAGNOLIA (25'X15")
 - X CHITALPA TASHKENTENSIS 'PINK DAWN' / PINK DAWN CHITALPA (30'X25')
- SUBORDINATE TREES**
 - ACER BUERGERIANUM / TRIDENT MAPLE (25'X25')
 - GINKGO BILOBA 'PRINCETON SENTRY' / MAIDENHAIR TREE (40'X20')
 - KOELREUTERIA PANICULATA / GOLDEN RAIN TREE (35'X30')
 - ZELKOVA SERRATA 'MUSASHINO' / MUSASHINO SAWLEAF ZELKOVA (40'X15')
- STREET TREE**
 - LIRIODENDRON TULIPIFERA / TULIP TREE (60'X40')
 - QUERCUS RUBRA / RED OAK (60'X45')
- SHRUB AREA**
 - ACACIA COGNATA 'ACCOG01' / COUSIN ITT LITTLE RIVER WATTLE (3'X5')
 - CALLISTEMON VIMINALIS 'LITTLE JOHN' / LITTLE JOHN WEeping BOTTLEBRUSH (3'X3')
 - CISTUS X PURPUREUS / ORCHID ROCKROSE (4'X4')
 - DIANELLA TASMANICA 'VARIGATA' / VARIGATED FLAX LILY (4'X3')
 - DIETES BICOLOR / FORTNIGHT LILY (3'X3')
 - ELAEAGARPUS DECIPENS 'MONPROUD' / JAPANESE BLUEBERRY TREE DWARF (10'X8')
 - GREVILLEA X 'NOELLI' / NOEL GREVILLEA (4'X5')
 - HYPERICUM X MOSERANUM / GOLD FLOWER (3'X3')
 - MUHLENBERGIA RIGENS / DEER GRASS (4'X4')
 - NANDINA DOMESTICA 'GULF STREAM' TM / GULF STREAM HEAVENLY BAMBOO (4'X2')
 - PRUNUS CAROLINIANA 'MONUS' TM / BRIGHT 'N TIGHT LAUREL CHERRY (8'X6')
 - RHAMNUS CALIFORNICA 'MOUND SAN BRUNO' / CALIFORNIA COFFEEBERRY (5'X8')
 - RHAPHIOLEPIS UMBELLATA / YEDDA HAWTHORN (5'X5')
 - RHAPHIOLEPIS UMBELLATA 'MINOR' / DWARF YEDDA HAWTHORNE (4'X4')
- GROUND COVER AREA**
 - ARCTOSTAPHYLOS X 'EMERALD CARPET' / EMERALD CARPET MANZANITA (12"X5')
 - COPROSMA KIRKII 'VERDE VISTA' / VERDE VISTA CREEPING COPROSMAT (3'X6')
 - COTONEASTER DAMMERI 'LOWFAST' / LOWFAST BEARBERRY COTONEASTER (8"X6')
 - LOMANDRA LONGIFOLIA 'BREEZE' / BREEZE MAT RUSH (3'X3')
 - TEUCRIUM X LUCIDRYS PROSTRATUM / GERMANDER (6"X3')
- TURF AREA**
 - TURF SOD BOLERO PLUS / FESCUE BLEND
- TURF - SYNTHETIC**

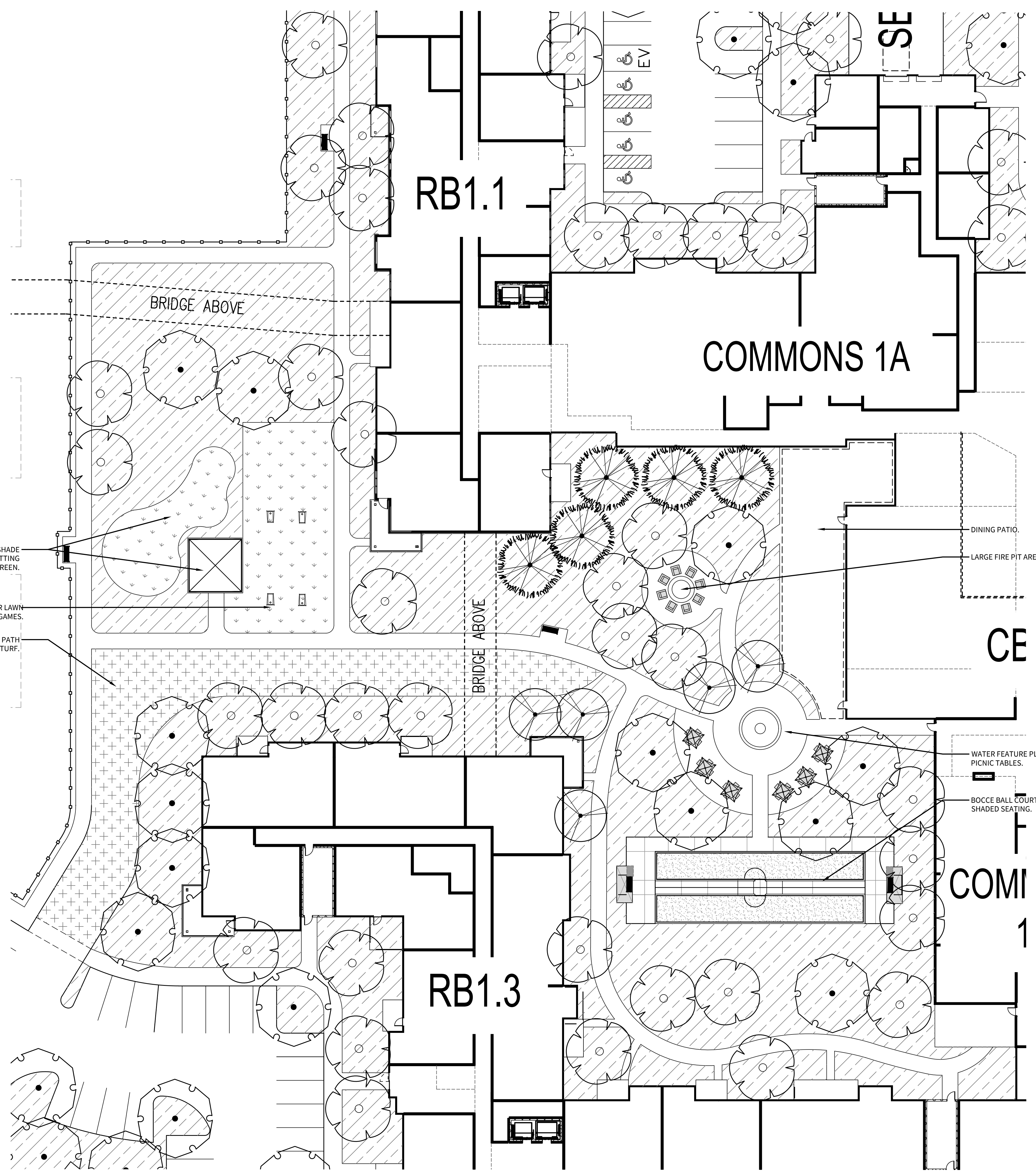

A COMMONS 1A & 1C COURTYARD
1" = 20'

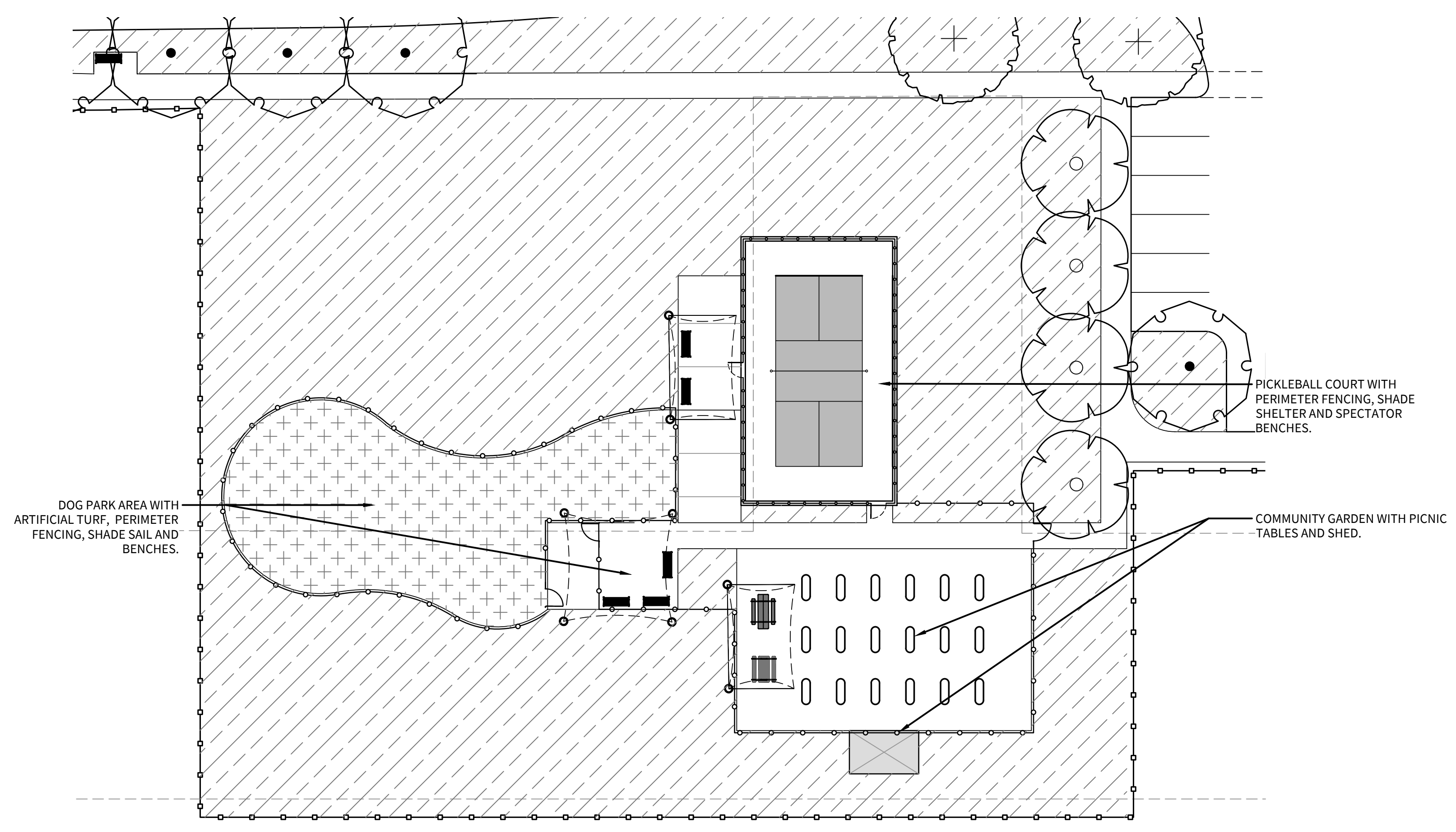

B PICKLEBALL, DOG PARK & COMMUNITY GARDEN
1" = 20'

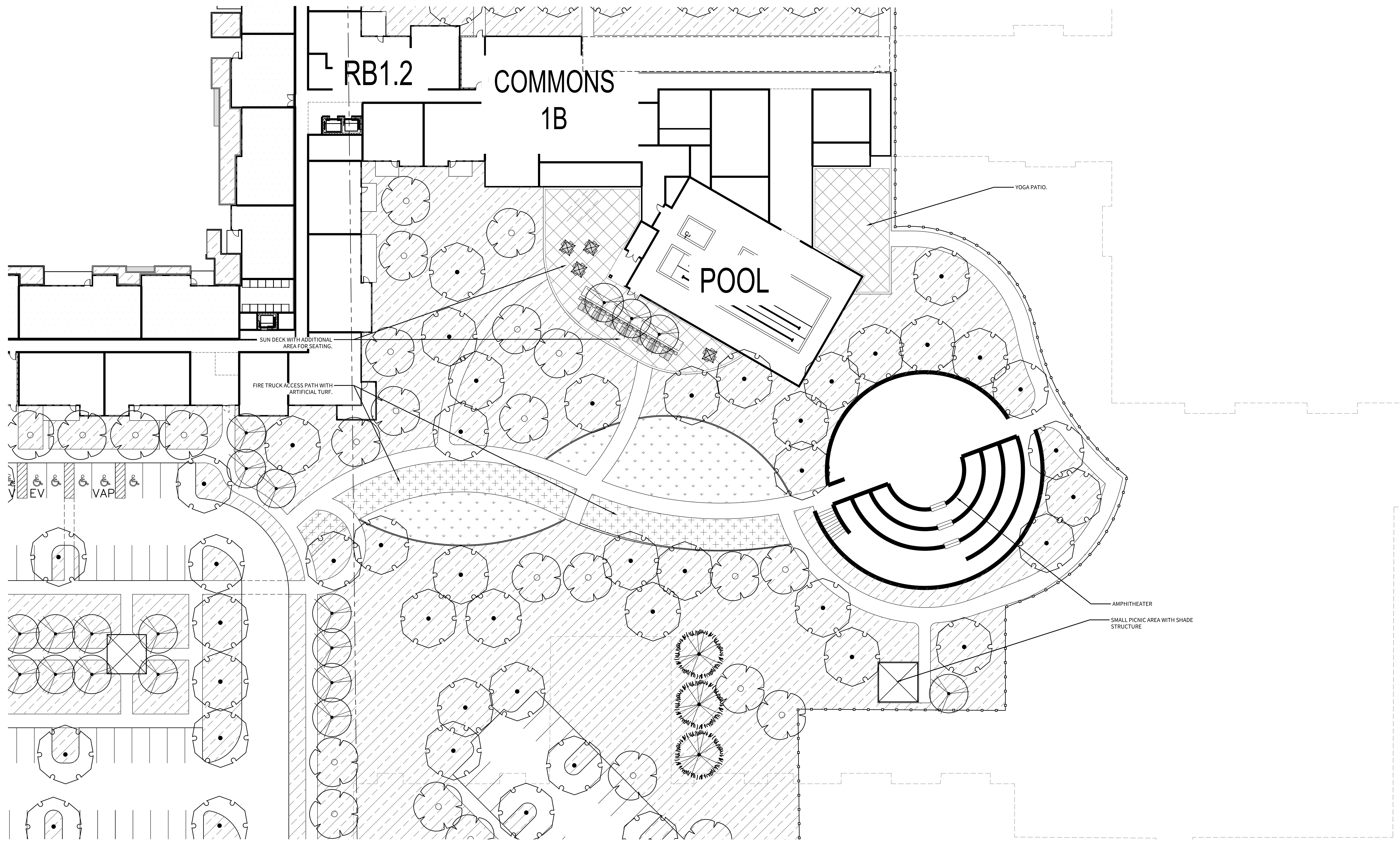

A COMMONS 1B COURTYARD
1" = 20'

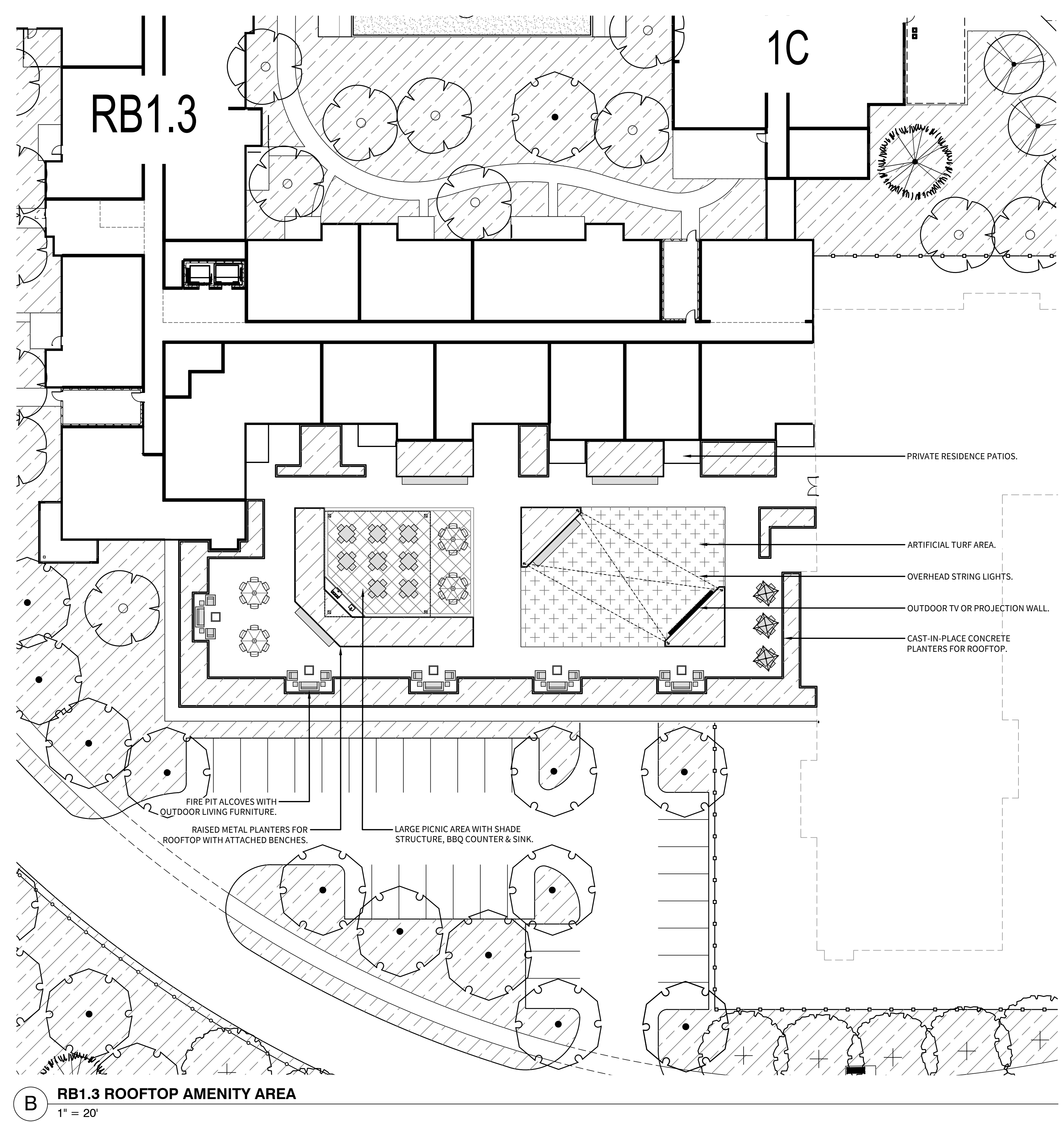
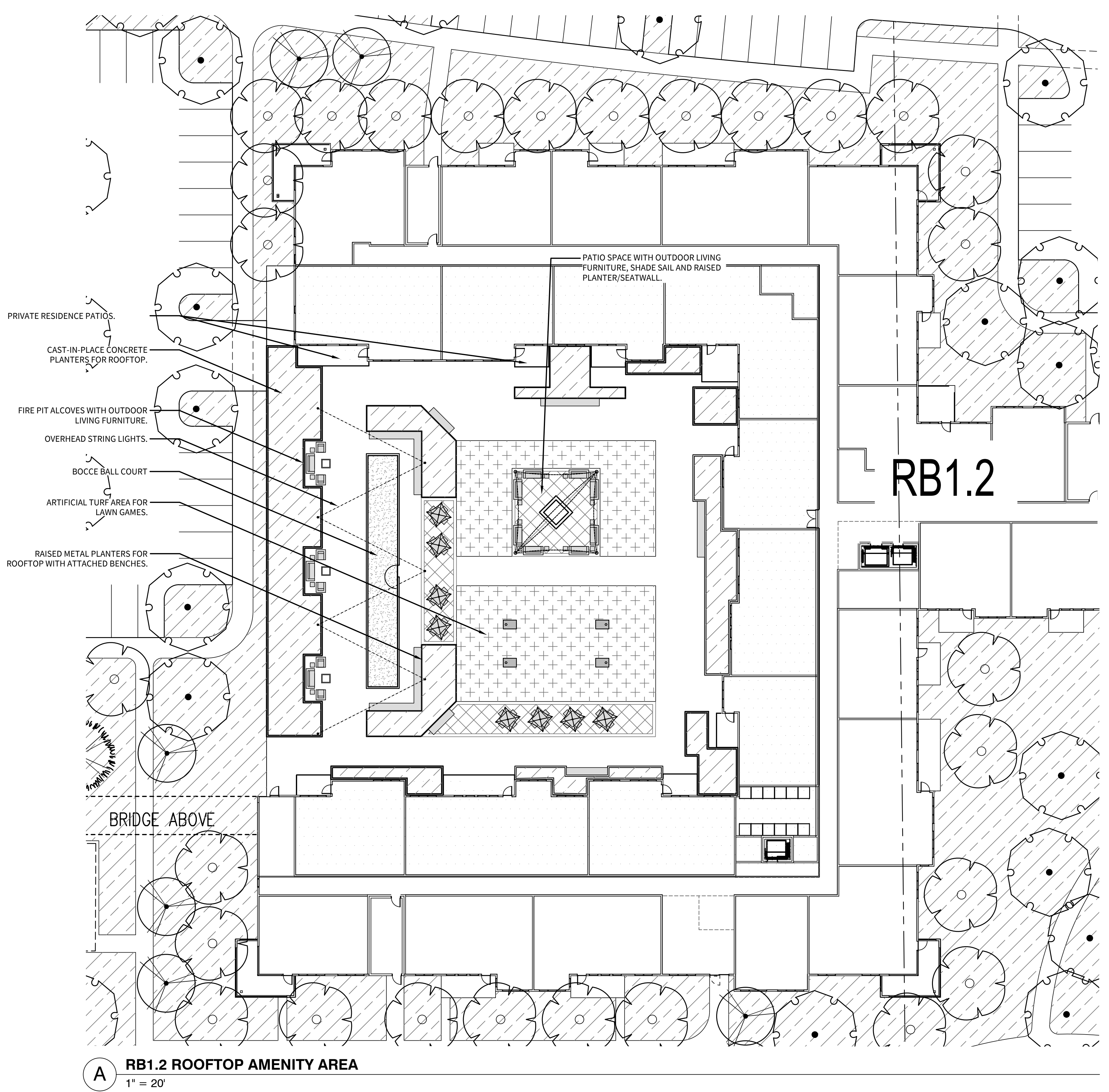

SIERRA VILLAGE DRIVE

SANTUCCI BOULEVARD

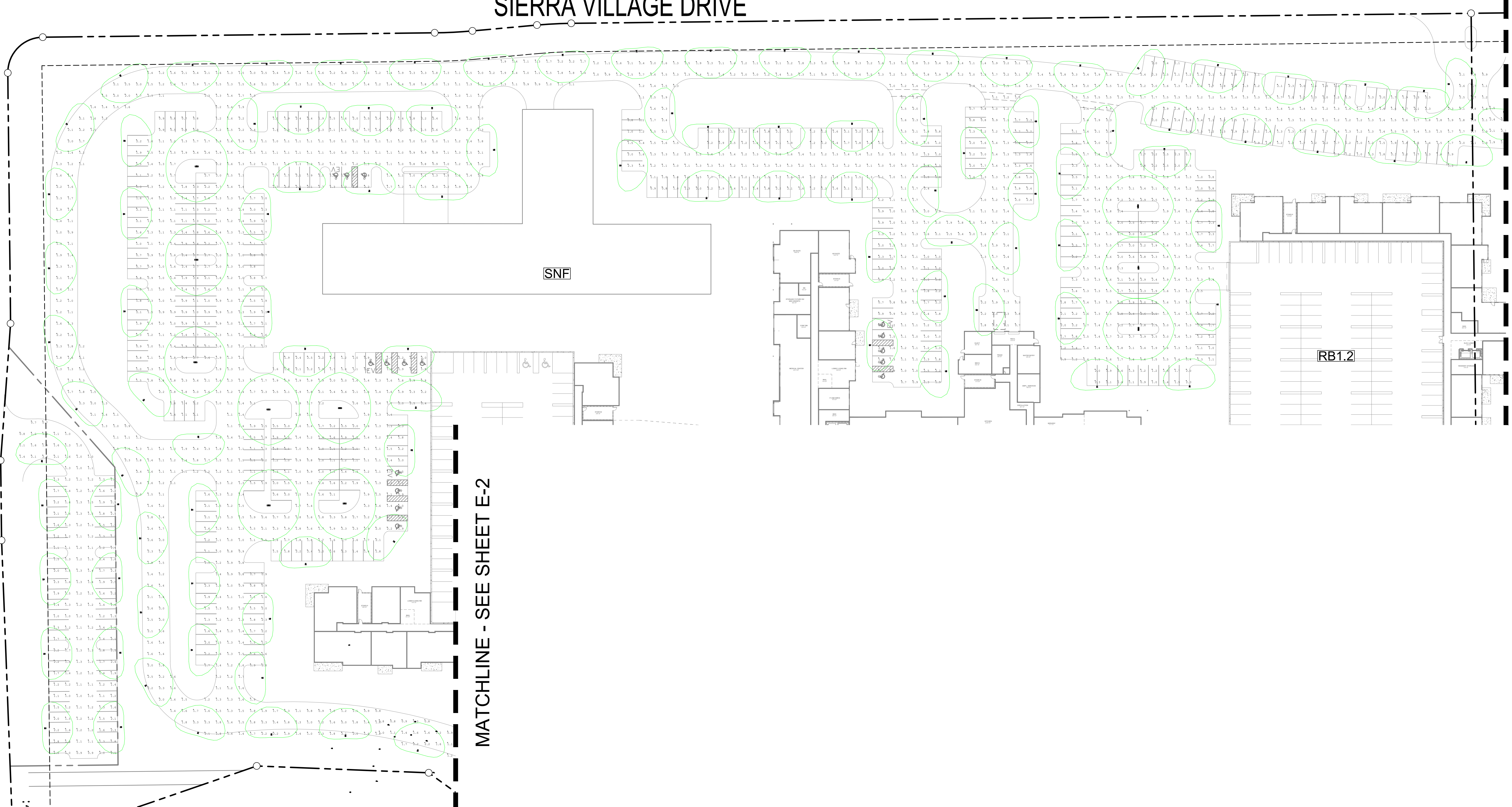

MATCHLINE - SEE SHEET E-2

MATCHLINE - SEE SHEET E-3

Label	CalcType	Units	Avg	Max	Min	Avg/Min	Max/Min
Park n Ride	Illuminance	Fc	1.44	2.5	0.7	2.06	3.57
Parking 1	Illuminance	Fc	1.37	2.8	0.7	1.96	4.00
Parking 2	Illuminance	Fc	1.57	2.9	0.8	1.96	3.63
Parking 3	Illuminance	Fc	1.44	2.6	0.7	2.06	3.71
Parking 4	Illuminance	Fc	1.68	3.0	0.7	2.40	4.29
Parking 5	Illuminance	Fc	1.47	2.8	0.7	2.10	4.00
Parking 6	Illuminance	Fc	1.42	2.6	0.7	2.03	3.71
Parking 7	Illuminance	Fc	1.52	2.8	0.7	2.17	4.00
Parking 8	Illuminance	Fc	1.56	2.9	0.7	2.23	4.14

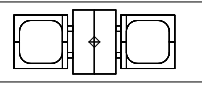
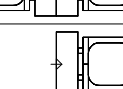
Symbol	Qty	Label	Arrangement	Description	LLF	Luminaire Lumens
	22	37W LED_D	Back-Back	KH15QC1X37U4KC	0.920	4653
	319	37W LED	Single	KH15QC1X37U4KC	0.920	4653

6000 BASELINE ROAD
ERICKSON SENIOR LIVING ROSEVILLE

PHOTOMETRIC PLAN - E-1

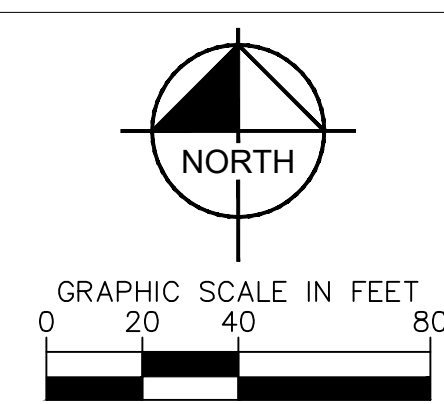

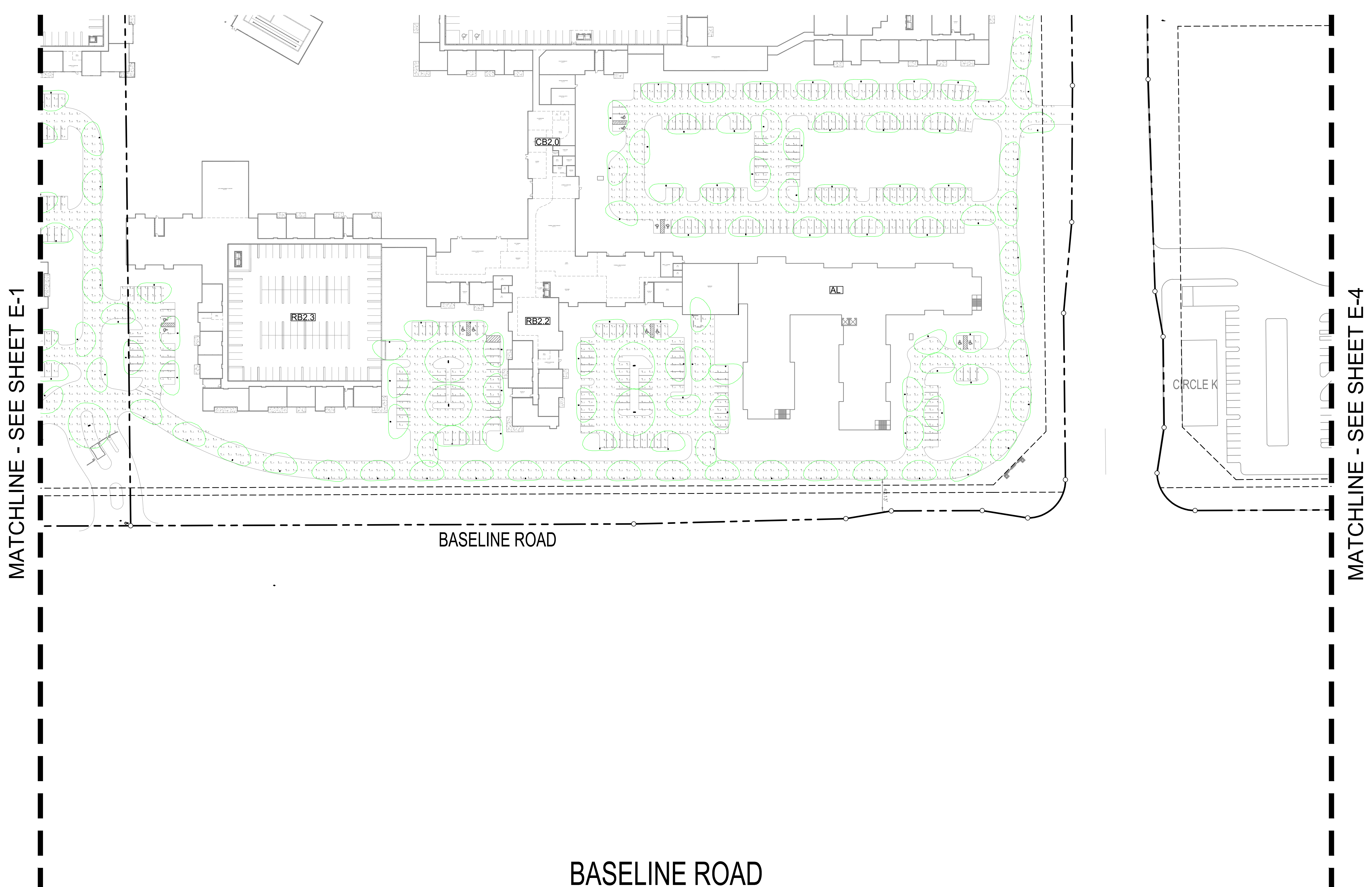

BASELINE ROAD

Calculation Summary							
Label	CalcType	Units	Avg	Max	Min	Avg/Min	Max/Min
Park n Ride	Illuminance	Fc	1.44	2.5	0.7	2.06	3.57
Parking 1	Illuminance	Fc	1.37	2.8	0.7	1.96	4.00
Parking 2	Illuminance	Fc	1.57	2.9	0.8	1.96	3.63
Parking 3	Illuminance	Fc	1.44	2.6	0.7	2.06	3.71
Parking 4	Illuminance	Fc	1.68	3.0	0.7	2.40	4.29
Parking 5	Illuminance	Fc	1.47	2.8	0.7	2.10	4.00
Parking 6	Illuminance	Fc	1.42	2.6	0.7	2.03	3.71
Parking 7	Illuminance	Fc	1.52	2.8	0.7	2.17	4.00
Parking 8	Illuminance	Fc	1.56	2.9	0.7	2.23	4.14

Luminaire Schedule						
Symbol	Qty	Label	Arrangement	Description	LLF	Luminaire Lumens
	22	37W LED_D	Back-Back	KH15QC1X37U4KC	0.920	4653
	319	37W LED	Single	KH15QC1X37U4KC	0.920	4653

6000 BASELINE ROAD
ERICKSON SENIOR LIVING ROSEVILLE

PHOTOMETRIC PLAN - E-2

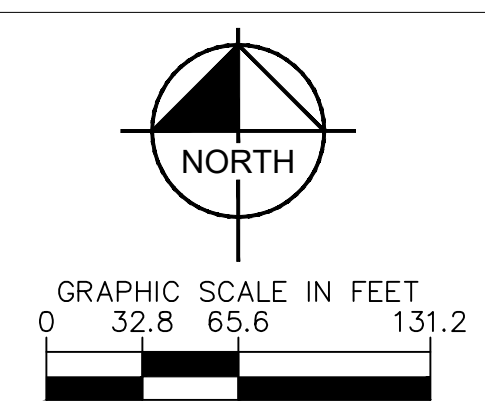

SIERRA VILLAGE DRIVE

MATCHLINE - SEE SHEET E-1

WESTBROOK BOULEVARD

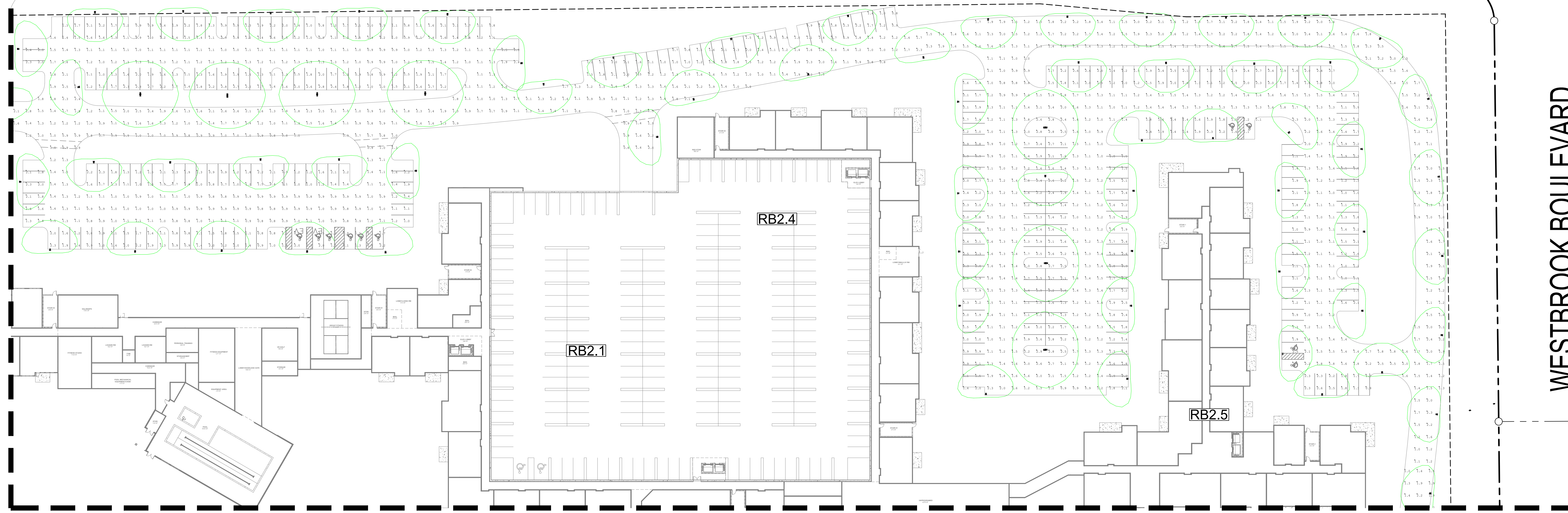

MATCHLINE - SEE SHEET E-4

Calculation Summary							
Label	CalcType	Units	Avg	Max	Min	Avg/Min	Max/Min
Park n Ride	Illuminance	Fc	1.44	2.5	0.7	2.06	3.57
Parking 1	Illuminance	Fc	1.37	2.8	0.7	1.96	4.00
Parking 2	Illuminance	Fc	1.57	2.9	0.8	1.96	3.63
Parking 3	Illuminance	Fc	1.44	2.6	0.7	2.06	3.71
Parking 4	Illuminance	Fc	1.68	3.0	0.7	2.40	4.29
Parking 5	Illuminance	Fc	1.47	2.8	0.7	2.10	4.00
Parking 6	Illuminance	Fc	1.42	2.6	0.7	2.03	3.71
Parking 7	Illuminance	Fc	1.52	2.8	0.7	2.17	4.00
Parking 8	Illuminance	Fc	1.56	2.9	0.7	2.23	4.14

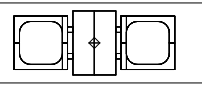
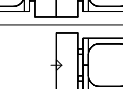
Luminaire Schedule						
Symbol	Qty	Label	Arrangement	Description	L/LF	Luminaire Lumens
	22	37W LED D	Back-Back	KH15QC1X37U4KC	0.920	4653
	319	37W LED	Single	KH15QC1X37U4KC	0.920	4653

6000 BASELINE ROAD
ERICKSON SENIOR LIVING ROSEVILLE

PHOTOMETRIC PLAN - E-3

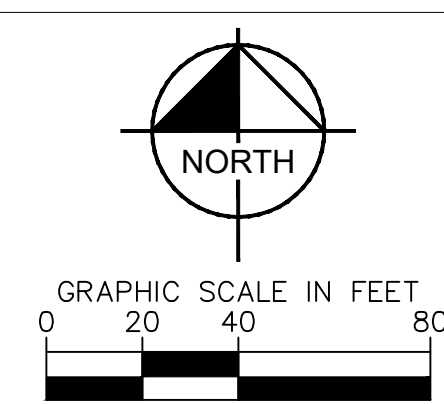

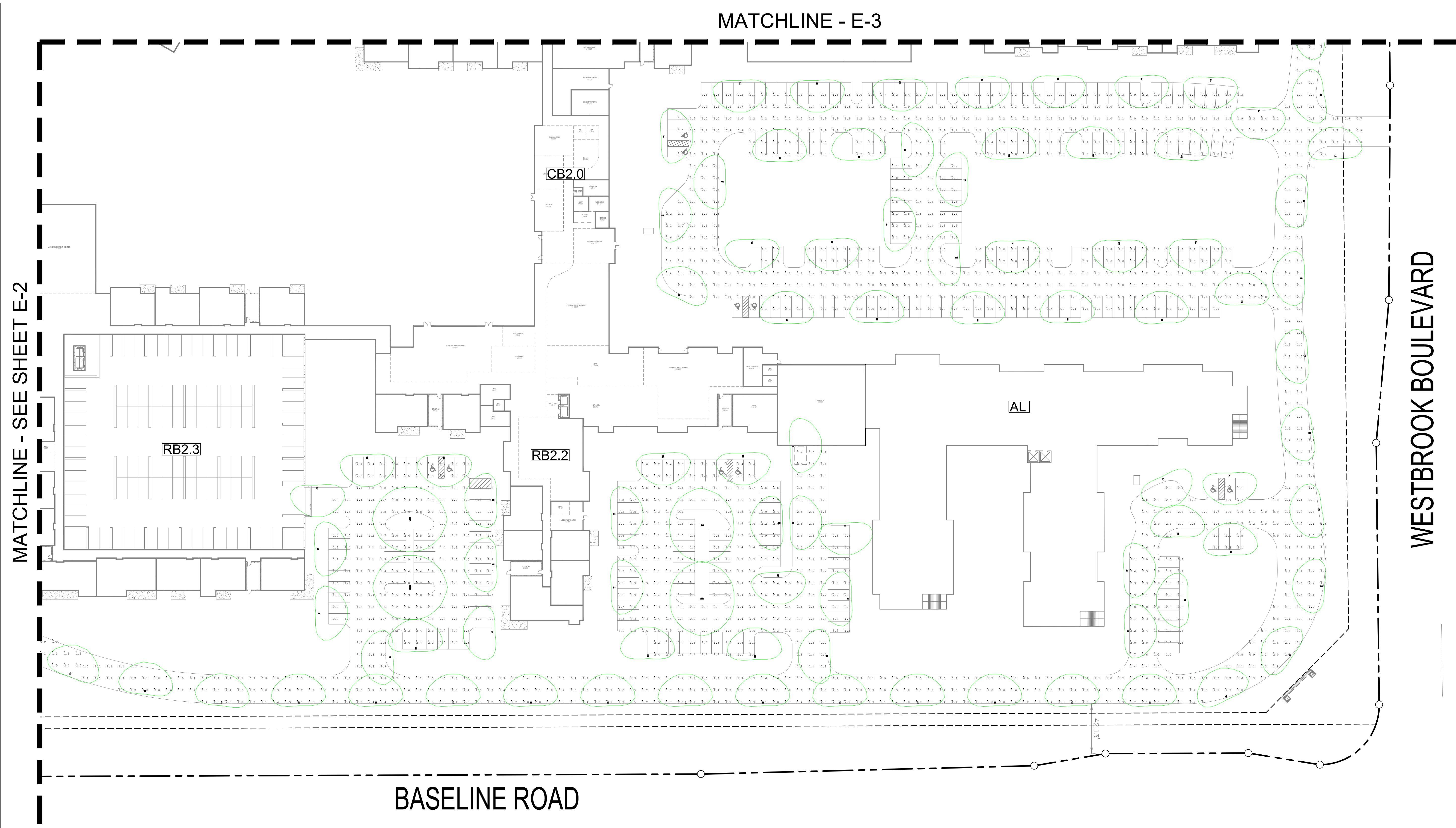

Calculation Summary							
Label	CalcType	Units	Avg	Max	Min	Avg/Min	Max/Min
Park n Ride	Illuminance	Fc	1.44	2.5	0.7	2.06	3.57
Parking 1	Illuminance	Fc	1.37	2.8	0.7	1.96	4.00
Parking 2	Illuminance	Fc	1.57	2.9	0.8	1.96	3.63
Parking 3	Illuminance	Fc	1.44	2.6	0.7	2.06	3.71
Parking 4	Illuminance	Fc	1.68	3.0	0.7	2.40	4.29
Parking 5	Illuminance	Fc	1.47	2.8	0.7	2.10	4.00
Parking 6	Illuminance	Fc	1.42	2.6	0.7	2.03	3.71
Parking 7	Illuminance	Fc	1.52	2.8	0.7	2.17	4.00
Parking 8	Illuminance	Fc	1.56	2.9	0.7	2.23	4.14

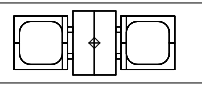
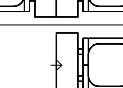
Luminaire Schedule						
Symbol	Qty	Label	Arrangement	Description	LLF	Luminaire Lumens
	22	37W LED_D	Back-Back	KH15QC1X37U4KC	0.920	4653
	319	37W LED	Single	KH15QC1X37U4KC	0.920	4653

6000 BASELINE ROAD
ERICKSON SENIOR LIVING ROSEVILLE

PHOTOMETRIC PLAN - E-4

